



BWS-T2 SERIES

Multiray safety barrier, level 2,
1 ... 2 pairs of photocells



INSTRUCTION MANUAL

WARRANTY

DATASENSOR S.p.A. warrants its products to be free from defects.

DATASENSOR S.p.A. will repair or replace, free of charge, any product found to be defective during the warranty period of 36 months from the manufacturing date.

This warranty does not cover damage or liability deriving from the improper application of DATASENSOR products.

DATASENSOR S.p.A. Via Lavino 265

40050 Monte S. Pietro - Bologna - Italy

Tel: +39 051 6765611 Fax: +39 051 6759324

<http://www.datasensor.com> e-mail: info@datasensor.com

 DATASENSOR S.p.A. cares for the environment: 100% recycled paper.

 DATASENSOR S.p.A. reserves the right to make modifications and improvements without prior notification.

826190025 Rev.F

We

DATASENSOR S.p.A.
Via Lavino, 265
40050 Monte San Pietro
Bologna - Italy

Declare, under the terms of EC Machine Directive 98/37/EEC, Appendix II C, that the product(s)

SB-BWS-T2 SAFETY CONTROLLER (TYPE 2)
WITH
S5-5-x8-xx-ST2 LIGHT BARRIER
S10-5-x8-xx-ST2 LIGHT BARRIER
S30-5-x50-xx-ST2 LIGHT BARRIER

are safety components for a machine constructed as per the EC directive 98/37/EEC. This declaration will lose its validity if any modification to devices is applied without prior consultation.

We employ a quality system certified by the CSQ, Nr. 9115.IES2, as per ISO 9001 and have therefore observed the regulations foreseen during development and production, as well as the following EC directives and EN standards:

EC directives

98/37/EEC: EC MACHINE DIRECTIVE Ed. 22 JUNE 1998
89/336/EEC: EMC DIRECTIVE Ed. 3 MAY 1989
73/23/EEC: LOW-VOLTAGE DIRECTIVE Ed. 19 FEBRUARY 1973

Harmonized standards

CEI EN 55022, JUNE 1997: LIMITS AND METHODS OF MEASUREMENTS OF RADIO DISTURBANCE OF INFORMATION TECHNOLOGY EQUIPMENT
CEI EN 61000-4-2, SEPTEMBER 1996: ELECTROMAGNETIC COMPATIBILITY (EMC). PART 4: TESTING AND MEASUREMENT TECHNIQUES. SECTION 2: ELECTROSTATIC DISCHARGE IMMUNITY TEST
CEI EN 61000-4-3, NOVEMBER 1997: ELECTROMAGNETIC COMPATIBILITY (EMC). PART 4: TESTING AND MEASUREMENT TECHNIQUES. SECTION 3: RADIATED, RADIO-FREQUENCY, ELECTROMAGNETIC FIELD IMMUNITY TEST
CEI EN 61000-4-4, SEPTEMBER 1996: ELECTROMAGNETIC COMPATIBILITY (EMC). PART 4: TESTING AND MEASUREMENT TECHNIQUES. SECTION 4: ELECTRICAL FAST TRANSIENT/BURST IMMUNITY TEST
CEI EN 61000-4-5, JUNE 1997: ELECTROMAGNETIC COMPATIBILITY (EMC). PART 4: TESTING AND MEASUREMENT TECHNIQUES. SECTION 5: SURGE IMMUNITY TEST
CEI EN 61000-4-6, NOVEMBER 1997: ELECTROMAGNETIC COMPATIBILITY (EMC). PART 4: TESTING AND MEASUREMENT TECHNIQUES. SECTION 6: IMMUNITY TO CONDUCTED DISTURBANCES, INDUCED BY RADIO-FREQUENCY FIELDS
CEI IEC 61496-2, NOVEMBER 1997: SAFETY OF MACHINERY - ELECTRO-SENSITIVE PROTECTIVE EQUIPMENT - PART 2: PARTICULAR REQUIREMENTS FOR EQUIPMENT USING ACTIVE OPTO-ELECTRONIC PROTECTIVE DEVICES (AOPDs)

Conformity has been certified by the following Competent Body:
TÜV Product Service GMBH, Zertifizierstelle – Ridlerstrasse, 65 – D80339 München

Monte San Pietro, 24/01/2002
Gianni Stradiotti

Quality Assurance Manager



INDEX

1. INTRODUCTION	page	2
1.1. Operating description	page	5
2. INSTALLATION	page	9
2.1 Mounting the BWS-T2	page	9
2.2. Start switch	page	9
2.3. Sensors	page	10
2.4. Safety distance	page	10
2.4.1. <i>Protection of danger zones with BWS-T2</i> <i>for protection of fingers and hands</i>	page	11
2.4.2. <i>Protection of access zones with BWS-T2-1-</i> <i>or more beams for arm and body protection</i>	page	12
2.5. Unwanted beam reflections	page	12
2.6. Photoelectric sensor installation	page	14
2.7. Alignment of the sensors	page	15
3. ELECTRICAL CONNECTIONS	page	16
4. TECHNICAL DATA	page	21

GENERAL VIEW

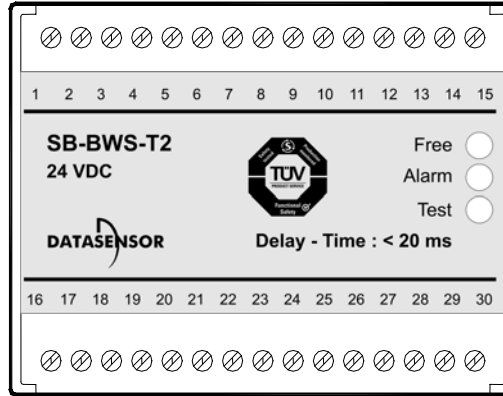

Figure A

1. INTRODUCTION

The BWS-T2 is an essential part of a photoelectric installation whose purpose is to maintain a safe environment in potentially dangerous areas where electrical machinery or equipment is in operation. It performs this task by not allowing such machinery to start up unless the dangerous area is clear of any persons or objects.

The product is designed to satisfy the following specifications (German normatives):

The BWS-T2 can be used in the below listed industrial sectors. We inform that eventually other normatives and rules of local bodies for safety at work have to be respected.

- **Cold treatment of metals**

prEN692 Mechanic presses

prEN693 Hydraulic presses

- **Machinery for plastics and rubber**

prEN201 Injection presses - moulding machinery

prEN289 Shape- and moulding presses

prEN1114 Roll- and extruding presses

prEN1417 Equipment for mixing with 2 cylinders

prEN422 Blow- shaping machinery

- **Machinery for packaging**

prEN415-2 Machinery for packaging of rigid prechaped goods

prEN415-3 Machinery for packaging, filling and enclosure

prEN415-4 Equipment for palleting and un palleting

prEN415-5 Machinery for wrapping

prEN415-6 Group packing machinery

prEN415-7 Machinery for arrangements

- **Machinery for wood treatment**
 - prEN691 General requirements
 - prEN859 Planing and straightening machinery with manual transport
 - prEN860 Single sided machinery for planing
 - prEN861 Machinery for combined planing and straightening
 - prEN1807 Band- saws
 - prEN848 Table milling machinery
 - prEN940 Combined Machinery
 - prEN1218 Double profile machinery

- **Paper- and printing machinery**
 - prEN1010 Printing machinery
 - prEN1034 Machinery for paper production

- **Machinery for tanning**
 - prEN972 Alternative machinery with movable rolls
 - prEN1035 Machinery with movable slats
 - prEN931 Machinery for scratching, grinding, polishing, folding and nailing

- **Other machinery**
 - prEN11553 Safety of Laser machinery for treating materials
 - EN775 Safety of handling automation
 - prEN1525 Driverless transport systems and their systems

Further normatives to be applied:

EN 292 Part 1: November 1991

Safety of machinery- Basic concepts, general principles for design:
Part 1: Basic terminology , methodology

EN 292 Part 2: November 1991

Safety of machinery - Basic concepts, general principles for design:
Part 2: Technical principles and specifications

EN 294: Juni 1992

Safety of machinery - Safety distances to prevent danger zones being reached by the upper limbs

EN 811: Oktober 1992

Safety of machinery - Safety distances to prevent danger zones being reached by the lower limbs

EN 999: Januar 1995

Safety of machinery - The positioning of protective equipment in respect of approach of parts of the human body

EN 954 Part 1: März 1997

Safety of machinery; Safety related parts of control systems
- General principles for design

EN 60204 Part 1 Safety of machinery, electrical equipment of machines - General requirements

Draft prEN 1050: April 1996
Safety of machinery; risk assesment

FINAL DRAFT IEC 61496-1/Ed. 1.0: Safety of machinery - electro - sensitive equipment,

Part 1: General requirements and tests.
Documents 44/206/FDIS and 44/206A/FDIS: 1997-03-28

FINAL DRAFT IEC 61496-2/Ed. 1.0: Safety of machinery - electro - sensitive equipment,

Part 2: Particular requirements for equipment using active opto-electronic protective devices.
Documents 44/208/FDIS and 44/206A/FDIS: 1997-0530

The BWS-T2 can be used in conjunction with our line of photoelectric sensors as shown in the Technical Specifications.

The BWS-T2 has been designed so that one (1) or two (2) Emitter-Receiver pairs can be connected to it.

The operating voltage is: 24VDC \pm 10%.

The status of the system is indicated by 3 visible LEDs:

- FREE green
- ALARM red
- TEST yellow

The BWS-T2 is rated as a type 2 ESPD (Electro Sensitive Protective Device) according to the EUROPEAN STANDARD.
A type 2 ESPD is a device which relies on the correct response to external tests to maintain its safety integrity. The device may not detect failures in system integrity between tests.

1.1. Operating description

The BWS-T2 features the following functions:

START INTERLOCK:

A start interlock is a means for preventing automatic starting after the BWS-T2 is switched on.

INITIAL TEST:

A test which is performed via the start switch, after the BWS-T2 has been powered, in order to test the complete safety related control system before the first operation is initiated.

RESTART INTERLOCK:

A means for preventing automatic re-starting of a machine after the optical beam(s) was (were) interrupted.

CYCLE TEST:

A test which can be performed at any time while the BWS-T2 is in the active operating mode in order to test the complete safety related control system.

The flow chart on the following page can be used to describe the operation of the BWS-T2:

BWS-T2 OPERATION

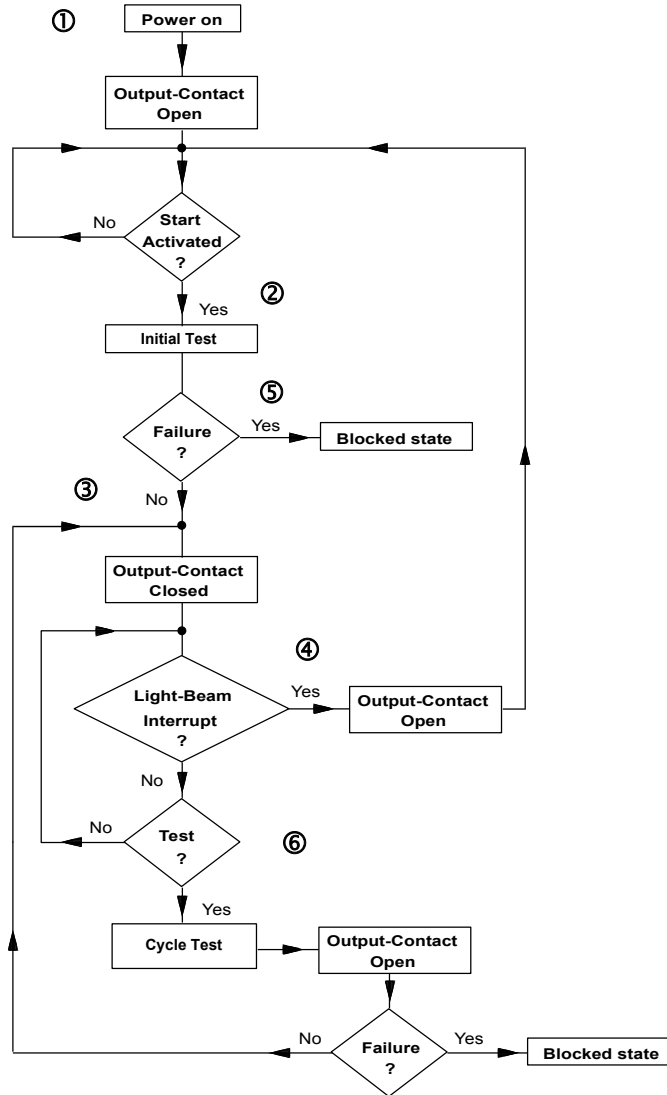

Fig. 1

- ① Upon application of power, the red ALARM LED lights up and the START INTERLOCK function will prevent the operation of the output contacts.
- ② The active operation mode can be initiated only with a N.O. (normally open) start switch. After closing the start switch, the INITIAL TEST function will be activated automatically. The red ALARM LED goes off and the yellow TEST LED lights up.
- ③ After the start switch is released, and only if no fault is detected, both N.O. output contacts will switch to the active operation mode. In this case the yellow TEST LED goes off and the green FREE LED lights up.
- ④ Thereafter, any interruption of the optical beam(s) will cause the RESTART INTERLOCK to prevent automatic re-activation and force the operator to re-initiate with the start switch.
- ⑤ If a fault is detected, after the start switch is released, the yellow TEST LED goes off and the red ALARM LED lights up; the output contacts remain open (preventing machine start up).
- ⑥ During the active operating mode, the CYCLE TEST can be performed by means of 2 N.C. contacts: Test 1 and Test 2 (see figure 2). This procedure is normally used to detect the status of the BWS-T2 periodically.

By opening the Test 1 contact, the CYCLE TEST is started; the output contacts are OPEN for the duration of the test and will CLOSE after the test is completed only if the BWS-T2 has detected no fault. The test is completed when the Test 2 contact is opened and then closed.

The CYCLE TEST is such that any short-circuit, open, or component malfunction will be instantly recognized.

The LED indicators for the CYCLE TEST have the same function as in the INITIAL TEST.

There are two ways to connect the Test 1 and Test 2 contacts:

- a) CYCLE TEST procedure using 2 N.C. contacts.

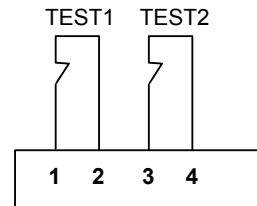

Fig. 2

When the Test 1 contact opens, the test procedure begins.

When the Test 2 contact opens and closes again, the test procedure ends.

This type of connection allows to detect short-circuits at the test cables.

- b) CYCLE TEST procedure using 1 N.C. contact.

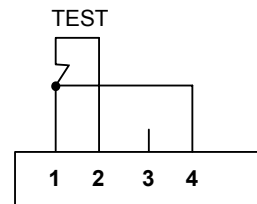

Fig. 3

When the Test contact opens, the test procedure begins; when it closes, the test procedure ends.

2. INSTALLATION

2.1. MOUNTING THE BWS-T2

The BWS-T2 must be mounted in an enclosure with at least an IP54 rating. The dimensions of the BWS-T2 are given in the following diagram for mounting purposes:

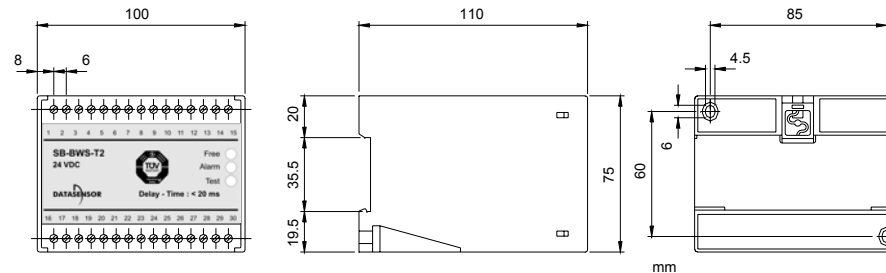

Fig. 4

2.2. START SWITCH

The external start switch, which allows the enabling of the active operating mode, must be installed in such a way that an unobstructed view of the danger area is provided.

**IT MUST NOT BE POSSIBLE TO ACTIVATE
THE START SWITCH FROM INSIDE THE DANGER AREA !**

By-passing the start switch in order to eliminate the START INTERLOCK and the RESTART INTERLOCK functions is not allowed. Therefore the start switch must be closed and then opened again to begin the INITIAL TEST.

2.3. SENSORS

The photoelectric sensors must be mounted in front of the danger area (as per EN 999) so as to protect the entire danger area.

The sensors must be installed in the vicinity of the operating equipment in such a way as to allow ENTRY or OPERATION of the machine ONLY THROUGH the safety barrier. The possibility of reaching the danger area from below, above or from around the safety barrier must be prevented. It must not be possible to move or alter the installation in any way.

In addition, it must not be possible to be inside of the danger area behind the safety barrier. This must be detected by the safety barrier.

The electrical connection from the BWS-T2 box to the sensors is done via shielded cables. The possible lengths are listed in the sensor datasheets. If using sensors with connectors, be sure that your cable is shielded.

2.4. SAFETY DISTANCE (SD)

The photoelectric sensors must be mounted at a "safety distance" (S) in front of the machine or danger area. It must be assured that the dangerous movement is stopped before a person is able to touch the dangerous moving parts.

This safety distance (S) depends upon the reaction time of the BWS-T2, the speed of the person or object penetrating the "guarded" area (approx. value: $v=1.6\text{m/s}$) and the lagtime of the machine.

See figure 5.

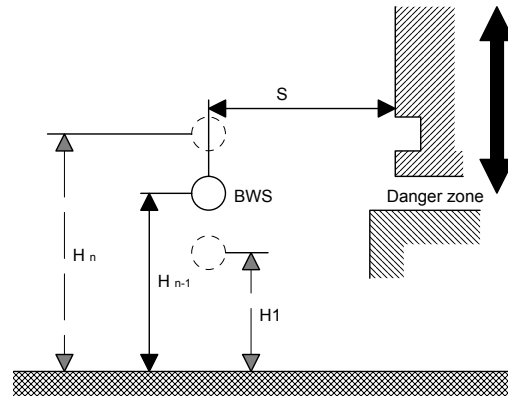

Fig. 5

$$S = V * T + C \quad C=8 (d-14\text{mm})$$

- S: Minimum distance - safety distance
- V: Approaching speed
- T: Delay time of the complete system
- C: Supposed length of a part of a body with $\varnothing <$ resolution of fotocell array, that exceeds the protecting area without a guaranteed detection.
- d: Detection capability (see table characteristics of photocells) -
Fingerresolution: $\varnothing \leq 14\text{mm}$; handresolution: $\varnothing \leq 40\text{mm}$;
armresolution: $\varnothing \leq 70\text{mm}$.
- H: Vertical position of the protecting area above the floor

2.4.1. Protection of danger zones with BWS-T2 for protection of fingers and hands

Condition: $14\text{mm} < d \leq 40\text{mm}$; $C \geq 0$

For $100\text{mm} < S \leq 500\text{mm}$ is valid:

$$S = 2000 * T + C$$

For $S \leq 500\text{mm}$ is valid:

$$S = 1600 * T + C$$

Must not be applied if also children have to be protected!

2.4.2. Protection of access with BWS-T2-1- or more beams for arm and body protection

Condition: $40\text{mm} < d \leq 70\text{mm}$; $C \leq 0$
 $S = 1600 * T + 850\text{mm}$

Mounting height of the emitter(s) and receiver(s):

1 Pair E/R:	750mm		
2 Pairs E/R:	400mm, 900mm		
3 Pairs E/R:	300mm, 700mm,	1100mm	
4 Pairs E/R:	300mm, 600mm,	900mm,	1200mm

Criterion: No limbs passing below the lowest beam
 No limbs passing below the highest beam
 No limbs passing between 2 beams
 No passage between 2 beams
 Highest beam $\leq 900\text{mm}$, lowest beam $\leq 300\text{mm}$

2.5. UNWANTED BEAM REFLECTIONS

Specular reflections from shiny surfaces in proximity or within the beam envelope (cone) can reflect light, thus affecting the ability to detect an intrusion into the guarded area.

The minimum distances shown in figures 7a and 7b must be respected to satisfy the arrangement shown in figure 6b (figure 6a is not correct).

INCORRECT
INSTALLATION

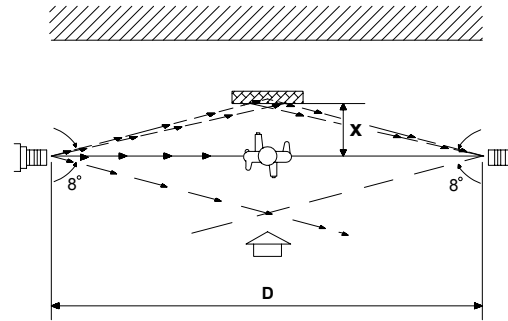

Fig. 6a

CORRECT
INSTALLATION

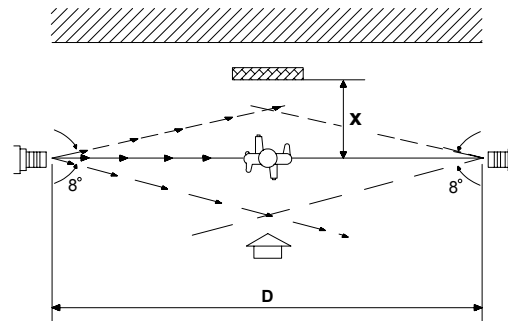

Fig. 6b

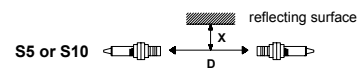
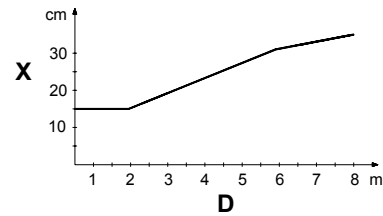

Fig. 7a

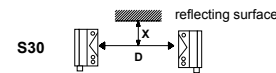
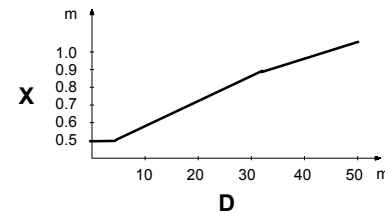

Fig. 7b

2.6. PHOTOELECTRIC SENSOR INSTALLATION

When mounting the sensors (emitter **E**/receiver **R** pairs) to the BWS-T2, care must be taken to position these components in such a way as not to interfere with each other. (including with the help of a mirror, see figure 8b and 8c). The layouts in figures 8a-8d are bad examples NOT to follow because they are unreliable.

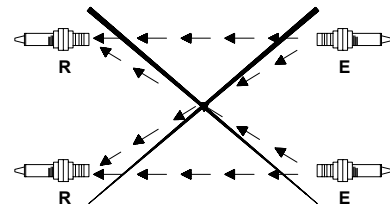

Fig. 8a

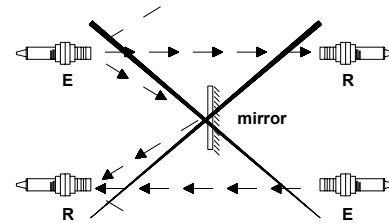

Fig. 8b

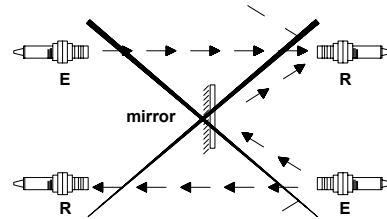

Fig. 8c

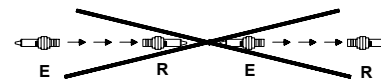

Fig. 8d

Figures 9a-9b show the proper disposition of these elements.

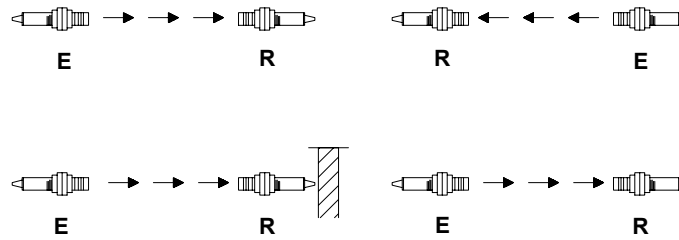

Fig. 9a

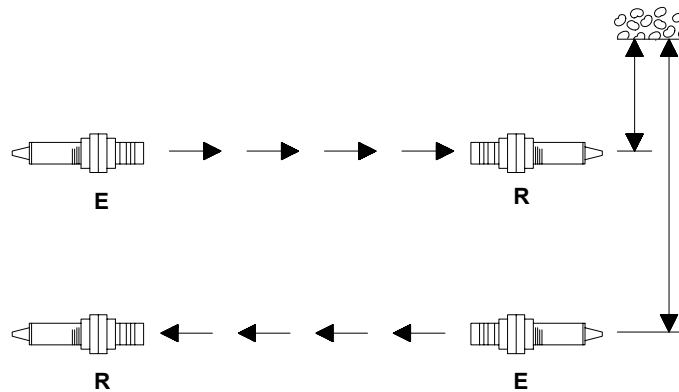

Fig. 9b

2.7. ALIGNMENT OF THE SENSOR(S)

To align the sensor(s), you have to bridge the start switch from terminal 19 to terminal 20. Using the Receiver output LED of the photoelectric sensor(s) you can align the light barrier.

If the sensors are correctly positioned, the yellow TEST LED lights up. If beam 1 or 2 is interrupted, the ALARM LED at the BWS-T2 lights up and the TEST LED turns off.

When the alignment is completed, disconnect the bridge between Terminal 19 and Terminal 20.

3. ELECTRICAL CONNECTIONS

The BWS-T2 controller provides for the following connections:

Signal	Terminal
Output 1	14; 29
Output 2	15; 30
Start	19; 20
Test 1	1;2
Test 2	3;4
Emitter 1	5;6;7;8
Receiver 1	21;22;23;24
Emitter 2	25;26;27;28
Receiver 2	9;10;11;12
Input +24 VDC	16
GND	18
Earth GND	17

See the individual diagrams (figures 10 - 13) for wiring details.

CAUTION

Supply only the photocells from this device!
Always use shielded cables to wire the emitter and receiver pairs.

One (1) or two (2) emitter-receiver pair(s) can be connected to the BWS-T2. If using only one Emitter-Receiver pair, the cables of the Emitter must be connected to the EMITTER 1 terminals and the cables of the Receiver must be connected to the RECEIVER 2 terminals. The EMITTER 2 and RECEIVER 1 terminals remain free.

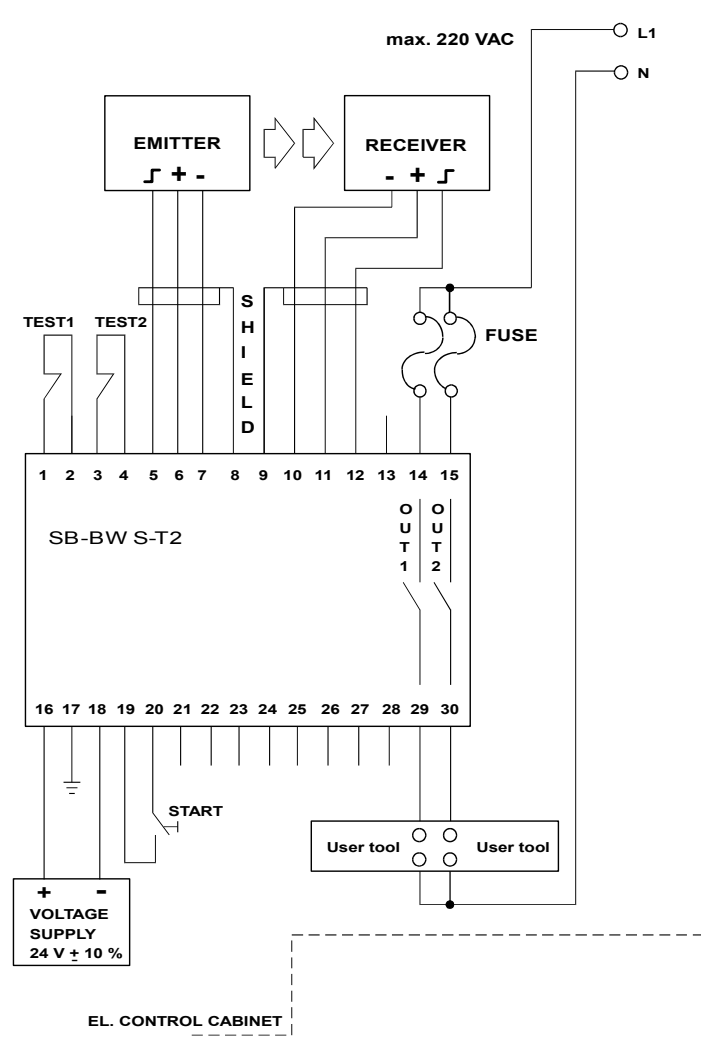

Fig.10 - One Emitter/Receiver pair

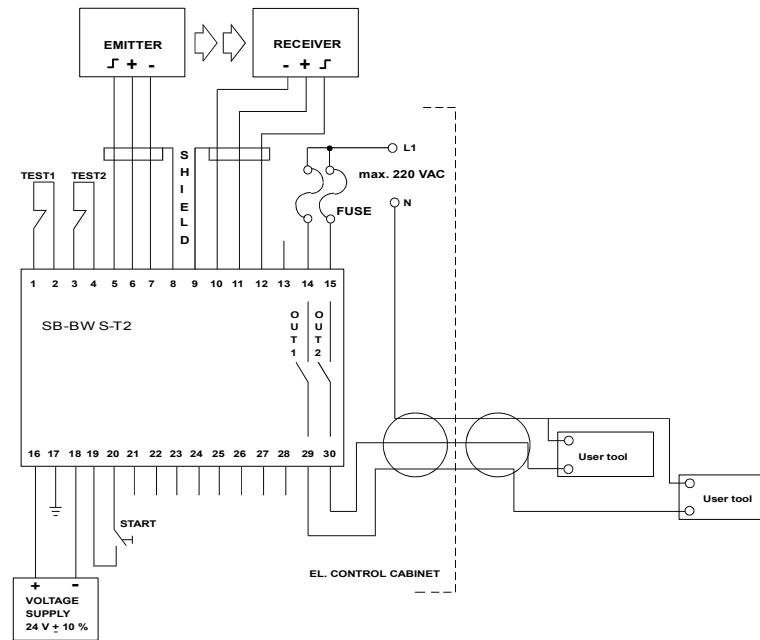

Fig. 11 - One Emitter/Receiver pair

NOTE

Be sure that L1 is switched by the 2 output contacts and not N.

If only one User Tool is used, the output contacts can be tied together.

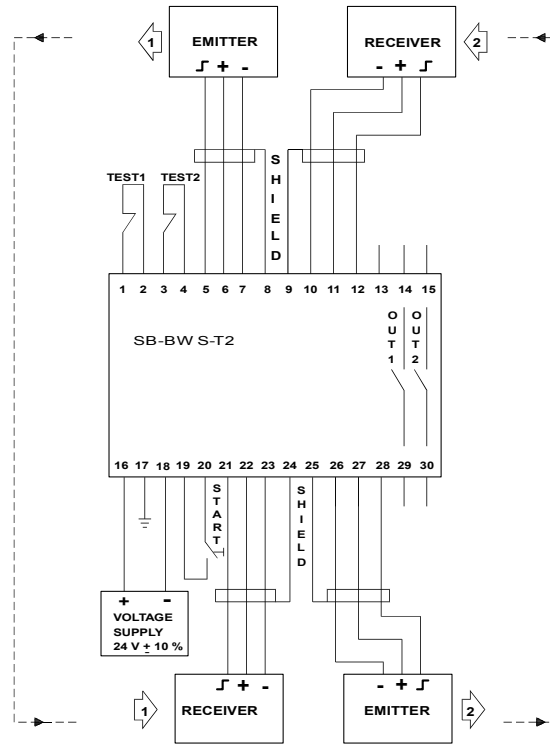

Fig. 12 - Two Emitter/Receiver pairs

When operating with 2 E-R pairs, the wiring configuration shown in figure 12 must be respected. It must be made certain, that EMITTER 1 directs its beam only to RECEIVER 1 and EMITTER 2 directs its beam only to RECEIVER 2.

CAUTION

Make sure that EMITTER 1 never directs to RECEIVER 2. To satisfy this demand, verify that the BWS-T2 switches from GREEN to RED status, when beam one OR beam two are interrupted separately.

The maximum specified rating of the BWS-T2 output contacts must not be exceeded.

With inductive loads, arc suppression or switching as described below should be utilized. For user tools that require load currents that exceed the BWS-T2 contact rating, auxiliary power operated switches must be used (see figure 13).

The N.O. contacts of the auxiliary power operated switches H1/H2 are used to wire directly to the machine control itself. The N.C. contacts of H1/H2 insure that in case of a defective switch the machine will not restart.

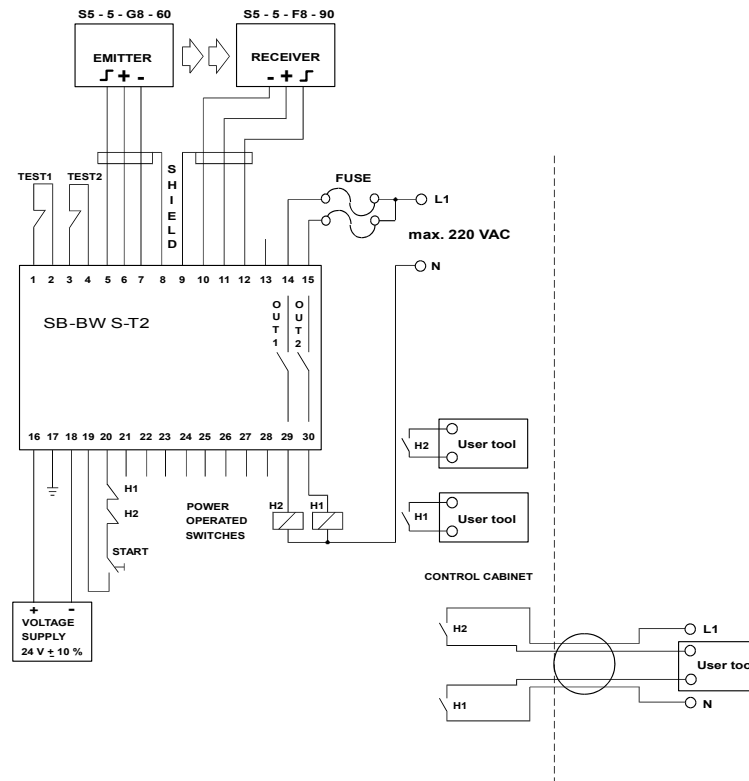

Fig. 13 - If load current exceeds I_{max}

4. TECHNICAL DATA

Voltage:	24 Vdc \pm 10%, reverse polarity protection
Max Power Consumption: (1 Emitter-Receiver pair) (2 Emitter-Receiver pair)	3.4 W 3.8 W
Weight:	510 g. (without sensors)
Operating Temperature:	0...50 °C
Output: (SDS safety relay) V max 220 V AC I_{max} 220 V AC 30 V DC	4 A AC (load life 100000 ops) 2 A AC (load life 500000 ops) 2 A DC
Fuse Rating:	60% of I_{max}
Input Signals: Start: N.O. contact One-way wire length: Test 1/2: N.C. One way wire length:	contact close time > 40 ms < 10 m contact open time > 40 ms < 10 m
Reaction Time:	< 20 ms
Initial Test Time:	150 ms + contact close time
Cycle Test Time:	150 ms + test contact time
Sensing Distance and Background Suppression:	Depends on type of Emitter-Receiver used
Enclosure Protection:	IP20 when mounted in control enclosure with at least a IP54 rating

Specifications related to the photoelectric sensors

Type	S5	S10	S30
Emitter	S5-5-G8-60-ST2 S5-5-G8-62-ST2	S10-5-G8-60-ST2 S10-5-G8-62-ST2	S30-5-G50-1-ST2 S30-5-G50-2-ST2
Receiver (Light pulse PNP output)	S5-5-F8-90-ST2 S5-5-F8-92-ST2	S10-5-F8-90-ST2 S10-5-F8-92-ST2	S30-5-F50-1-ST2 S30-5-F50-2P-ST2 select light pulse!
Max. sensing distance	8 m		50 m
Min. object class	∅ 15 mm		∅ 20 mm
Protection class	IP67		
Length of the shielded cable	30m		