

User's Manual

LG Programmable Logic Controller

GLOFA G6F – AD2A

LG Industrial Systems

© CONTENTS ©

Chapter 1. INTRODUCTION

1.1 Features	1-1
1.2 Glossary	1-1
1.2.1 A-Analog Value	1-1
1.2.2 D-Digital Value	1-1
1.2.3 Analog / Digital Conversion Characteristics	1-2

Chapter 2. SPECIFICATIONS

2.1 General Specifications	2-1
2.2 Performance Specifications	2-2
2.3 Names of Parts and Functions	2-3
2.4 I/O Conversion Characteristics	2-4
2.4.1 Voltage Input Characteristics	2-4
2.4.2 Current Input Characteristics	2-5
2.4.3 Simultaneous Voltage and Current Input Characteristics	2-5
2.4.4 Analog Input and Digital output Characteristics	2-6
2.5 Averaging Process	2-6

Chapter 3. INSTALLATION AND WIRING

3.1 Installation	3-1
3.1.1 Installation Ambience	3-1
3.1.2 Handling Precautions	3-1
3.2 Wiring	3-2
3.2.1 Wiring Precautions	3-2
3.2.2 Wiring Examples	3-2

Chapter 4. FUNCTION BLOCK

4.1	Insertion of the Function Block for the A/D Conversion Module on the GMWIN	4-1
4.2	Local Function Block	4-2
4.2.1	Module Initialization (AD2INI)	4-2
4.2.2	Module Reading - Array Type (AD2ARD)	4-3
4.2.3	Module Reading - Single Type (AD2RD)	4-3
4.3	Errors on Function Block	4-4

Chapter 5. PROGRAMMING

5.1	Programming for Distinction of A/D Conversion Value	5-1
5.2	Programming for Display of A/D Conversion Value and Error Code on BCD Display...	5-5

Chapter 6. DIMENSIONS

6.1	G6F-AD2A	6-1
------------	-----------------	------------



SAFETY PRECAUTIONS

Be sure to read carefully the safety precautions given in data sheet and user's manual before operating the module and follow them.

The precautions explained here only apply to the G6F-AD2A

For safety precautions on the PLC system, see the GLOFA GM6 User's Manuals.

A precaution is given with a hazard alert triangular symbol to call your attention, and precautions are represented as follows according to the degree of hazard.

 WARNING	⇒	If not provided with proper prevention, it can cause death or fatal injury or considerable loss of property.
 CAUTION	⇒	If not properly observed, it can cause a hazard situation to result in severe or slight injury or a loss of property.

However, a precaution followed with  **CAUTION** can also result in serious conditions.

Both of two symbols indicate that an important content is mentioned, therefore, be sure to observe it.

Keep this manual handy for your quick reference in necessary.

Design Precautions

 **CAUTION**

- ▶ Do not run I/O signal lines near to high voltage line or power line. Separate them as 100 mm or more as possible. Otherwise, noise can cause module malfunction.

Installation Precautions

 **CAUTION**

- ▶ Operate the PLC in the environment conditions given in the general specifications.
- ▶ If operated in other environment not specified in the general specifications, it can cause an electric shock, a fire, malfunction or damage or degradation of the module
- ▶ Make sure the module fixing projections is inserted into the module fixing hole and fixed.
- ▶ Improper installation of the module can cause malfunction, disorder or falling.

Wiring Precautions



CAUTION

- ▶ When grounding a FG terminal, be sure to provide class 3 grounding which is dedicated to the PLC.
- ▶ Before the PLC wiring, be sure to check the rated voltage and terminal arrangement for the module and observe them correctly.
If a different power, not of the rated voltage, is applied or wrong wiring is provided, it can cause a fire or disorder of the module.
- ▶ Drive the terminal screws firmly to the defined torque.
If loosely driven, it can cause short circuit, a fire or malfunction.
- ▶ Be careful that any foreign matter like wire scraps should not enter into the module.
It can cause a fire, disorder or malfunction.

Test Run and Maintenance Precautions



WARNING

- ▶ Do not contact the terminals while the power is applied.
It can cause malfunction.
- ▶ When cleaning or driving a terminal screw, perform them after the power has been turned off
- ▶ Do not perform works while the power is applied, which can cause disorder or malfunction.



CAUTION

- ▶ Do not separate the module from the printed circuit board(PCB), or do not remodel the module.
They can cause disorder, malfunction, damage of the module or a fire.
When mounting or dismounting the module, perform them after the power has been turned off.
- ▶ Do not perform works while the power is applied, which can cause disorder or malfunction.

Waste Disposal Precautions



CAUTION

- ▶ When disposing the module, do it as an industrial waste.

Chapter 1. INTRODUCTION

The G6F-AD2A is analog/digital conversion modules for use with the GLOFA PLC GM 6 series CPU module.
 The G6F-AD2A is used on GM6 series module. (Hereafter the G6F-AD2A is called the A/D conversion module)
 The A/D conversion module is to convert an analog input signal (voltage or current) from external device into a 16-bit signed BIN (Binary) digital value.

1.1 Features

- 1) 4 channels analog to digital conversion is possible with a single module.
 The G6F-AD2A has 4 channels of A/D conversion with each channel selectable for voltage or current input.
- 2) The number of the analog module including G6F-AD2A, G6F-DA2V and G6F-DA2I used on a base unit is limitless. But the number of analog module is limited by the $\pm 15\text{VDC}$ capacity of the power supply module (GM6-PAFB)

1.2 Glossary

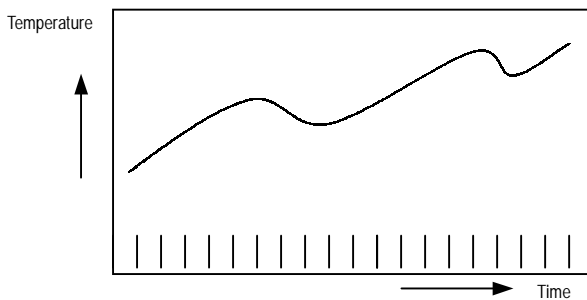

[Fig 1.1] Analog Value

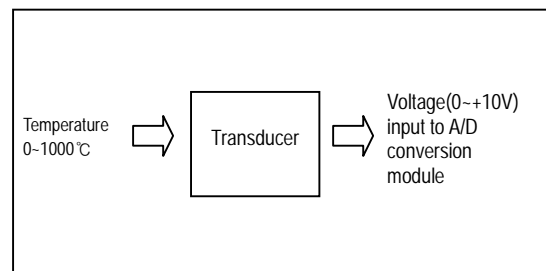

[Fig 1.2] Transducer

1.2.1 A-Analog Value

Analog value is a sequentially changing value such as voltage, current, temperature, speed, pressure, flux, etc. Temperature, for example, is sequentially changing according to the time. Because this temperature is not inputted to the PLC, the analog value of DC voltage (0 to +10 V) or current (4 to 20 mA) in accordance with the temperature should be inputted to the PLC through transducer.

1.2.2 D-Digital Value

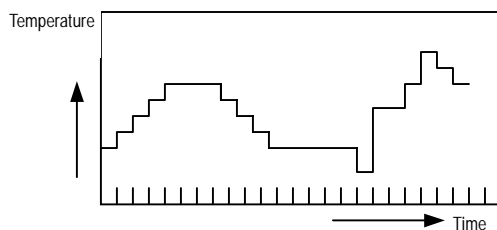

[Fig 1.3] Digital Value

Digital value is non-sequentially changing value written as the number like 0, 1, 2, 3. The signal of on or off is written as digital value of 0 or 1. There are BCD value and binary value in the range of digital value.

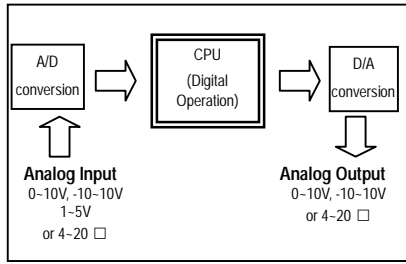

[Fig 1.4] PLC Processing

Analog value can not be written directly to the CPU. For analog input to the CPU operation, analog data converted to digital value has to be inputted to the CPU and the digital value of the CPU should be converted to analog value for analog output.

1.2.3 Analog/Digital Conversion Characteristics

1) Voltage input

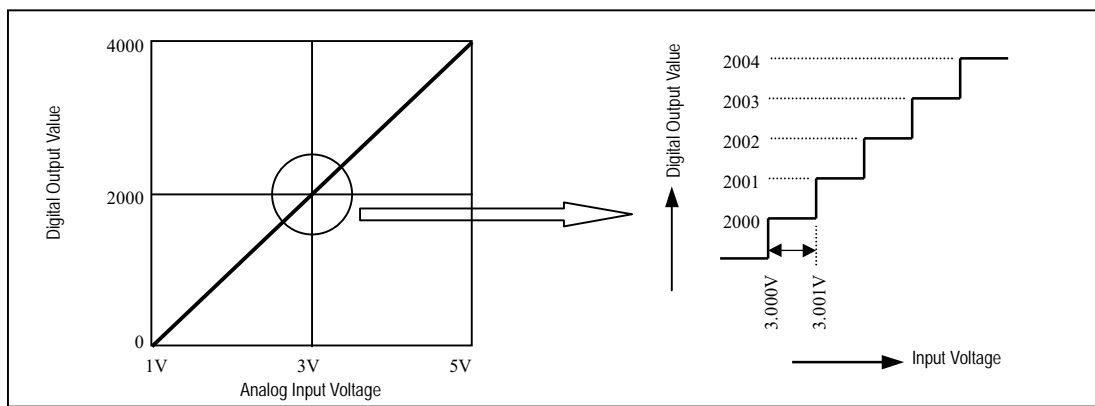

[Fig 1.5] A/D Conversion Characteristics (Voltage Input)

Analog/digital conversion module allows external analog input to be converted to digital value and to be processed in the CPU. On voltage input, input of 1V leads to digital value of 0 and 5V to 4000 as digital value. Input of 1mV is equal to digital value of 1. Therefore, input less than 1mV shouldn't be converted.

2) Current input

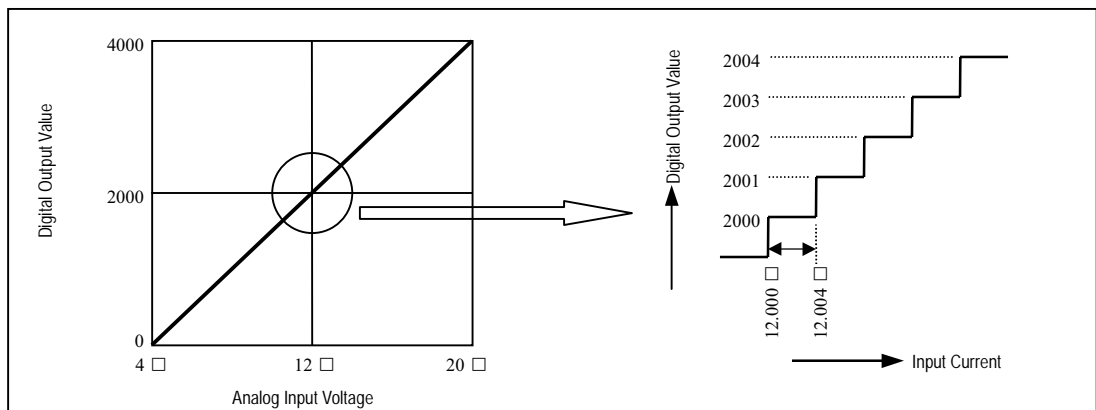

[Fig 1.6] A/D Conversion Characteristics (Current input)

On current input, input of 4mA leads to digital value of 0, 12mA to 2000 and 20mA to 4000. Input of 4μA is equal to digital value of 1. Therefore, input less than 4μA can't be converted.

Chapter 2 . SPECIFICATIONS

2.1 General Specifications

Table 2.1 shows the general specifications of GLOFA GM series.

Item	Specifications				Standard	
Operating ambient temperature	0 ~ 55 °C					
Storage ambient temperature	-25 ~ 70 °C					
Operating ambient humidity	5 ~ 95%RH, non-condensing					
Storage ambient humidity	5 ~ 95%RH, non-condensing					
Vibration	In case of occasional vibration			Sweep count 10 times in each direction for X, Y, Z	IEC 1131-2	
	Frequency	Acceleration	Amplitude			
	10 ≤ f < 57 Hz	-	0.075 mm			
	57 ≤ f ≤ 150 Hz	9.8m/s ² (1G)	-			
	In case of continuous vibration					
	Frequency	Acceleration	Amplitude			
	10 ≤ f < 57 Hz	-	0.035 mm			
	57 ≤ f ≤ 150 Hz	4.9m/s ² (0.5G)	-			
Shocks	*Maximum shock acceleration: 147m/s ² {15G} *Duration time :11 ms *Pulse wave: half sine wave pulse(3 times in each of X, Y and Z directions)				IEC 1131-2	
Noise immunity	Square wave impulse noise	± 1,500 V			LGIS Standard	
	Electrostatic discharge	Voltage :4kV(contact discharge)			IEC 1131-2 IEC 801-2	
	Radiated electromagnetic field	27 ~ 500 MHz, 10 V/m			IEC 1131-2 IEC 801-3	
	Fast transient & burst noise	Modules	All power modules	Digital I/Os (Ue ≥ 24 V)	Digital I/Os (Ue < 24 V) Analog I/Os communication I/Os	IEC 1131-2 IEC 801-4
		Voltage	2 kV	1 kV	0.25 kV	
Operating atmosphere	Free from corrosive gases and excessive dust					
Altitude for use	Up to 2,000m					
Pollution degree	2 or lower					
Cooling method	Self-cooling					

[Table 2.1] General specifications

REMARK

- 1) IEC(International Electrotechnical Commission)
 - : The international civilian organization which produces standards for electrical and electronics industry.
- 2) Pollution degree
 - : It indicates a standard of operating ambient pollution level.
 - The pollution degree 2 means the condition in which normally, only non-conductive pollution occurs.
 - Occasionally, however, a temporary conductivity caused by condensation shall be expected.

2.2 Performance Specifications

Table 2-2 shows performance specifications of A/D conversion module.

Items		Specifications
Analog input	Voltage	1 ~ 5 VDC (input resistance 1MΩ) 0 ~ 10 VDC (input resistance 1MΩ) -10 ~ 10VDC (input resistance 1MΩ)
	Current	DC4 ~ 20 mA (input resistance 250Ω)
	Voltage/Current selection	- Selection with Terminal (It has to be connected between V and I terminal to select current.) - Selection of voltage range by switch on the side of module
Digital output		- 12 bit binary value(-48 ~ 4047, -2048 ~ 2047) - Digital output value is selected by program.
Maximum resolution	1 ~ 5VDC	1 mV (1/4000)
	0 ~ 10VDC	2.5 mV (1/4000)
	-10 ~ 10VDC	5 mV (1/4000)
	DC 4 ~ 20mA	4μA (1/4000)
Overall Accuracy		± 0.5% (accuracy to full scale)
Max. conversion speed		5.0 ms/channel
Max. absolute input		Voltage : 15V, Current : 25mA
Number of analog input point		4 channels/module
Isolation		Between input terminals and PLC: Photo coupler isolation (Between channels : Non-isolated)
Terminals connected		18-point terminal block
Current Consumption	+5VDC	40mA
	+15VDC	50mA
	-15VDC	20mA
Weight		200g

[Table 2.2] Performance Specifications



CAUTION

The factory-set value of A/D conversion module has been current input mode.

2.3 Names of Parts and Functions

The names of parts and functions of the A/D conversion module are shown as below.

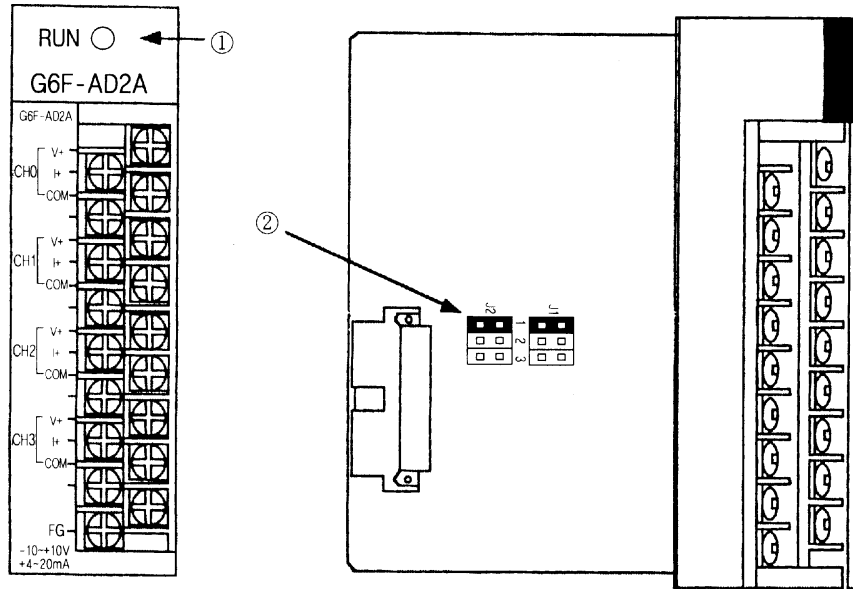

No	Description														
①	RUN LED	Indicates the operating status of the G6F-AD2A.													
②	Selection switch of voltage/current	<table border="1"> <thead> <tr> <th></th> <th>Analog Input</th> <th>Input Range Selection Switch</th> </tr> </thead> <tbody> <tr> <td rowspan="3">Voltage</td> <td>DC 1~5V</td> <td> J1: </td> </tr> <tr> <td>DC 0~10V</td> <td> J1: </td> </tr> <tr> <td>DC-10~10V</td> <td> J1: </td> </tr> <tr> <td>Current</td> <td>DC 4~20mA</td> <td> J1: </td> </tr> </tbody> </table>		Analog Input	Input Range Selection Switch	Voltage	DC 1~5V	J1:	DC 0~10V	J1:	DC-10~10V	J1:	Current	DC 4~20mA	J1:
	Analog Input	Input Range Selection Switch													
Voltage	DC 1~5V	J1:													
	DC 0~10V	J1:													
	DC-10~10V	J1:													
Current	DC 4~20mA	J1:													

2.4 I/O Conversion Characteristics

Input / Output (hereafter I/O) conversion characteristics is expressed with the angle of the line between analog input(voltage and current) and matched digital value.

The voltage or current input for a channel is selected by analog input selection switch and the value of Offset / Gain can not be changed because it is fixed.

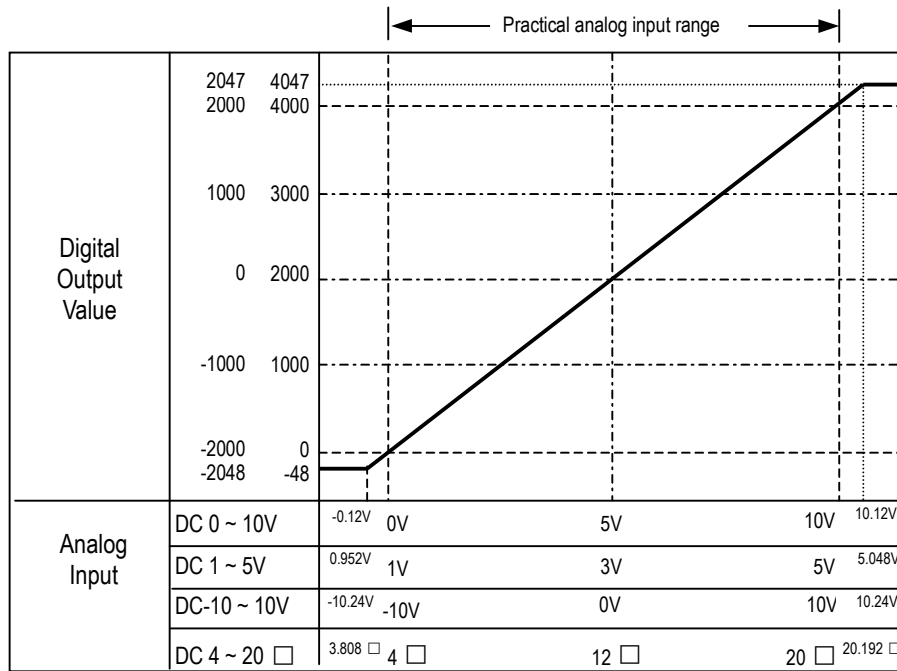

[Fig 2.1] I/O Conversion Characteristics

REMARK



1. The analog output value of over 4047 or -48 is fixed as 4047 or -48.
2. Keep the input voltage and current not to exceed +15V and 25mA.

2.4.1 Voltage Input Characteristics

For voltage input, the corresponding input is selected by selection switch and selected input voltage range is same through whole channels.

1) Voltage input range : DC 1 ~5V

Digital output value for input voltage is shown as follows.

	Analog input voltage (V)							Input range selection switch
	0.952	1	2	3	4	5	5.048	
Digital output value	-48	0	1000	2000	3000	4000	4047	J1  J2 
	-2048	-2000	-1000	0	1000	2000	2047	

2) Voltage input range : DC 0 ~ 10V

Digital output value for input voltage is shown as follows.

	Analog input voltage (V)							Input range selection switch
	-0.12	0	2.5	5	7.5	10	10.12	
Digital output value	-48	0	1000	2000	3000	4000	4047	
	-2048	-2000	-1000	0	1000	2000	2047	

3) Voltage input range : DC -10 ~ 10V

Digital output value for input voltage is shown as follows.

	Analog input voltage (V)							Input range selection switch
	-10.24	-10	-5	0	5	10	10.24	
Digital output value	-48	0	1000	2000	3000	4000	4047	
	-2048	-2000	-1000	0	1000	2000	2047	

2.4.2 Current Input Characteristics

Digital output value for input voltage is shown as follows.

	Analog input current (mA)							Input range selection switch
	3.808	4	8	12	16	20	20.192	
Digital output value	-48	0	1000	2000	3000	4000	4047	
	-2048	-2000	-1000	0	1000	2000	2047	

It has to be connected between V and I terminal to select current.

2.4.3 Simultaneous Voltage and Current Input Characteristics

For simultaneous use of voltage and current input, the available input voltage range is 0 ~ 5VDC only.

Digital output value for analog input is shown as follows..

	Analog input						
Voltage DC1~ 5V	0.952	1	2	3	4	5	5.048
Current DC4 ~ 20mA	3.808	4	8	12	16	20	20.192
Digital output value	-48	0	1000	2000	3000	4000	4047
	-2048	-2000	-1000	0	1000	2000	2047

Ex) channel for voltage : 0, channel for current : 1

Input Range Selection Switch	Wiring Example	
	Voltage Input(Channel "0")	Current Input(Channel "1")

2.4.4 Analog input and Digital output characteristics

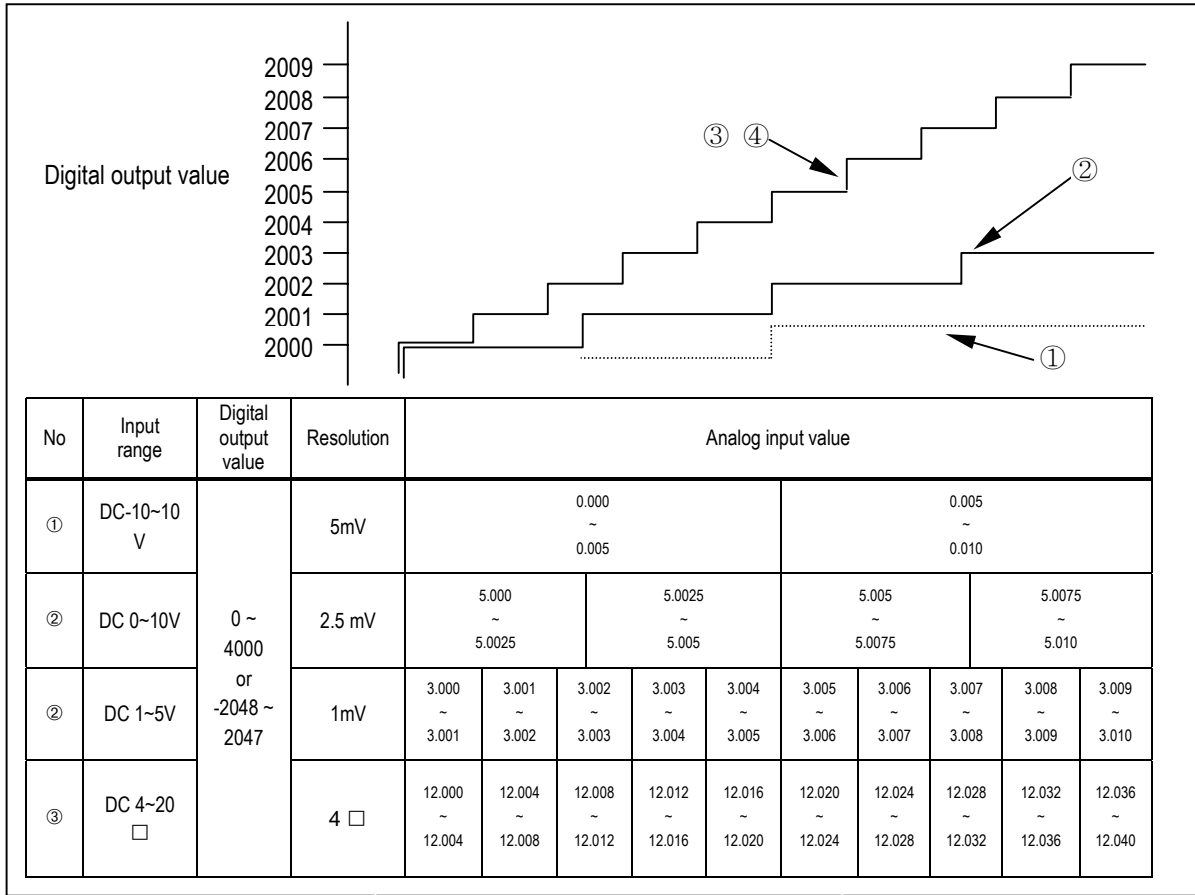

Analog input and Digital output

2.5 Averaging Process

G6F-AD2A has a average processing function of the number of times to stabilize the system control from the abnormal analog input or external noise.

- 1) Setting range : 2 ~ 255
- 2) The processing time to write averaged digital value to buffer memory is changed according to the number of channel.

$$\text{Processing time} = \text{Setting times} \times \text{Number of enabled channel} \times \text{Conversion speed}$$

Example) using channels : 4, setting times : 50

$$\text{Processing time} = 50 \times 4 \times 5 = 1000 \square$$

Chapter 3. INSTALLATION AND WIRING

3.1 Installation

3.1.1 Installation Environment

This module has high reliability regardless of its installation ambience. But be sure to check the following for system in higher reliability and stability.

1) Ambience Requirements

Avoid installing this module in locations, which are subjected or exposed to:

- Water leakage and a large amount of dust, powder and other conductive power, oil mist, salt, of organic solvent exists.
- Mechanical vibrations of impacts are transmitted directly to the module body.
- Direct sunlight.
- Dew condensation due to sudden temperature change.
- High or low temperatures (outside the range of 0-55 °C)

2) Installing and Wiring

- During wiring or other work, do not allow any wire scraps to enter into it.
- Install it on locations that are convenient for operation.
- Make sure that it is not located near high voltage equipment on the same panel.
- Make sure that the distance from the walls of duct and external equipment be 50 mm or more.
- Be sure to be grounded to locations that have good noise immunity.

3.1.2 Handling Precautions

From unpacking to installation, be sure to check the following:

- 1) Do not drop it off, and make sure that strong impacts should not be applied.
- 2) Do not dismount printed circuit boards from the case. It can cause malfunctions.
- 3) During wiring, be sure to check any foreign matter like wire scraps should not enter into the upper side of the PLC, and in the event that foreign matter entered into it, always eliminate it.
- 4) Be sure to disconnect electrical power before mounting or dismounting the module.
- 5) Install a module with guide on base and lock the module.

3.2 Wiring

3.2.1 Wiring Precautions

- 1) Separate AC and external input signal of A/D conversion module wiring not to be affected by surge or induced noise in the AC.
- 2) External wiring has to be at least AWG22(0.3mm²) and be selected in consideration of operating ambience and/or allowable current.
- 3) Separate wiring from devices and/or substances generating intense heat, and oil not to make short-circuit which leads to damage and/or mis-operation.
- 4) Identify the polarity of terminal block before external power supply is made connected.
- 5) Separate external wiring sufficiently from high voltage and power supply cable not to cause induced failure and/or malfunction.

3.2.2 Wiring Examples

1) Voltage Input

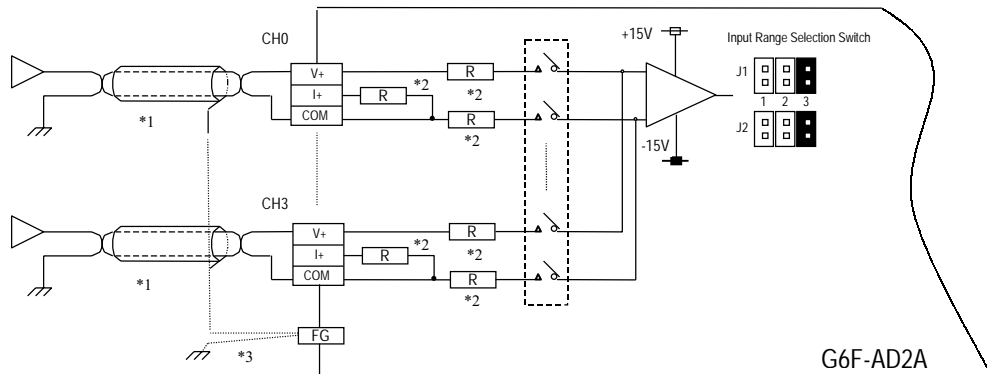

2) Current Input

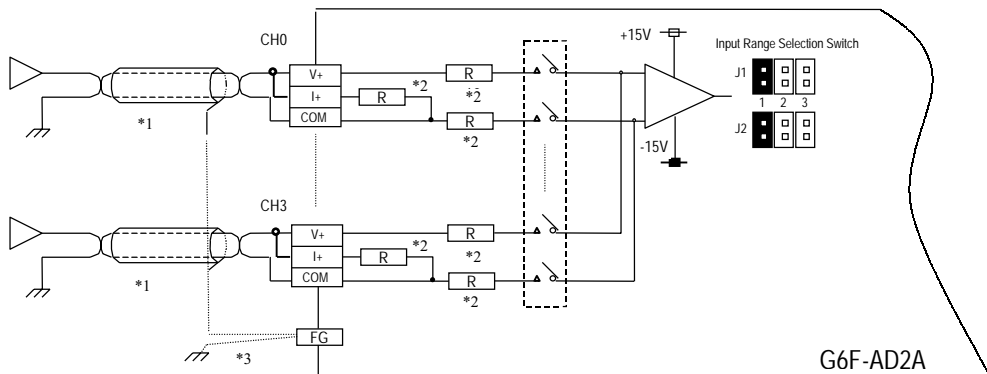

*1 For the cable, use a two-core twisted shielded wire.

*2 This is input resistor.

*3 If noise is expected, this has to be grounded.

Chapter 4. FUNCTION BLOCK

This shows function block for A/D conversion module on the GMWIN.

A kind of function block is as follows.

No	Local	Function
1	AD2INI	Initializing module
2	AD2ARD	Reading A/D converted value(Array Type)
3	AD2RD	Reading A/D converted value(Single Type)

4.1 Registration of the Function Block for A/D Conversion Module on the GMWIN

Function Block is inserted on the execution of the GMWIN according to following procedure.

Function block can be inserted only in the open condition of the Project.

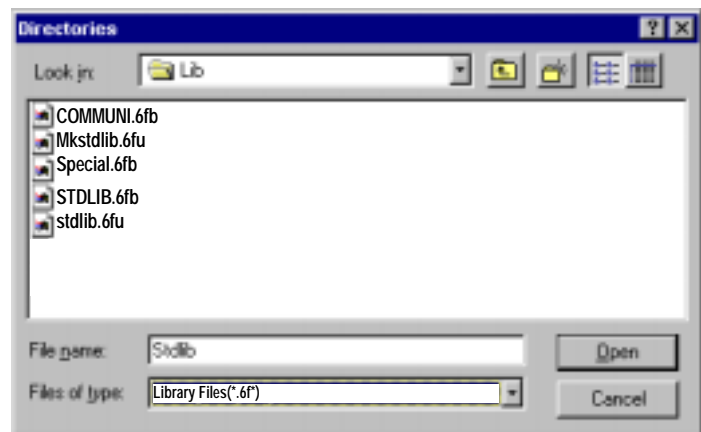
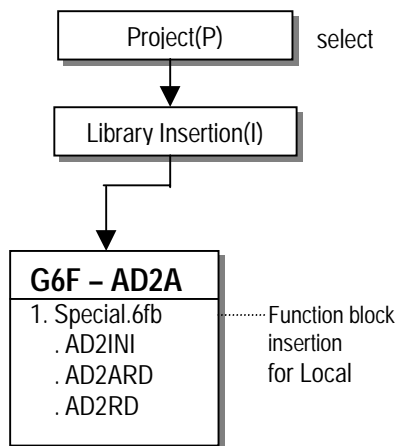

4.2 Function Block for Local

4.2.1 Module Initialization : (AD2INI)

Module Initialization function block is used in a program with setting of A/D conversion module located base number, slot number of located module on base, specifying a channel enable, analog input data type and information of average processing.

Function block	I/O	Variable	Data type	Descriptions
<div style="border: 1px solid black; padding: 5px; width: fit-content;"> AD2INI REQ DONE BASE STAT SLOT ACT CH DATA TYPE AVG_FN AVG_NUM </div>	Input	REQ	BOOL	Function Block Execution Request Area - The execution of function block initialization is requested in this area. - If the status of condition connected with this area is changed from low(0) to high(1), function block initialization for the module is executed.
		BASE	USINT	Base Location Number Area - The base No. on which A/D conversion module is mounted is written on this area. - Setting range : 0 to 1
		SLOT	USINT	Slot Location Number Area - The slot No. on which A/D conversion module is mounted is written on this area. - Setting range: 0 to 7
		CH	BOOL[4]	Available Channel Specification Area - Enabled channels are specified to 1 and disabled channels are specified to 0.
		DATA TYPE	BOOL[4]	Digital Output Data Type Specification Area - 0 is for the range of -48 ~ 4047 - 1 is for the range of -2048 ~ 2047
		AVG_EN	BOOL[4]	Enable / Disable of Average processing - 0 is for the sampling processing. - 1 is for the average processing for the number of times.
		AVG_NUM	USINT[4]	Set a constant of the average processing of the number of times. - Setting range : 2 ~ 255
	Output	DONE	BOOL	Function Block Execution Complete Area - When function block initialization is executed with no error, 1 is written and 1 is kept until next execution. When error occurs, 0 is written and operation come to stop.
		STAT	USINT	Error Code Display Area - When error occurs during function block initialization, the error code number is written.
		ACT	BOOL[4]	Channel Operation Display Area - The channel specified after executing the function block initialization with no error is right, 1 is written and, on the non-specified channel, 0 is written.

REMARK

BOOL[4] and USINT[4] of data type means that the number of element is 4, and also this means the whole number of channels and channel number.

4.2.2 Module Reading-Array Type : (AD2ARD)

Array type of function block for reading is performed for all channels in module and the specified channel is used to read output variable of data displayed from A/D conversion digital value.

Function block	I/O	Variable	Data type	Descriptions
<div style="border: 1px solid black; padding: 5px; width: fit-content;"> AD2ARD REQ DONE BASE STAT SLOT ACT CH DATA </div>	Input	REQ	BOOL	Function Block Execution Request Area - The execution of function block reading is requested in this area. - If input condition is changed from low(0) to high(1), function block initialization for the module is executed.
		BASE	USINT	Base Module Location Number Area - The base No. on which A/D conversion module is mounted is written on this area. - Setting range : 0 ~ 1
		SLOT	USINT	Slot Location Number Area - The slot No. on which A/D conversion module is mounted is written on this area. - Setting range: 0 to 7
		CH	BOOL[4]	Available Channel Specification Area - Available channels are specified in this area. - Enabled channels are specified to 1 and disabled channels are specified to 0.
	Output	DONE	BOOL	Function Block Execution Complete Area - When function block reading is executed with no error, 1 is written and 1 is kept until next execution. When error occurs, 0 is written and operation come to stop
		STAT	USINT	Error Code Display Area - When error occurs during function block reading, the error code number is written. - Error code is referred to Manual 4.3.
		ACT	BOOL[4]	Channel Operation Display Area - The channel specified after executing the function block read with no error is right, 1 is written and, on the non-specified channel, 0 is written
		DATA	INT[4]	A/D Conversion Value Output Area - Output data range : -48 ~ 4047 or -2048 ~ 2047

4.2.3 Module Reading - Single Type : (AD2RD)

Single type of function block for reading the module is performed for only one channel and the specified channel is used to read output variable of data displayed from A/D conversion digital value.

Function block	I/O	Variable	Data type	Descriptions
<div style="border: 1px solid black; padding: 5px; width: fit-content;"> AD2RD REQ DONE BASE STAT SLOT DATA CH </div>	Input	REQ	BOOL	Function Block Execution Request Area - The execution of function block reading is requested in this area. - If input condition is changed from low(0) to high(1), function block initialization for the module is executed.
		BASE	USINT	Base Module Location Number Area - The base No. on which A/D conversion module is mounted is written on this area. - Setting range : 0 ~ 1
		SLOT	USINT	Slot Location Number Area - The slot No. on which A/D conversion module is mounted is written on this area. - Setting range: 0 to 7
		CH	BOOL[4]	Available Channel Specification Area Setting range : 0 ~ 3
	Output	DONE	BOOL	Function Block Execution Complete Area - When function block reading is executed with no error, 1 is written and 1 is kept until next execution. When error occurs, 0 is written and operation come to stop
		STAT	USINT	Error Code Display Area - When error occurs during function block reading, the error code number is written. - Error code is referred to Manual 4.3.
		DATA	INT[4]	A/D Conversion Value Output Area - Output data range : -48 ~ 4047 or -2048 ~ 2047

4.3 Errors on Function Block

This shows errors and resolutions in accordance with them.

STAT No.	Descriptions	Function block			Measures
		Initiali- zation	Read		
			Array type	Single type	
0	Operating with no fault	0	0	0	-
1	The base location number is exceeding the proper setting range	0	0	0	Correct the number in accordance with the proper range
2	H/W error of the base	0	0	0	Contact the service station
3	The slot location number is exceeding the proper setting range	0	0	0	Set the right number to the slot loading the A/D conversion module
4	The A/D conversion module on the slot is empty	0	0	0	Load the A/D conversion module to the specified slot
5	The module loaded isn't the A/D module	0	0	0	Load the A/D conversion module to the specified slot
6	The channel number is exceeding the proper range	-	-	0	Specify the available channel correctly
7	H/W error of the A/D conversion module	0	0	0	Contact the service station
8	The A/D conversion module's shared memory error	0	0	0	Contact the service station
9	The available channels are not specified	-	0	0	Make a correct specification of the available channel on the initialize function block
17	The number of times for average / time value exceeding the proper range	0	-	-	Correct the value to the proper range Setting range : 2 ~255

Chapter 5. PROGRAMMING

5.1 Programming for Distinction of A/D Conversion Value

1) System Configuration

GM6-PAFB	GM6-CPUA	G6F-AD2A	G6Q-RY2A
----------	----------	----------	----------

2) Initial Settings

- (1) Available channel enable : channel 0, 2, 3
- (2) Analog input : current input(DC4 ~ 20 mA)
- (3) Average processing setting : channel 2(100 times), channel 3(50 times)

3) Descriptions of the Program

- (1) The digital value less than 2,000 of channel 0 turns %Q0.1.0 on.
- (2) The digital value more than 3,600 of channel 2 turns %Q0.1.1 on.
- (3) The digital value more than 2,000 or same, and less than 3,600 or same of channel 3 turns %Q0.1.2 on.
- (4) The digital value of the same as 2,800 of channel 3 turns %Q0.1.3 on.

4) Programming Example

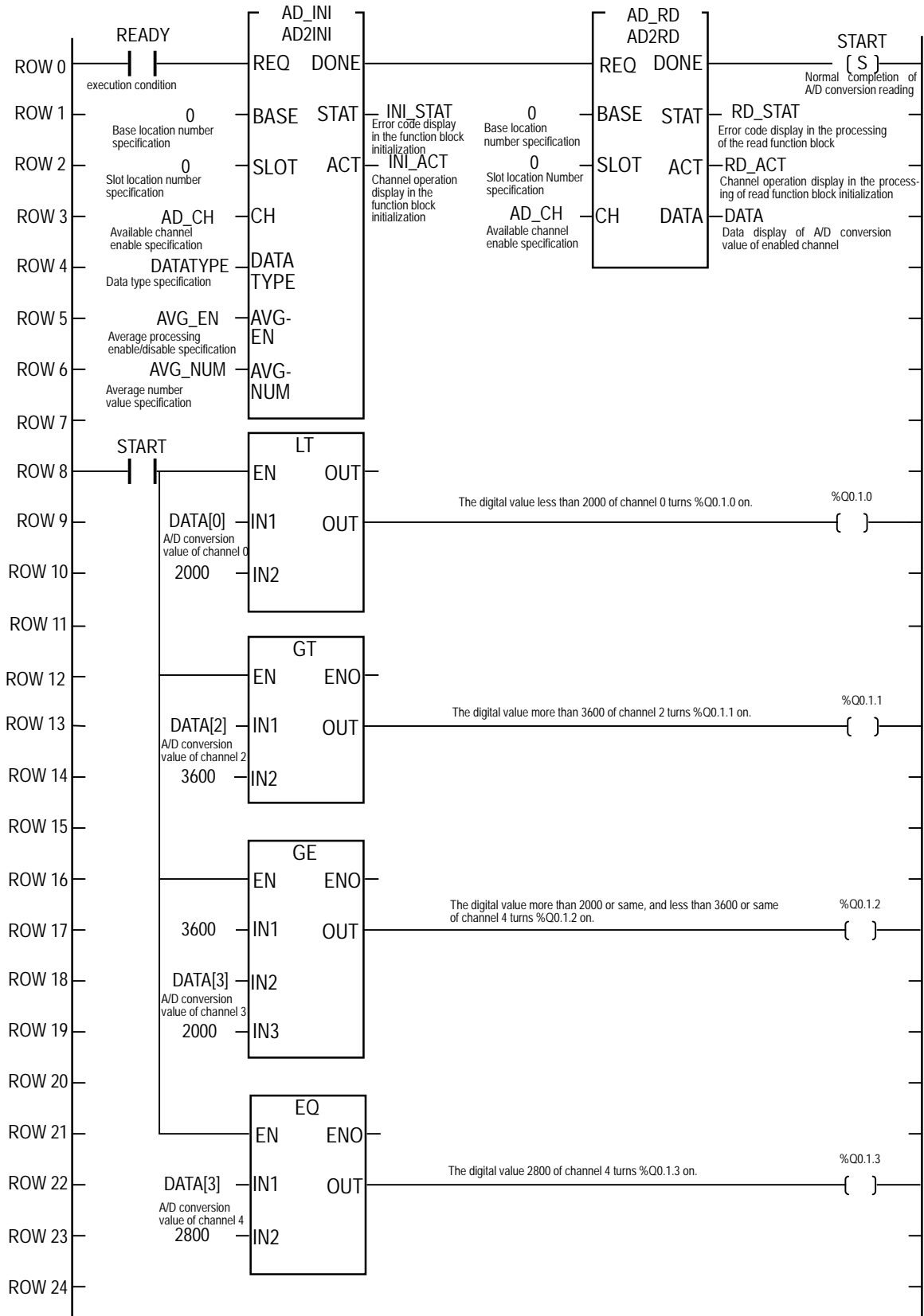

5) Specifying initial value of input/output variables on the program.(Specifying channels)

The image shows three sequential dialog boxes used for configuring an array variable:

- Add/Edit Variables:** Shows the variable name 'AD_CH' and 'Variable Kind' set to 'VAR'. Under 'Data Type', the 'Array' option is selected with '(0..3)' of 'BOOL'. The 'Memory Allocation' section has 'Auto' selected. An arrow points to the 'Array' radio button with the text 'Select this and this screen appears'. Another arrow points to the 'Inl. Array...' button with the text 'This denotes 4 channels'.
- Initialize Array:** Shows the array name 'AD_CH : ARRAY [0..3] OF BOOL'. The 'Initialize' radio button is selected. Below, a table shows channel numbers and their states:

[0]	0
[1]	0
[2]	0
[3]	0

 An arrow points to the first column with the text 'Channel No.'. Below the table, text reads 'Enabled channel : 1' and 'Disabled channel : 0'. An arrow points to the 'Initialize' radio button with the text 'Select this and this screen appears'.
- Initialize Array Element:** Shows the 'Array Element Name' as 'AD_CH[0]' and the 'Initial Value' as '0'. 'Prev Item' and 'Next Item' buttons are visible. An arrow points to the 'Next Item' button with the text 'To select next Ch.'. Another arrow points to the 'Initial Value' field with the text 'To specify channel enable/disable'.

6) Input/output variables on Programming

Variable Name	Var_Kind	Data Type	(AT Address) (Initial Value)
AD_CH	: VAR	: ARRAY [0..3] OF BOOL	: = { 1,0,1,1 }
AD_INI	: VAR	: FB instance	
AD_RD	: VAR	: FB instance	
AVG_EN	: VAR	: ARRAY [0..3] OF BOOL	: = { 0,1,0,1 }
AVG_NUM	: VAR	: ARRAY [0..3] OF USINT	: = { 0,0,100,50 }
DATA	: VAR	: ARRAY [0..3] OF INT	
DATATYPE	: VAR	: ARRAY [0..3] OF BOOL	: = { 0,0,0,0,0,0,0,0,0,0,0,0,0 }
INI_ACT	: VAR	: ARRAY [0..3] OF BOOL	
INI_STAT	: VAR	: USINT	
RD_ACT	: VAR	: ARRAY [0..3] OF BOOL	
RD_STAT	: VAR	: USINT	
READY	: VAR	: BOOL	
START	: VAR	: BOOL	

5.2 Programming for Display of A/D Conversion Value and Error Code on BCD Display

1) System Configuration

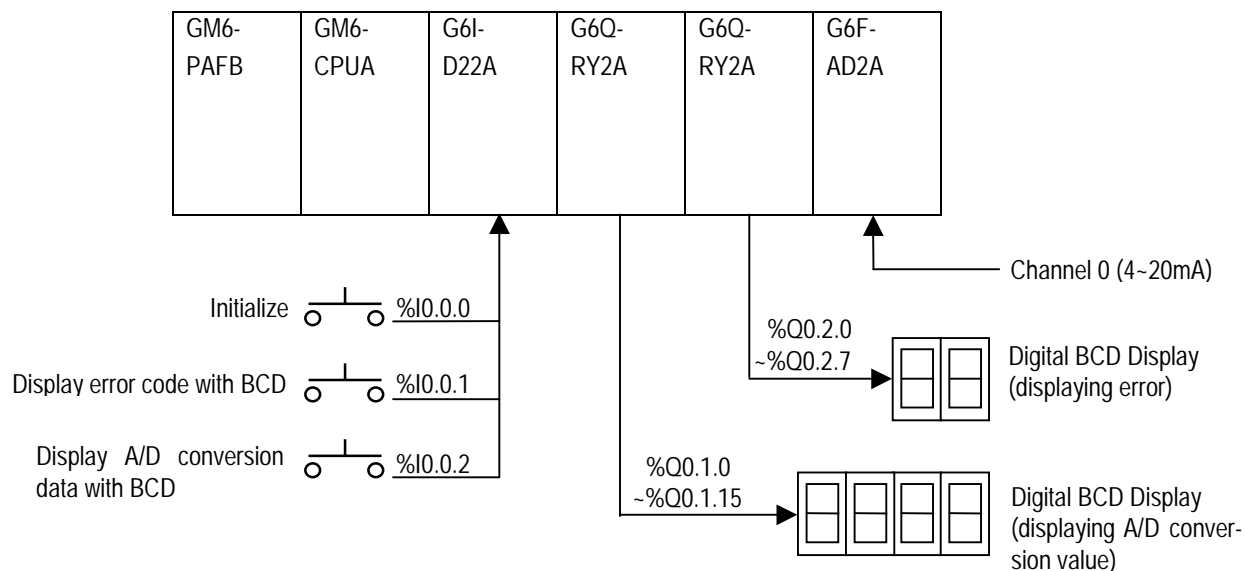

2) Initial Settings

- (1) Available channel enabled : channel 0,
- (2) Analog input : current input(DC 4 to 20 mA)
- (3) Average processing setting : 10 times

3) Descriptions of the Program

- (1) %I0.0.0 turning On leads to the initial setting of A/D conversion module.
- (2) %I0.0.1 turning On leads to displaying A/D conversion value on the BCD display.(%Q0.1.0 to %Q0.1.15)
- (3) %I0.0.2 turning On leads to displaying error code of function block on the BCD display, (%Q0.2.0 to %Q0.2.7)

Chapter 2. PROGRAMMING

4) Programming

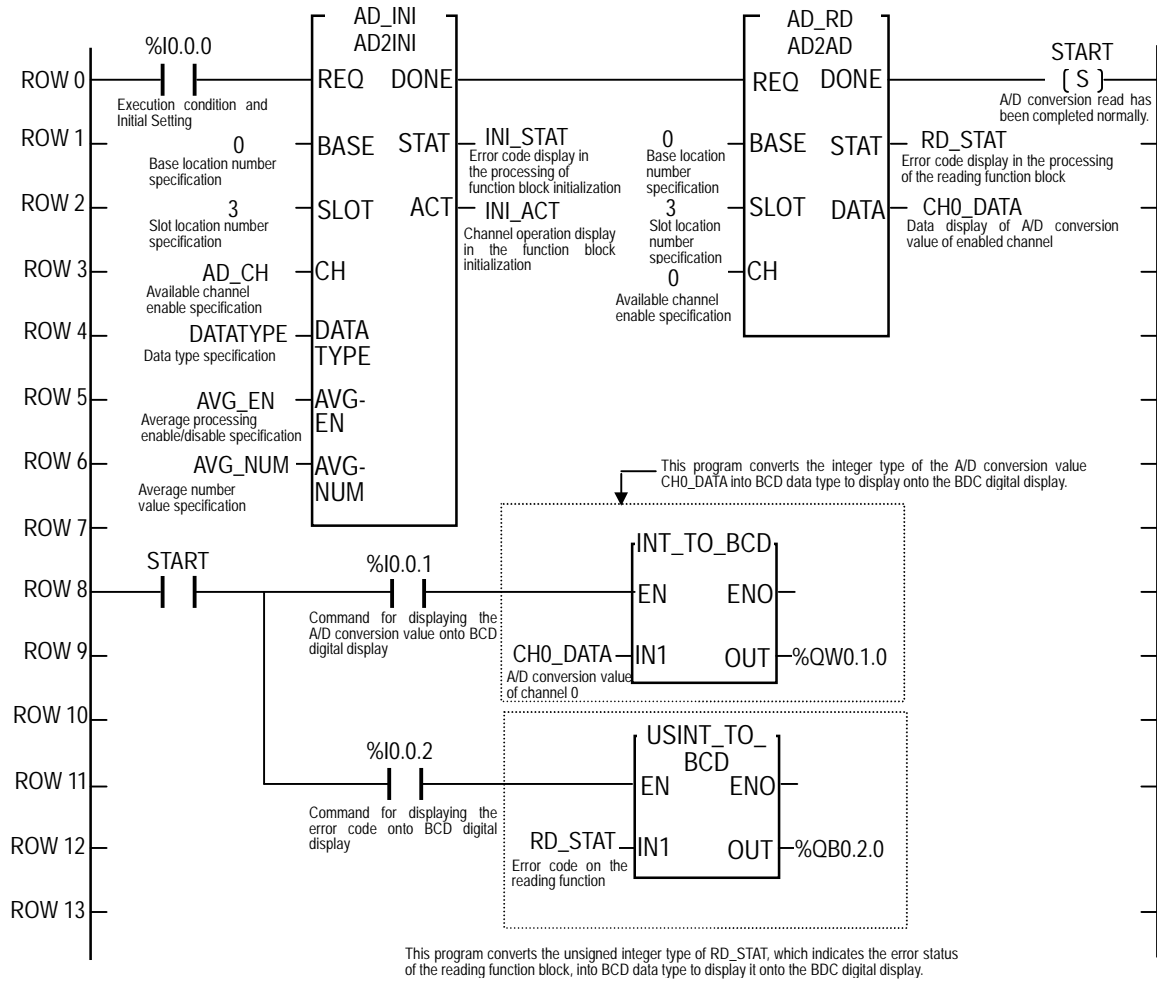

5) Input/output variables on the programming

Variable Name	Var_Kind	Data Type	(AT Address) (Initial Value)
AD_CH	: VAR	: ARRAY [0..3] OF BOOL	:= {1,0,0,0}
AD_INI	: VAR	: FB Instance	
AD_RD	: VAR	: FB Instance	
AVG_EN	: VAR	: ARRAY [0..3] OF BOOL	:= {1,0,0,0}
CH0_DATA	: VAR	: INT	
DATA	: VAR	: DINT	
DATATYPE	: VAR	: ARRAY [0..3] OF BOOL	:= {0,0,0,0}
INI_ACT	: VAR	: ARRAY [0..3] OF BOOL	
INI_STAT	: VAR	: USINT	
NUM_TIME	: VAR	: ARRAY [0..3] OF UINT	:= {100,0,0,0}
RD_STAT	: VAR	: USINT	
START	: VAR	: BOOL	

Chapter 6. DIMENSIONS

6.1 G6F-AD2A

(Unit : mm)

