



DX8200A

QUICK REFERENCE GUIDE



UPDATES AND LANGUAGE AVAILABILITY

- UK/US** The latest drivers and documentation updates for this product are available on Internet.
Log on to: www.automation.datalogic.com
- I** Su Internet sono disponibili le versioni aggiornate di driver e documentazione di questo prodotto. Questo manuale è disponibile anche nella versione italiana.
Collegarsi a: www.automation.datalogic.com
- F** Les versions mises à jour de drivers et documentation de ce produit sont disponibles sur Internet. Ce manuel est aussi disponible en version française.
Cliquez sur : www.automation.datalogic.com
- D** Im Internet finden Sie die aktuellsten Versionen der Treiber und Dokumentation von diesem Produkt. Die deutschsprachige Version dieses Handbuchs ist auch verfügbar.
Adresse : www.automation.datalogic.com
- E** En Internet están disponibles las versiones actualizadas de los drivers y documentación de este producto. También está disponible la versión en español de este manual.
Dirección Internet : www.automation.datalogic.com

SERVICES AND SUPPORT

Datalogic provides several services as well as technical support through its website. Log on to www.automation.datalogic.com and click on the [links](#) indicated for further information:

- **PRODUCTS**

Search through the links to arrive at your product page which describes specific Info, Features, Applications, Models, Accessories, and Downloads including the [Genius™](#) utility program, which allows device configuration using a PC. It provides RS232 and Ethernet interface configuration.

- **SERVICE**

- **Overview** - Warranty Extensions and Maintenance Agreements
- **Sales Network**- Listing of Subsidiaries, Repair Centers, Partners
- **Helpdesk**
- **Material Return Authorization**

LEGAL NOTICES

© 2005 - 2010 Datalogic Automation S.r.l. ♦ ALL RIGHTS RESERVED. ♦ Protected to the fullest extent under U.S. and international laws. Copying, or altering of this document is prohibited without express written consent from Datalogic Automation S.r.l.

Datalogic and the Datalogic logo are registered trademarks of Datalogic S.p.A. in many countries, including the U.S.A. and the E.U.

Genius, PackTrack, ACR, ASTRA, CD SQUARE and ID-NET are trademarks of Datalogic Automation S.r.l. All other brand and product names mentioned herein are for identification purposes only and may be trademarks or registered trademarks of their respective owners.

Datalogic shall not be liable for technical or editorial errors or omissions contained herein, nor for incidental or consequential damages resulting from the use of this material.

DX8200A GENERAL VIEW

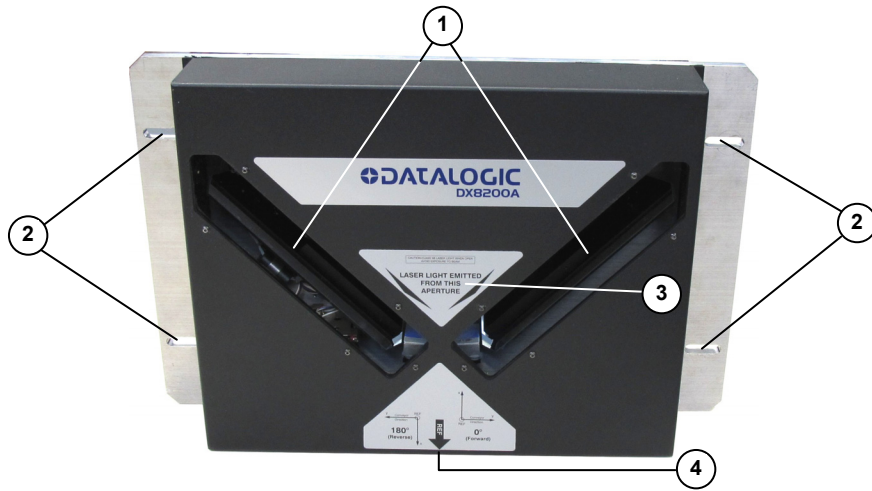

Figure A

- ① Laser Beam Output Windows
- ② Mounting Slots
- ③ Laser Safety Label
- ④ Mounting Reference Label



Figure B

- ① Programming Keypad
- ② Power On LED (Green)
- ③ Phase On LED (Yellow)
- ④ Encoder LED (Yellow)
- ⑤ TX Data LED (Green)
- ⑥ Network LED (Red)
- ⑦ LCD Display

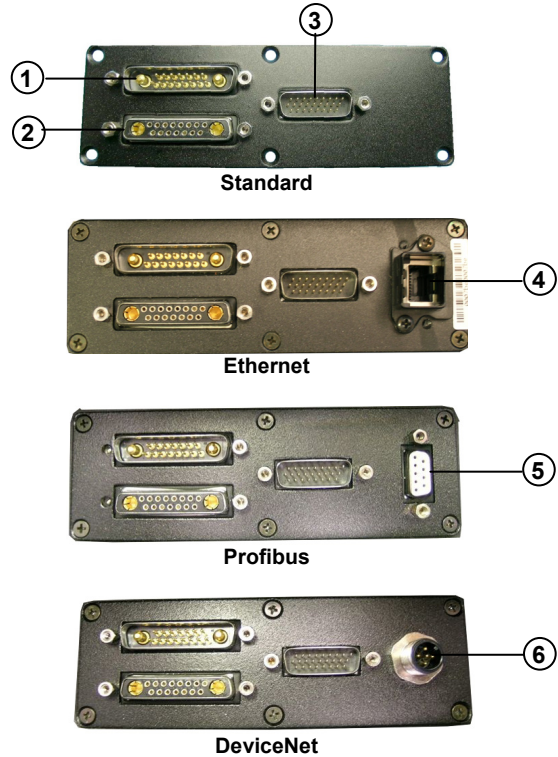

Figure C

- ① Lonworks 17-pin Male Connector
- ② Lonworks 17-pin Female Connector
- ③ Serial Interface and I/O 26-pin male Connector
- ④ Harting RJ Industrial® Modular female Connector
- ⑤ Profibus 9-pin female Connector
- ⑥ DeviceNet 5-pin male Connector

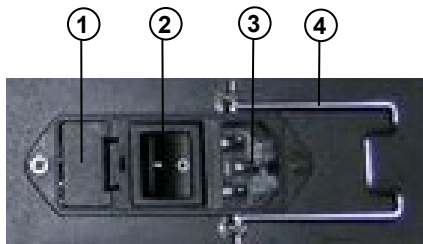

Figure D
(VAC Models Only)

- ① Line Fuses
- ② Line Switch
- ③ Power Inlet
- ④ Cord Retaining Clamp



NOTE

For further details on product installation, see the complete Reference Manual available on the configuration CD-ROM included with this product.

CONNECTIVITY

Examples of the most common system layouts are shown in this section, for additional layouts refer to the Reference Manual.

Local Lonworks Networks

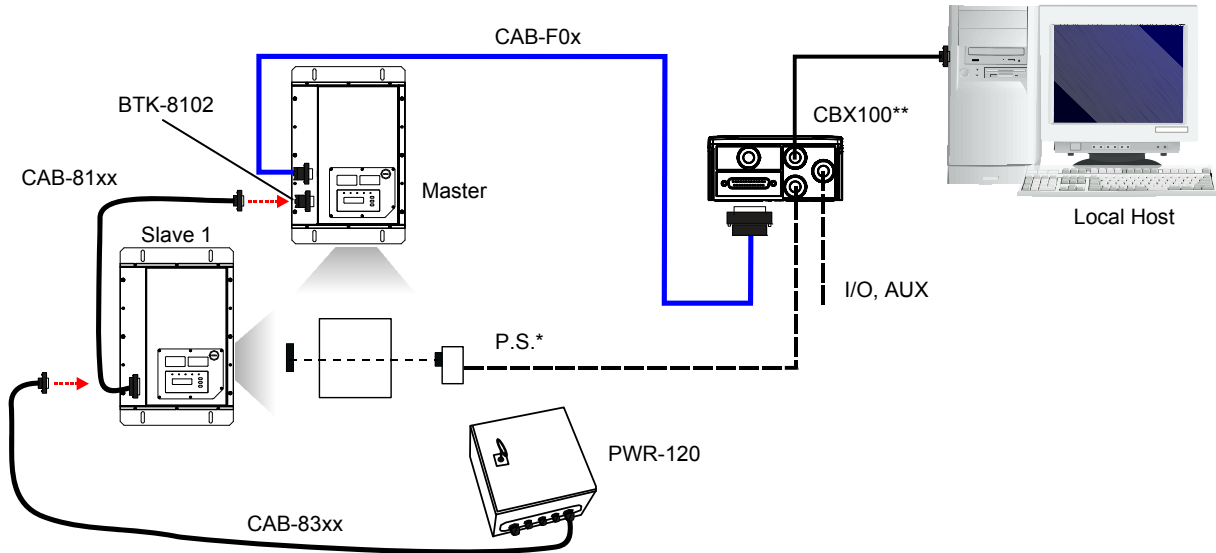

* P.S. (Presence Sensor) connected to Input 1 (External Trigger/PS) input.

** CBX100 jumper set to accept scanner power.

Small Synchronized Network with 2 Readers

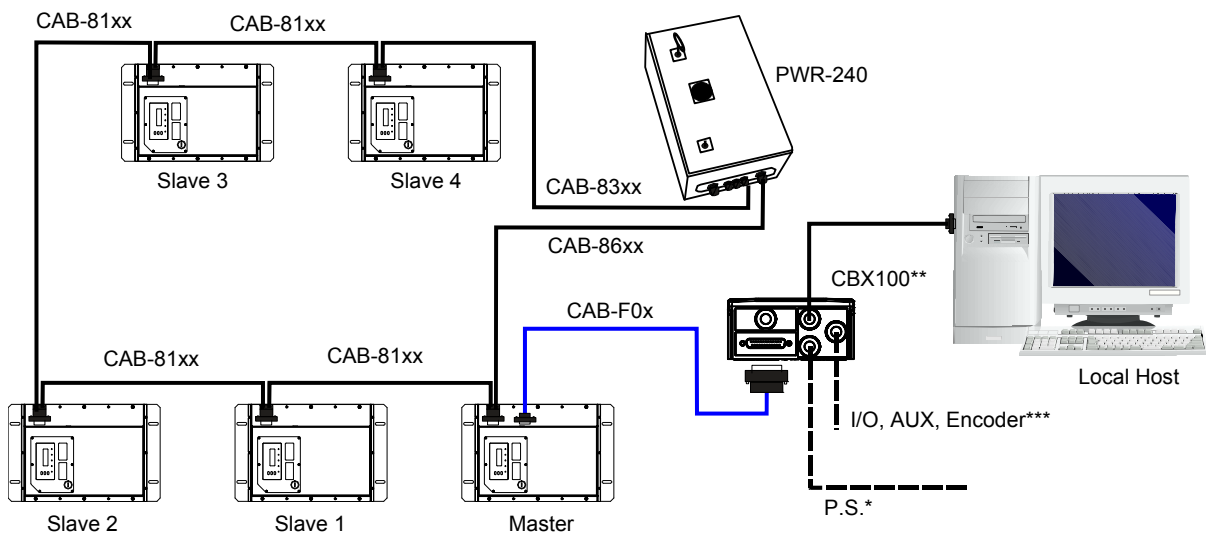

* P.S. (Presence Sensor) connected to Input 1 (External Trigger/PS) input.

** CBX100 jumper set to accept scanner power.

*** Encoder connected to Input 2 (Encoder) input.

Small Synchronized Network with more than 2 Readers and Single Power Unit

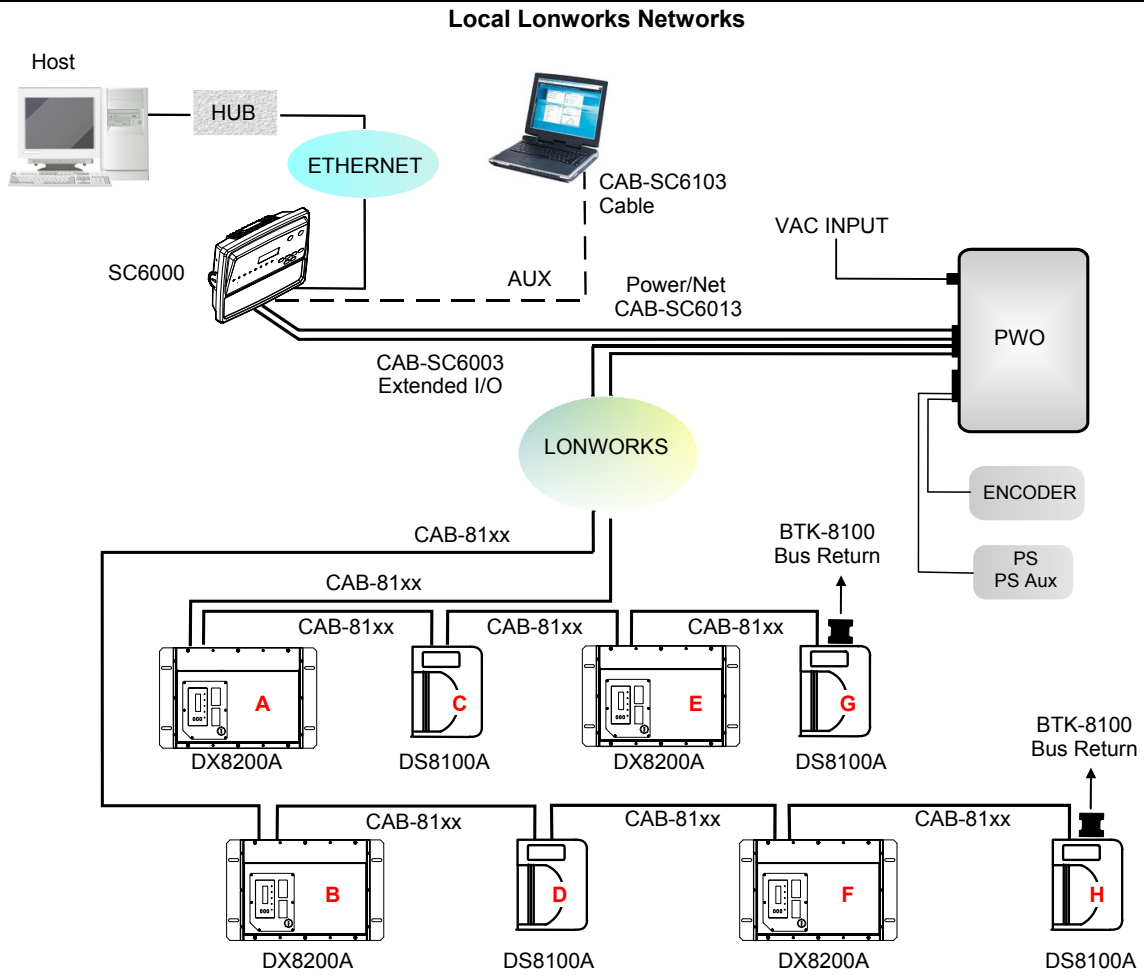

Large Synchronized Network with DX8200A and DS8100A Scanners

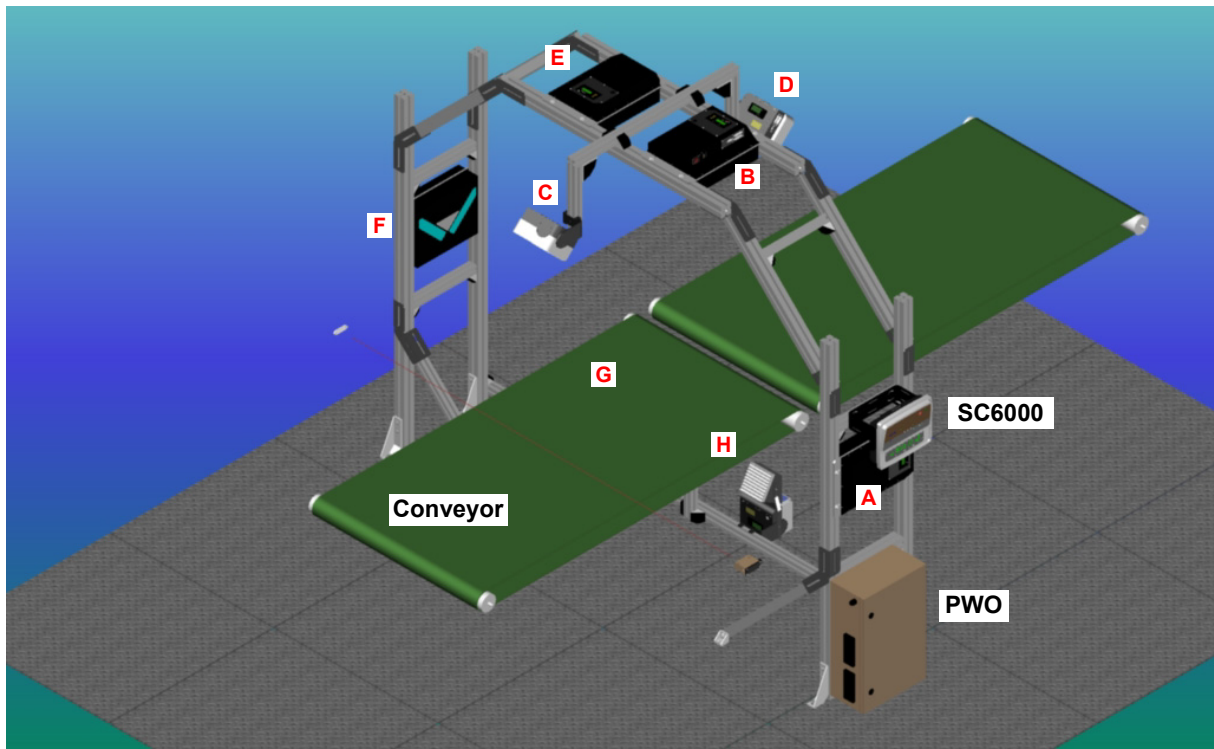

Example Large Synchronized Network Reading Station

NETWORK TERMINATION

When building a Lonworks system the network must be properly terminated by positioning the BTK-8102 Lonworks terminator in the DX8200A master reader and the BTK-8100 Lonworks bus return in the last DX8200A slave reader.

The BTK-8100 bus return provides a connector to be inserted in the Lonworks 17-pin female connector of the last slave reader in the network; while the BTK-8102 Lonworks terminator provides a different connector to be inserted in the Lonworks 17-pin male connector of the master reader:

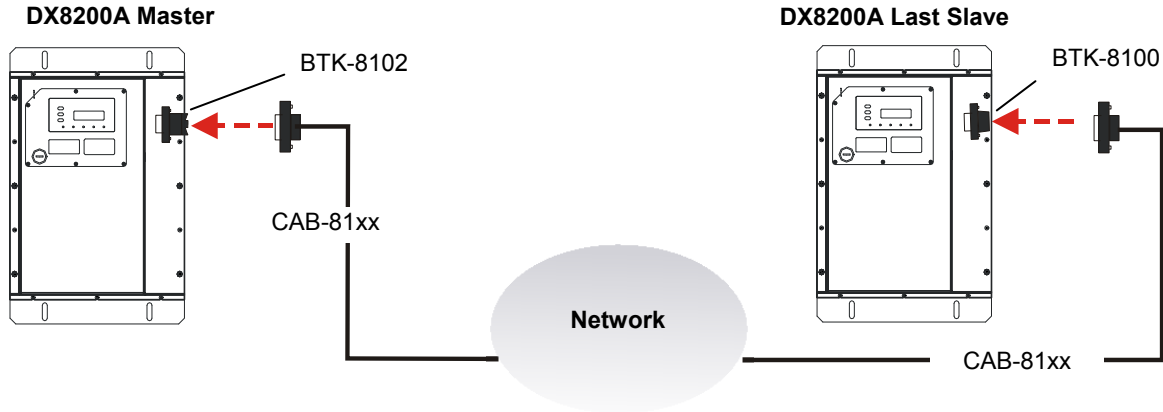

BTK-8102 and BTK-8100

Two cables are also provided as accessories to terminate and power the network: CAB-8605 and CAB-8305.

CAB-8605 is a power and Lonworks termination cable to be used for connecting the DX8200A master to an external power unit within the network; while CAB-8305 is a power and bus return cable to be used for connecting the last DX8200A slave to an external power unit. **These two cables must only be used for VDC models.**

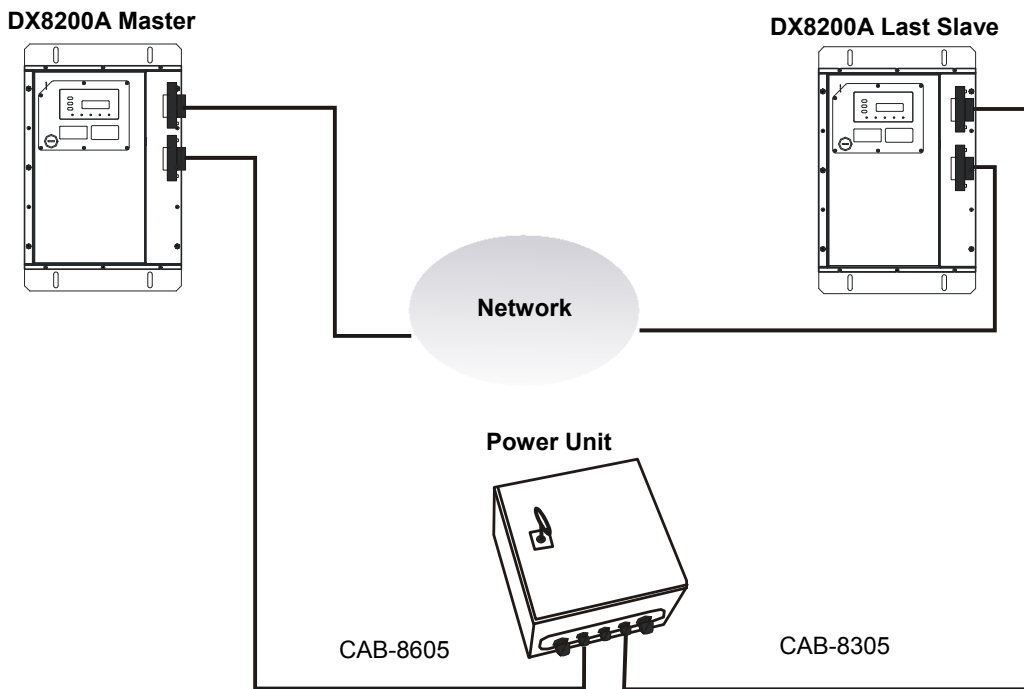

CAB-8605 and CAB-8305

ELECTRICAL CONNECTIONS

The details of the connector pins are indicated in the following tables:

The table below gives the pinout of the CBX100/CBX500 terminal block connectors. Use this pinout when the DX8200A reader is connected by means of the CBX100/CBX500:

CBX100/500 Terminal Block Connectors			
Power			
Vdc	Power Supply Input Voltage +		
GND	Power Supply Input Voltage -		
Earth	Protection Earth Ground		
Inputs			
+V	Power Source – Inputs		
-V	Power Reference – Inputs		
I1A	EXT TRIG/PS A (polarity insensitive) for PS		
I1B	EXT TRIG/PS B (polarity insensitive) for PS		
I2A	IN 2/ENC A (polarity insensitive) for Encoder		
I2B	IN 2/ENC B (polarity insensitive) for Encoder		
I3A	IN 3A (polarity insensitive) (only with CBX500)		
I4A	IN 4A (polarity insensitive) (only with CBX500)		
I34B	IN 3B/IN 4B Reference (polarity insensitive) (only with CBX500)		
Outputs			
+V	Power Source - Outputs		
-V	Power Reference - Outputs		
O1+	OUT 1+		
O1-	OUT 1-		
O2+	OUT 2+		
O2-	OUT 2-		
O3A	OUT 3A (polarity insensitive) (only with CBX500)		
O3B	OUT 3B (polarity insensitive) (only with CBX500)		
Auxiliary Interface			
TX	Auxiliary Interface TX		
RX	Auxiliary Interface RX		
SGND	Auxiliary Interface Reference		
Shield			
Shield	Network Cable Shield		
Main Interface			
	RS232	RS485 Full-Duplex	RS485 Half-Duplex
	TX	TX+	RTX+
	RTS	TX-	RTX-
	RX	*RX+	
	CTS	*RX-	
	SGND	SGND	SGND

* Do not leave floating, see Reference Manual for connection details.



CAUTION

Do not connect GND and SGND to different (external) ground references. GND and SGND are internally connected through filtering circuitry which can be permanently damaged if subjected to voltage drops over 0.8 Vdc.

The DX8200A scanner provides a 26-pin male D-sub connector for connection to power supply, Host interface (Main and Aux), and input/output signals.

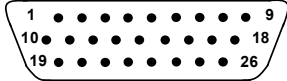
26-pin D-Sub Connector Pinout			
Pin	Name	Function	
1	CHASSIS	Chassis - internally connected to GND	 <p>26-pin male D-sub Connector</p>
20	RXAUX	Cable shield connected to chassis	
21	TXAUX	Receive data of auxiliary RS232 (referred to GND)	
8	OUT 1+	Transmit data of auxiliary RS232 (referred to GND)	
22	OUT 1-	Configurable digital output 1 – positive pin	
11	OUT 2+	Configurable digital output 1 – negative pin	
12	OUT 2-	Configurable digital output 2 – positive pin	
16	OUT 3A	Configurable digital output 2 – negative pin	
17	OUT 3B	Configurable digital output 3 – polarity insensitive	
18	EXT_TRIG/PS A	Configurable digital output 3 – polarity insensitive	
19	EXT_TRIG/PS B	External trigger (polarity insensitive) for PS	
6	IN2/ENC A	External trigger (polarity insensitive) for PS	
10	IN2/ENC B	Input signal 2 (polarity insensitive) for Encoder	
14	IN3A	Input signal 2 (polarity insensitive) for Encoder	
15	IN4A	Input signal 3 (polarity insensitive)	
24	IN_REF	Input signal 4 (polarity insensitive)	
9, 13	VS	Common reference of IN3 and IN4 (polarity insensitive)	
23, 25, 26	GND	Supply voltage – positive pin	
		Supply voltage – negative pin	
Main Interface			
Pin	RS232	RS485 Full-Duplex	RS485 Half-Duplex
2	TX	TX485+	RTX485+
3	RX	* RX485+	
4	RTS	TX485-	RTX485-
5	CTS	* RX485-	
7	GND_ISO	GND_ISO	GND_ISO

* Do not leave floating, see Reference Manual. for connection details.

Two 17-pin connectors provide access to the scanner's local Lonworks network used for both input and output connections to build a multi-sided or omni-station system.

17-pin Lonworks Connector Pinout		
Pin	Name	Function
A1	GND	Supply voltage (negative pin)
A2	VS	Supply voltage 20 to 30 Vdc (positive pin)
1	CHASSIS	Cable shield A - internally connected by capacitor to chassis
2	n.c.	Not connected
3	CHASSIS	Cable shield B - internally connected by capacitor to chassis
4	n.c.	Not connected
5	n.c.	Not connected
6	n.c.	Not connected
7	VS_I/O	Supply voltage of I/O circuit
8	Lon A+	Lonworks a line (positive pin)
9	Lon A-	Lonworks a line (negative pin)
10	Lon B+	Lonworks b line (positive pin)
11	Lon B-	Lonworks b line (negative pin)
12	SYS_I/O	System signal
13	SYS_ENC_I/O	System signal
14	Reserved	Internally connected
15	Ref I/O	Reference voltage of I/O circuit

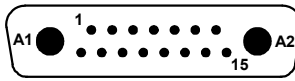

Male - Input

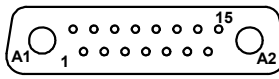

Female - Output

17-pin Local Lonworks Connectors

Ethernet Model

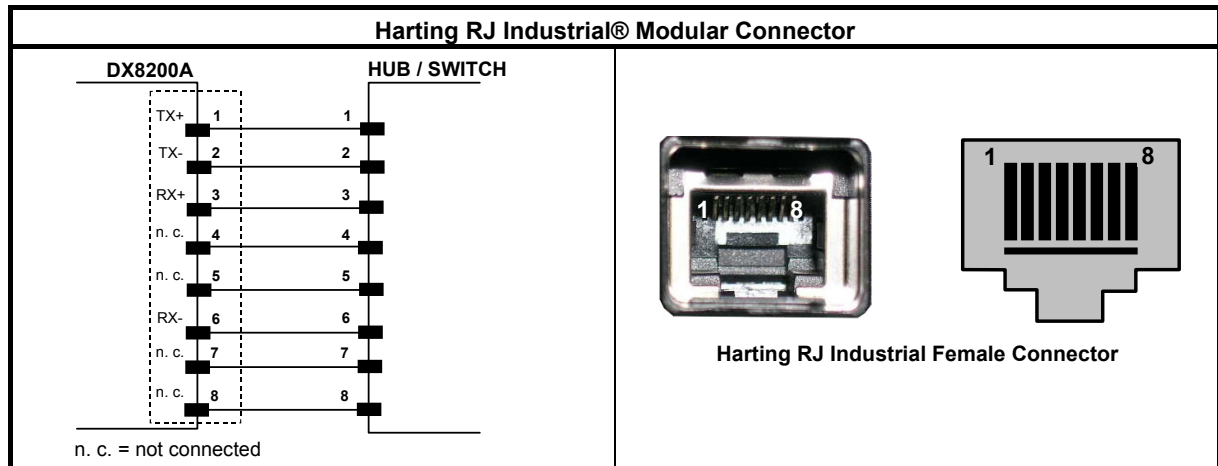

👉

NOTE For Ethernet connections, always use the Harting RJ Industrial® Push Pull Ethernet connector (included in the package). This connector assures a robust connection and full IP rated protection.

Profibus Model

Profibus Connector		
Pin	Name	Function
1	Shield*	Shield, protective ground resp.
2	Free	
3	B-LINE (Rx/D/TxD-P)	Received/Transmitted data-P
4	CNTR-P**	Repeater control signal
5	DGND	Data ground (M5V)
6	+5 V	Voltage plus (P5V)
7	Free	
8	A-LINE (Rx/D/TxD-N)	Received/Transmitted data
9	CNTR-N**	Repeater control signal

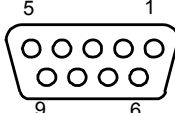

Profibus 9-pin D-sub Female Connector

* signal is optional

** signal is optional; RS485 level

DeviceNet Model

DEVICENET CONNECTOR		
Pin	Name	Function
2	V+	Supply voltage – positive pin
5	CAN_L	CAN bus data line – L
1	SHIELD	Shield
4	CAN_H	CAN bus data line – H
3	V-	Supply voltage – negative pin

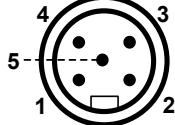

5-pin male DeviceNet Connector

APPENDIX

TECHNICAL FEATURES

ELECTRICAL FEATURES		
	VAC models	VDC models
Supply Voltage	110 to 230 Vac	20 to 30 Vdc
Power Consumption	30 VA typical 1.75 to 1.17 A; 35 W Max. (including startup current)	1.5 to 1.0 A; 30 W typical
Common Communication Interfaces	Main	Baud Rate 1200 to 115200
	RS232	
	RS485 full-duplex	
	RS485 half-duplex	
	Auxiliary	1200 to 115200
	RS232	
	Other	
Lonworks	1.25 Mb/s	
Model-Dependent Communication Interfaces	Ethernet DeviceNet Profibus	100 Mb/s up to 500 K/bs up to 12 M/bs
Inputs Ext. Trigger 1, Encoder 2 aux. digital inputs	(optocoupled NPN or PNP)	
Outputs 3 software programmable digital outputs	(optocoupled)	
OPTICAL FEATURES		
Light Receiver	Avalanche photodiode	
Wavelength	630 to 680 nm	
Safety Class	Class 2 - EN60825-1; Class II - CDRH	
Light Source	Up to 4 semiconductor laser diodes	
Laser Control	Security system to turn laser off in case of motor slow down	
READING FEATURES		
Scan rate	≤ 1000 scans/s (500 per leg)	
Maximum Resolution Max. Reading Distance Max. Reading Width Max. Depth of Field	(see reading diagrams on page 15)	
USER INTERFACE		
LCD Display	2 lines by 20 characters LCD	
Keypad	3 keys	
LED Indicators	Power On (green) Phase On (yellow) Encoder (yellow) TX Data (green) Network (red)	

SOFTWARE FEATURES	
Readable Codes	Interleaved 2/5 Code 39 Standard Codabar Code 128 EAN 128 Code 93 (standard and full ASCII) EAN/UPC (including Add-on 2 and Add-on 5) GS1 DataBar (including Limited and Expanded)
Code Selection	Up to 10 codes during one reading phase
Headers and Terminators	Up to 128-bytes headers and 128-bytes terminators
Operating Modes	On Line, Serial On Line, Automatic, Test, PackTrack™, Continuous
Configuration Modes	Genius™ utility program
Parameter Storage	Non-volatile internal FLASH
ENVIRONMENTAL FEATURES	
Operating Temperature	0° to +50 °C (+32° to +122 °F)
Storage Temperature	-20° to +70 °C (-4° to +158 °F)
Humidity	90% non condensing
Ambient Light Immunity	20000 lux
Vibration Resistance EN 60068-2-6 2 hours on each axis	Frequency range from 5 to 150 Hz; Constant displacement 3 mm pk-pk from 5 to 9 Hz; Constant acceleration 0.5 g from 9 to 150 Hz;
Shock Resistance EN 60068-2-27 3 shocks on each axis	30 g; 11 ms
	VAC models VDC models
Protection Class – EN 60529	IP40 IP64*
PHYSICAL FEATURES	
Mechanical Dimensions	470 x 300 x 141 mm (18.50 x 11.81 x 5.55 in)
Weight	about 11 kg (24 lbs. 3 oz.)

* sealed connectors required, including the Harting RJ Industrial® Push Pull Ethernet connector for Ethernet models.

MODEL DESCRIPTION

DX8200A - 3 X Y Z

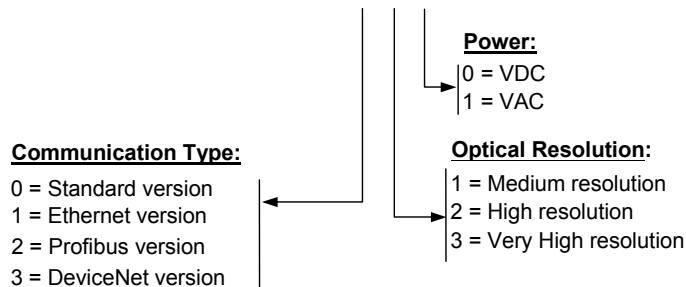

ACCESSORIES

Name	Description	Part Number
Power Supplies		
PWR-120	J-box power unit 110/230 VAC 24 V 120 W	93ACC1530
PWR-240	J-box power unit 110/230 VAC 24 V 240 W	93ACC1070
PWR-480A	J-box power unit 110/230 VAC 24 V 480 W	93ACC1850
Cables and Terminators		
BTK-8100	Bus terminator kit (5 pcs)	93ACC1090
BTK-8102	Double terminator kit (2 pcs)	93A051287
CAB-8100	10 wire shielded cable D 9.5 mm – 50 m	93ACC1120
CAB-8101	17-pin scanner/scanner connection cable 1.2 m	93A051020
CAB-8102	17-pin scanner/scanner connection cable 2.5 m	93A051030
CAB-8105	17-pin scanner/scanner connection cable 5 m	93A051040
CAB-8305	Power and bus return cable (last Slave) 5 m	93A051268
CAB-8310	Power and bus return cable (last Slave) 10 m	93A051336
CAB-8402	No power cable 2.5 m	93ACC1758
CAB-8405	No power cable 5 m	93ACC1759
CAB-F01	6K-8K FBUS cable to CBX 1 m	93A051355
CAB-F02	6K-8K FBUS cable to CBX 2 m	93A051356
CAB-F05	6K-8K FBUS cable to CBX 5 m	93A051357
CAB-6502	Fam 6K-8K cross cable 2.5 m	93A051288
CAB-6505	Fam 6K-8K cross cable 5 m	93A051289
CAB-8605	Power and Lonworks termination cable (Master) 5 m	93A051290
CAB-DX8000	Power cable DX8200A VAC (EU)	93A051333
CAB-DX8001	Power cable DX8200A VAC (US)	93A051334
Software Management		
Datalogic WebSentinel-005	Supervisor (up to 5 arrays)	93A101014
Datalogic WebSentinel-010	Supervisor (up to 10 arrays)	93A101015
Datalogic WebSentinel-020	Supervisor (up to 20 arrays)	93A101016
Datalogic WebSentinel-032	Supervisor (up to 32 arrays)	93A101017
Datalogic WebSentinel-064	Supervisor (up to 64 arrays)	93A101018
Datalogic WebSentinel-128	Supervisor (up to 128 arrays)	93A101019
Datalogic WebSentinel-256	Supervisor (up to 256 arrays)	93A101020
* Connection Boxes		
CBX100	Compact Connection Box	93A301067
CBX500	Modular Connection Box	93A301068
CBX800	Gateway Connection Box	93A301077
BM100	Backup Module	93ACC1808
BA100	DIN Rail Adapters for CBX	93ACC1821
BA200	Bosch Adapters for CBX	93ACC1822
BA900	Two Cable Glands Panel	93ACC1847
Sensors		
MEP-593	Photocell kit – PNP (PH-1)	93ACC1791
MEP-543	Photocell kit – NPN	93ACC1728
OEK-2	Optical encoder kit (10 m cable + spring)	93ACC1770
OEK-1	Optical encoder kit + 10 m cable	93ACC1600
UPT-80	DX8200A – DX8200 Adapter	93ACC1757
Miscellaneous		
PLL-8000	Optocoupled PLL device	93ACC1280
FS-1	Frame shaper (8 pcs)	93ACC1750

* DX8200A application software does not support any of the CBX500 Host Interface Module accessories nor the BM150 Display accessory. Use the CBX800 Gateway for Host Interface Applications, (Fieldbus and non Fieldbus).

MECHANICAL DIMENSIONS

DX8200A can be installed to operate in any position. There are 4 slots (dia. 8.5 mm) on the sides of the scanner for mounting. The diagram below can be used for installation; refer to the Reading Diagrams for correct positioning of the scanner with respect to the reading zone and scanner orientation.

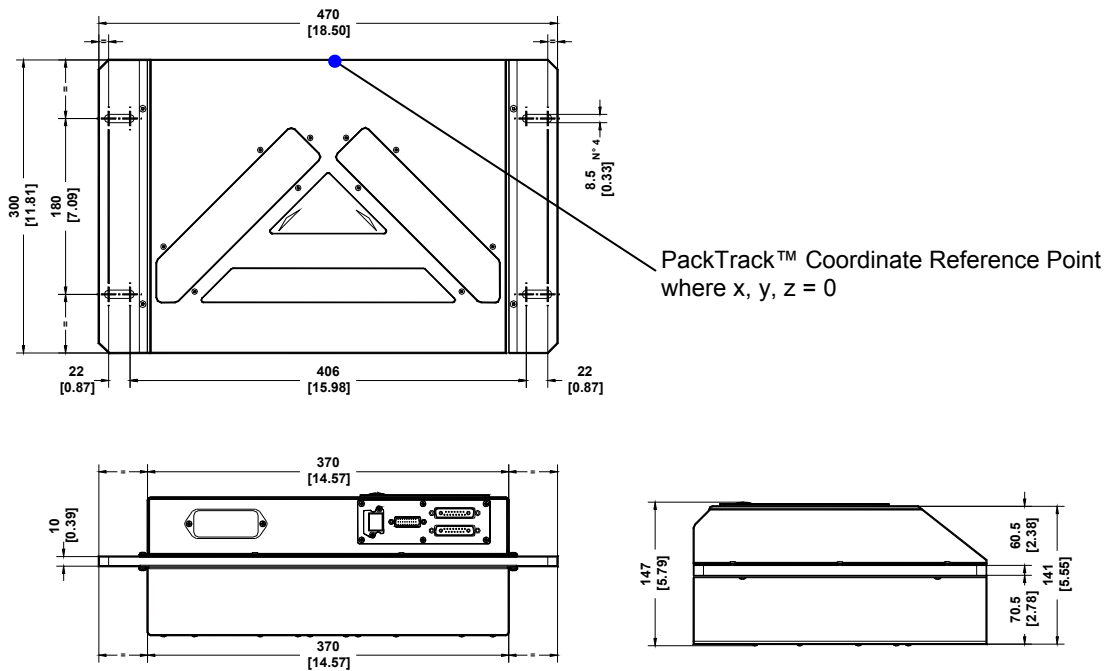

DX8200A Overall Dimensions



WARNING

When installing several scanners, take care to position them correctly so that no laser beam enters the reading window perpendicularly and at the same level of the output beam of the other scanners. This condition could occur more frequently for side mounted applications. If these precautions are not followed, it may occur that the laser of the blinded scanner starts blinking due to an internal circuit which temporarily turns the laser off when detecting a power anomaly. To resolve this problem, it is sufficient to slightly change the inclination and position of one of the two scanners involved.

Mounting Stops

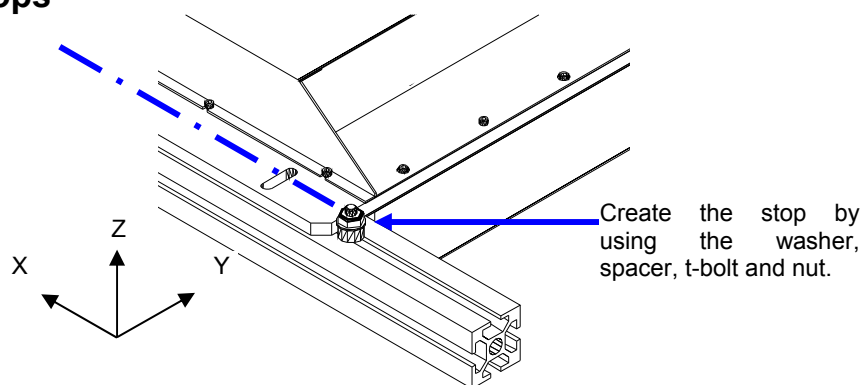

X-axis Reference Point Stops

Two washers and two spacers are provided in the DX8200A package to create two stops which can be used to facilitate DX8200A mounting and positioning. Create each stop by mounting a washer and spacer to the Reading Station Frame using Bosch T-bolts and nuts. See the figure above.

- During initial mounting, affix the stops in approximation to the mounting position. The weight of the DX8200A can rest against this reference while the mounting bolts are being set. This avoids having to hold and maneuver the scanner (especially for vertical side mounted positions) while simultaneously affixing it to the frame.

- Once the scanner is correctly positioned for PackTrack, fix the stops against the scanner. The stops remain fixed to the station frame so that the scanner can be replaced without having to recalibrate the PackTrack coordinates. Referring to the figure above, the stop provides a reference point for the X-axis while the scanner should be centered on the frame to have a fixed reference for the Y-axis.

READING CONDITIONS

- ANSI Grade B minimum
- 500 scans/sec per leg

The following tables describe the requirements for standard applications.

Minimum Code Height for Omnidirectional Reading (mm)							
Conveyor Speed (m/s)		0.5	1	1.5	2	2.5	3
2/5 Interleaved Code Resolution (mm)	0.25	11	13	15	17	19	21
	0.30	12	14	16	18	20	23
	0.33	13	15	17	19	21	23
	0.38	14	16	18	20	23	25
	0.50	18	19	22	24	26	28
	0.72	24	26	27	29	32	34
	1.00	33	34	35	37	39	41

Ratio 3:1

Table 1

Minimum Code Height for Omnidirectional Reading (mm)							
Conveyor Speed (m/s)		0.5	1	1.5	2	2.5	3
Code 39 Code Resolution (mm)	0.25	9	11	13	15	17	19
	0.30	10	11	14	16	18	20
	0.33	11	12	14	16	18	20
	0.38	12	13	15	17	19	21
	0.50	15	16	17	19	21	23
	0.72	20	22	23	24	25	27
	1.00	27	28	29	30	32	33

Ratio 3:1; Interdigit = Module Size

Table 2

Minimum Code Height for Omnidirectional Reading (mm)							
Conveyor Speed (m/s)		0.5	1	1.5	2	2.5	3
Code 128 – Ean 128 Code Resolution (mm)	0.25	8	10	12	14	16	18
	0.30	9	11	13	15	17	19
	0.33	9	11	13	15	18	20
	0.38	10	12	14	16	18	20
	0.50	12	14	16	18	20	22
	0.72	16	18	19	21	24	26
	1.00	22	23	24	26	28	30

Table 3

Minimum Code Height for Omnidirectional Reading (mm)							
Conveyor Speed (m/s)		0.5	1	1.5	2	2.5	3
Codabar Code Resolution (mm)	0.25	8	10	12	14	16	18
	0.30	9	11	13	15	17	19
	0.33	9	11	13	15	18	20
	0.38	10	12	14	16	18	20
	0.50	13	14	16	18	20	22
	0.72	17	18	19	21	24	26
	1.00	23	24	25	26	28	30

Ratio 3:1; Interdigit = Module Size

Table 4

Minimum Code Height for Omnidirectional Reading (mm)							
Conveyor Speed (m/s)		0.5	1	1.5	2	2.5	3
EAN 8-13, UPC-A Code Resolution (mm)	0.25	8	9	11	13	15	18
	0.30	9	10	12	14	16	18
	0.33	9	10	12	14	16	19
	0.38	10	11	13	15	17	19
	0.50	12	13	14	16	19	21
	0.72	16	18	19	20	21	23
	1.00	22	23	24	25	26	27

Table 5

READING DIAGRAMS

Note: $x = 0$ and $z = 0$ correspond to the edge of the DX8200A scanner as shown in the figure below.

DX8200A-3X3X (0.25 mm/10 mils)

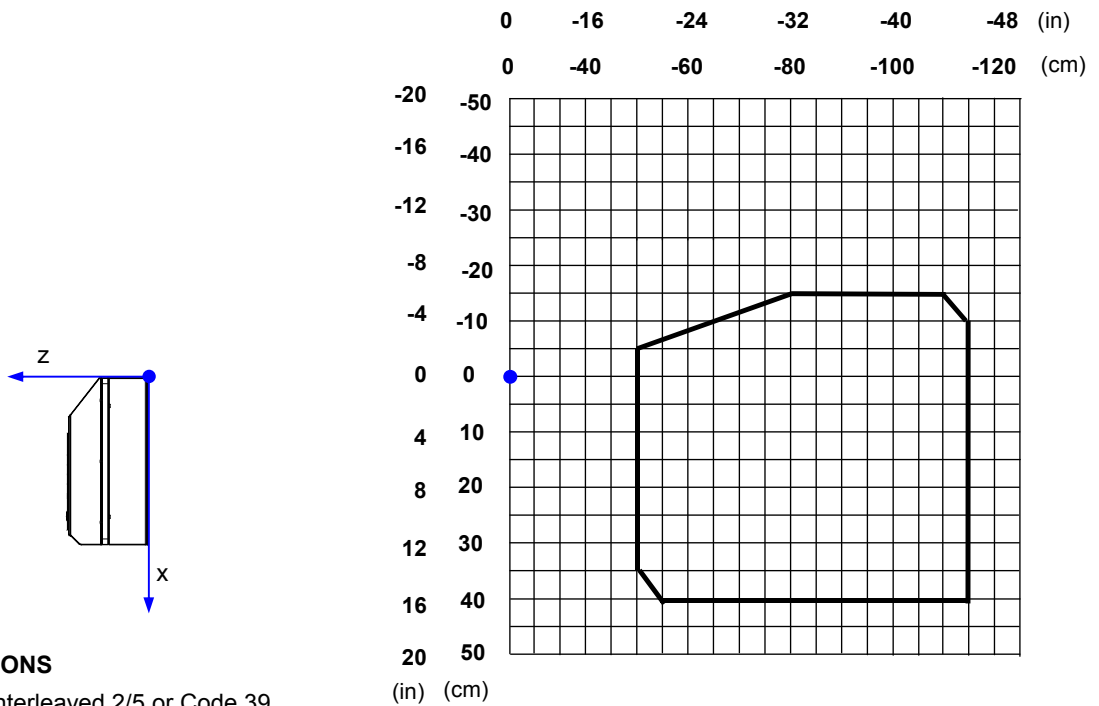

CONDITIONS

Code = Interleaved 2/5 or Code 39
 PCS = 0.90

DX8200A-3X2X (0.30 mm/12 mils)

0 -16 -24 -32 -40 -48 -56 (in)
 0 -40 -60 -80 -100 -120 -140 (cm)

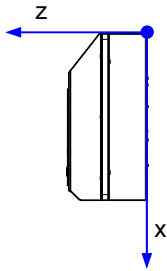

CONDITIONS

Code = Interleaved 2/5 or Code 39
 PCS = 0.90

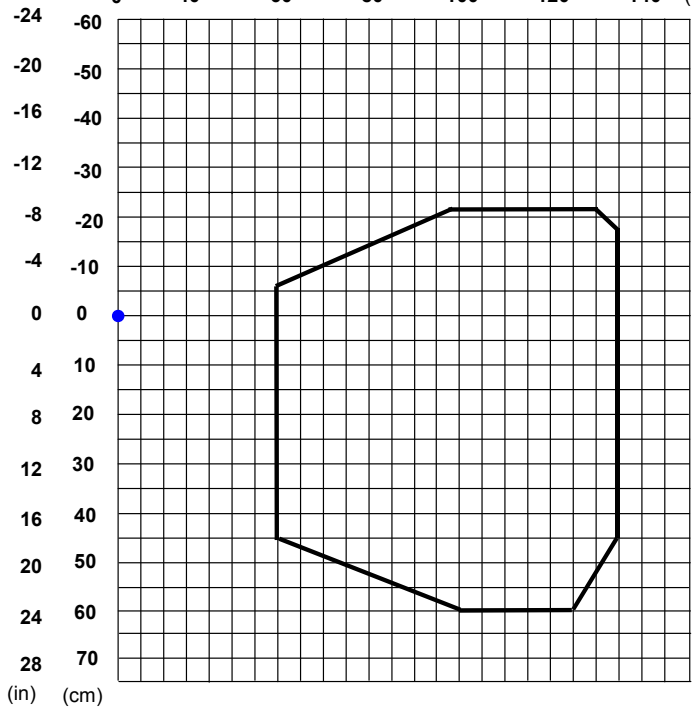

DX8200A-3X1X (0.38 mm/15 mils)

0 -16 -24 -32 -40 -48 -56 -64 (in)
 0 -40 -60 -80 -100 -120 -140 -160 (cm)

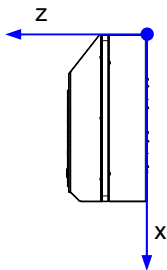

CONDITIONS

Code = Interleaved 2/5 or Code 39
 PCS = 0.90

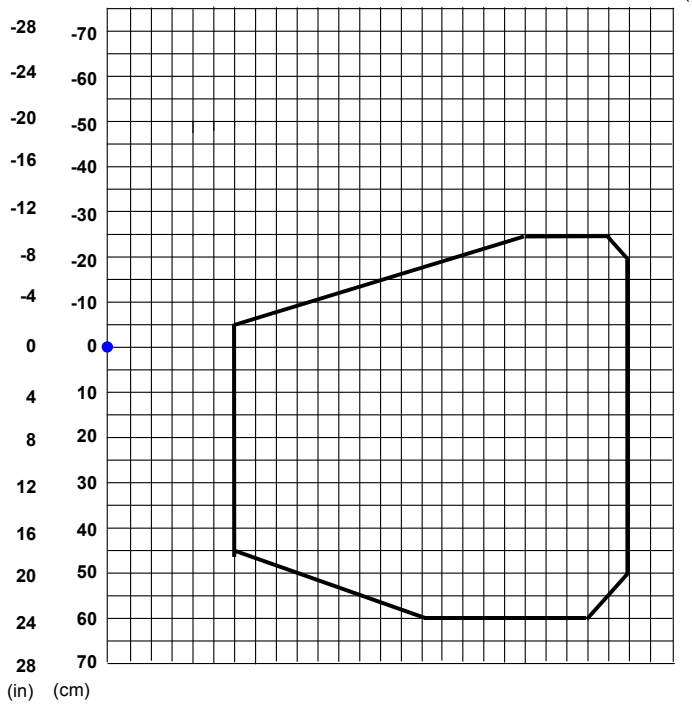

DX8200A-3X1X (0.50 mm/20 mils)

0 -20 -24 -32 -40 -48 -56 -64 -72 (in)
 0 -50 -60 -80 -100 -120 -140 -160 -180 (cm)

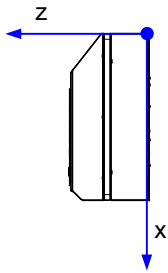

CONDITIONS

Code = Interleaved 2/5 or Code 39
 PCS = 0.90

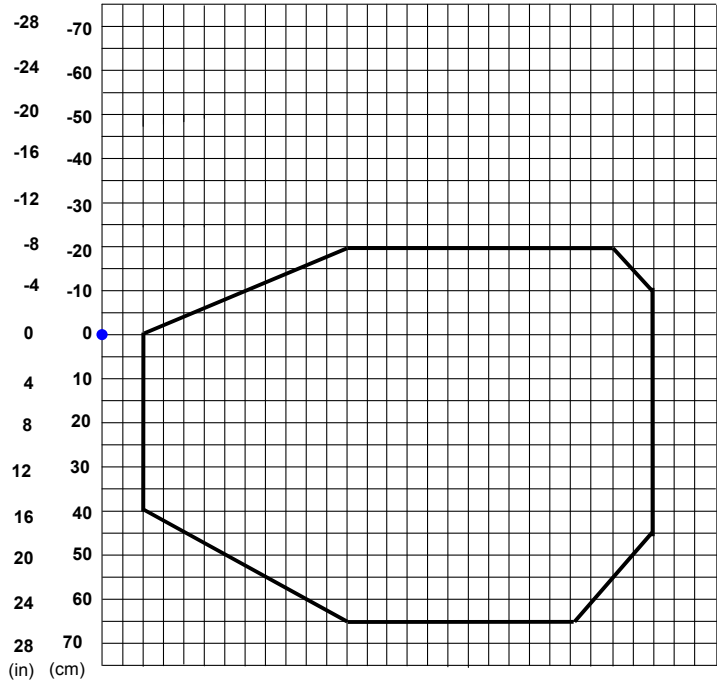

COMPLIANCE

See the DX8200A Reference Manual for the Declaration of Conformity.

LASER SAFETY

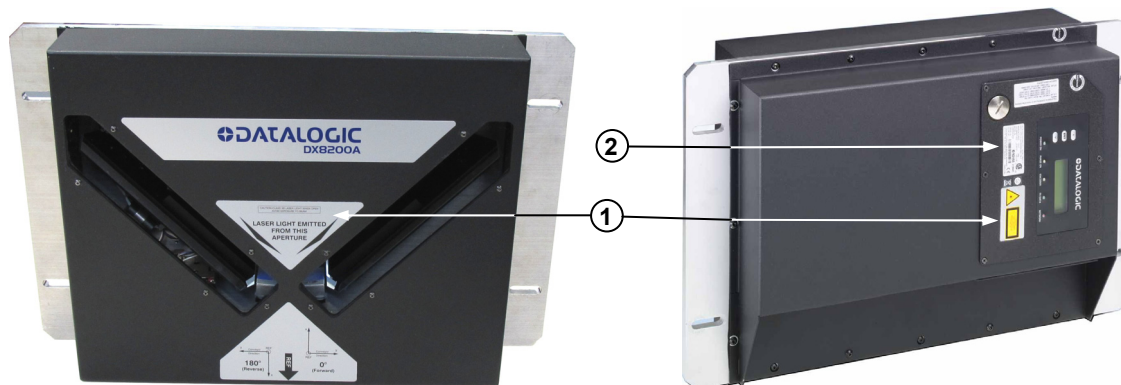

Figure E

- ① Warning and Device Class Label
- ② Device Identification Label

The scanner is classified as a Class 2 laser product according to EN60825-1 regulations and as a Class II laser product according to CDRH regulations.

Disconnect the power supply when opening the device during maintenance or installation to avoid exposure to hazardous laser light.

There is a safety device which allows the laser to be switched on only if the motor is rotating above the threshold for its correct scanning speed.

The laser beam can be switched off through a software command (see also the Genius™ Help On-Line).

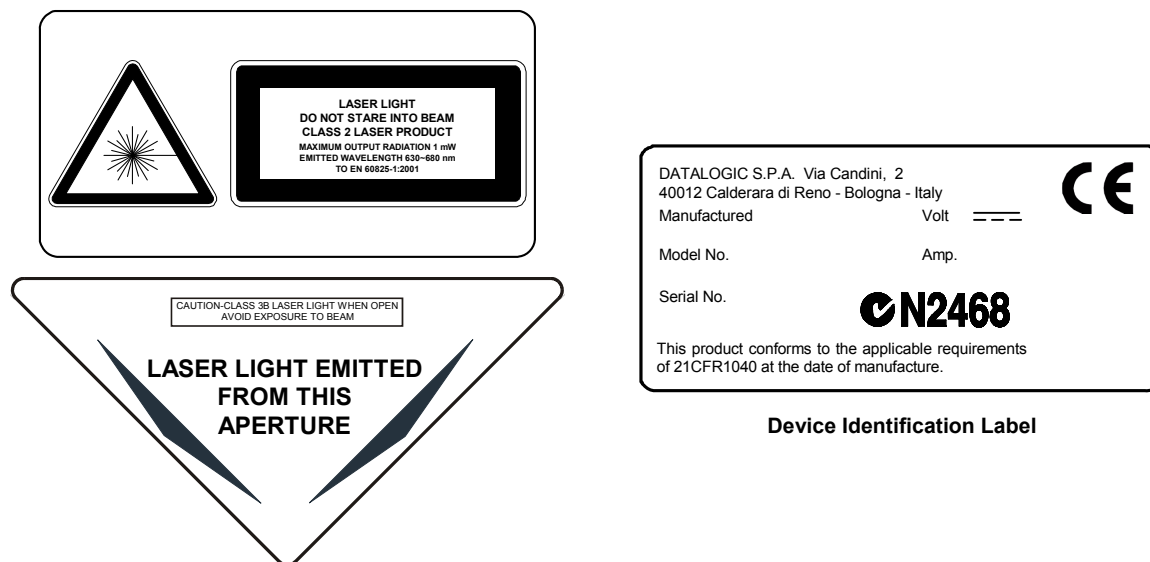

Warning and Device Class Labels

The laser diodes used in this device are classified as Class 3B laser products according to EN 60825-1 regulations and as Class IIIb laser products according to CDRH regulations. Any violation of the optic parts in particular can cause radiation up to the maximum level of the laser diode (30 mW at 630~680 nm).

FCC COMPLIANCE

Modifications or changes to this equipment without the expressed written approval of Datalogic could void the authority to use the equipment.

This device complies with PART 15 of the FCC Rules. Operation is subject to the following two conditions: (1) This device may not cause harmful interference, and (2) this device must accept any interference received, including interference which may cause undesired operation.

This equipment has been tested and found to comply with the limits for a Class A digital device, pursuant to part 15 of the FCC Rules. These limits are designed to provide reasonable protection against harmful interference when the equipment is operated in a commercial environment. This equipment generates, uses, and can radiate radio frequency energy and, if not installed and used in accordance with the instruction manual, may cause harmful interference to radio communications. Operation of this equipment in a residential area is likely to cause harmful interference in which case the user will be required to correct the interference at his own expense.

POWER SUPPLY

This product is intended to be installed by Qualified Personnel only.

For DX8200A VDC models:

- This scanner is intended to be supplied by either a UL Listed power supply marked 'Class 2' or 'LPS', output rated 20 - 30 V dc, minimum 1.75 A or by a UL Listed computer with LPS outputs.
- This scanner must be supplied by a Class II Power Supply Unit conforming to the EN 60950 safety regulation.

Line Fuse Replacement (VAC Models only)

	<p><i>Caution - double pole/neutral fusing.</i> <i>For continued protection against risk of fire, replace with same type and rating of fuse (250V, 3.15 A).</i></p>
<p>CAUTION</p>	

CE COMPLIANCE

Warning:

This is a Class A product. In a domestic environment this product may cause radio interference in which case the user may be required to take adequate measures.

PATENTS

This product is covered by one or more of the following patents.

U.S. patents: Re. 36,251; 5,483,051; 5,992,740; 6,347,740 B1; 6,177,979 B1; 6,394,352 B1; 6,443,360 B1; 6,527,184 B1; 6,629,639 B2; 6,688,524 B1; 6,742,710 B2; 7,161,685 B1; 5,028,772; 5,124,538; 5,466,921; 5,548,107; 6,206,289 B1; 6,669,091 B2; 7,000,838 B2.

European patents: 652,530 B1; 789,315 B1; 851,376 B1; 926,615 B1; 959,426 B9; 1,096,416 B1; 1,217,571 B1; 1,363,228 B1; 1,607,901 B1.

Japanese patents: 3,793,585; 4,033,958; 4,376,353.

Additional patents pending.