



Matrix 200™

QUICK REFERENCE GUIDE

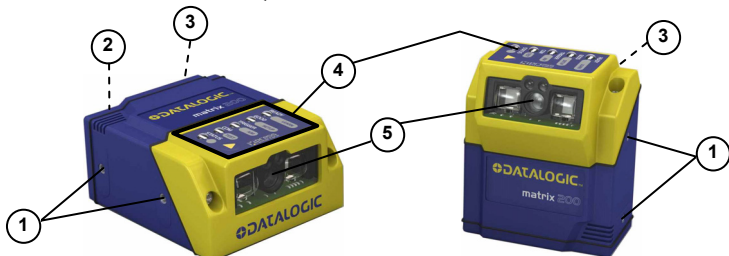

Figure A

- | | | |
|----------------------|--------------------------|------------------|
| ① Mounting Holes (4) | ③ Device Class Labels | ⑤ Reading Window |
| ② "Power ON" LED | ④ HMI X-PRESS™ Interface | |



NOTE

This manual illustrates a Stand Alone application. For other types of installations, such as ID-NET™, Fieldbus, Pass-Through, Multiplexer Layout, etc. and for a complete reader configuration using the VisiSet™ configuration program, refer to the Matrix 200™ Reference Manual available on the CD and also downloadable from the Web at www.automation.datalogic.com.

UPDATES AVAILABILITY

UK/US

The latest drivers and documentation updates for this product are available on Internet.
Log on to: www.automation.datalogic.com

I

Su Internet sono disponibili le versioni aggiornate di driver e documentazione di questo prodotto.
Collegarsi a: www.automation.datalogic.com

F

Les versions mises à jour de drivers et documentation de ce produit sont disponibles sur Internet.
Cliquez sur : www.automation.datalogic.com

D

Im Internet finden Sie die aktuellsten Versionen der Treiber und Dokumentation von diesem Produkt.
Adresse : www.automation.datalogic.com

E

En Internet están disponibles las versiones actualizadas de los drivers y documentación de este producto.
Dirección Internet : www.automation.datalogic.com

SERVICES AND SUPPORT

Datalogic provides several services as well as technical support through its website. Log on to www.automation.datalogic.com and click on the [links](#) indicated for further information:

- **PRODUCTS**

Search through the links to arrive at your product page which describes specific Info, Features, Applications, Models, Accessories, and Downloads including the [VisiSet™](#) utility program, which allows device configuration using a PC. It provides RS232 and Ethernet interface configuration.

- **SERVICE**

- **Overview** - Warranty Extensions and Maintenance Agreements
- **Sales Network**- Listing of Subsidiaries, Repair Centers, Partners
- **Helpdesk**
- **Material Return Authorization**

LEGAL NOTICES

© 2007 – 2010 Datalogic Automation S.r.l. ♦ ALL RIGHTS RESERVED. ♦ Protected to the fullest extent under U.S. and international laws. Copying, or altering of this document is prohibited without express written consent from Datalogic Automation S.r.l.

Datalogic and the Datalogic logo are registered trademarks of Datalogic S.p.A. in many countries, including the U.S.A. and the E.U.

Matrix 200, ID-NET, VisiSet and X-PRESS are trademarks of Datalogic Automation S.r.l. All other brand and product names mentioned herein are for identification purposes only and may be trademarks or registered trademarks of their respective owners.

Datalogic shall not be liable for technical or editorial errors or omissions contained herein, nor for incidental or consequential damages resulting from the use of this material.

STEP 1 – CONNECT THE SYSTEM

25-Pin Models

To connect the system in a Stand Alone configuration, you need the hardware indicated in Figure 1. In this layout the data is transmitted to the Host on the main serial interface. Data can also be transmitted on the RS232 auxiliary interface independently from the main interface selection. When One Shot or Phase Mode Operating mode is used, the reader is activated by an External Trigger (photoelectric sensor) when the object enters its reading zone.

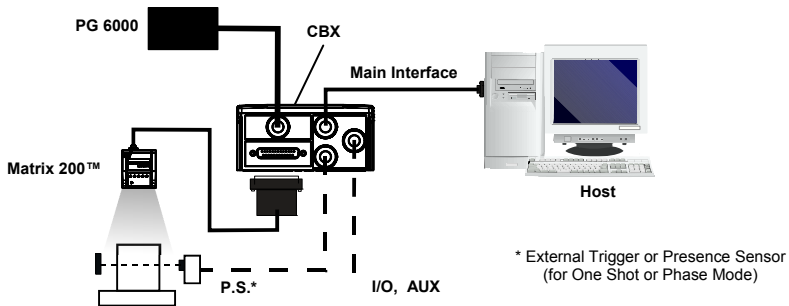

Figure 1 – Matrix 200™ 25-Pin Model in a Stand Alone Layout

CBX100/CBX500 Pinout for Matrix 200™ 25-Pin Models

The table below gives the pinout of the CBX100/CBX500 terminal block connectors. Use this pinout when the Matrix 200™ reader is connected by means of the CBX100/CBX500:

CBX100/500 Terminal Block Connectors			
Power		Outputs	
Vdc	Power Supply Input Voltage +	+V	Power Source - Outputs
GND	Power Supply Input Voltage -	-V	Power Reference - Outputs
Earth	Protection Earth Ground	O1+	Output 1 +
		O1-	Output 1 -
Inputs		O2+	Output 2 +
+V	Power Source – External Trigger	O2-	Output 2 -
I1A	External Trigger A (polarity insensitive)	Auxiliary Interface	
I1B	External Trigger B (polarity insensitive)	TX	Auxiliary Interface TX
-V	Power Reference – External Trigger	RX	Auxiliary Interface RX
+V	Power Source – Inputs	SGND	Auxiliary Interface Reference
I2A	Input 2 A (polarity insensitive)	ID-NET™	
I2B	Input 2 B (polarity insensitive)	REF	Network Reference
-V	Power Reference – Inputs	ID+	ID-NET™ network +
Shield		ID-	ID-NET™ network -
Shield	Network Cable Shield		
Main Interface			
	RS232	RS485 Full-Duplex	RS485 Half-Duplex
	TX	TX+	RTX+
	RTS	TX-	RTX-
	RX	* RX+	
	CTS	* RX-	
	SGND	SGND	SGND

* Do not leave floating, see Reference Manual for connection details.



CAUTION

Do not connect GND, SGND and REF to different (external) ground references. GND, SGND and REF are internally connected through filtering circuitry which can be permanently damaged if subjected to voltage drops over 0.8 Vdc.

25-Pin Connector Pinout for Matrix 200™ 25-Pin Models

The table below gives the pinout of the 25-pin male D-sub connector for connection to the power supply and input/output signals. Use this pinout when the Matrix 200™ reader is connected by means of the 25-pin connector:

25-pin D-sub male connector pinout				
Pin	Name	Function		
13, 9	Vdc	Power supply input voltage +		
25, 7	GND	Power supply input voltage -		
1	CHASSIS	Cable shield connected to chassis		
18	I1A	External Trigger A (polarity insensitive)		
19	I1B	External Trigger B (polarity insensitive)		
6	I2A	Input 2 A (polarity insensitive)		
10	I2B	Input 2 B (polarity insensitive)		
8	O1+	Output 1 +		
22	O1-	Output 1 -		
11	O2+	Output 2 +		
12	O2-	Output 2 -		
20	RX	Auxiliary RS232 RX		
21	TX	Auxiliary RS232 TX		
23	ID+	ID-NET™ network +		
24	ID-	ID-NET™ network -		
14, 15, 16, 17	NC	Not Connected		
Pin	Name	RS232	RS485 Full-Duplex	RS485 Half-Duplex
2	MAIN INTERFACE (SW SELECTABLE)	TX	TX+	RTX+
3		RX	*RX+	
4		RTS	TX-	RTX-
5		CTS	*RX-	

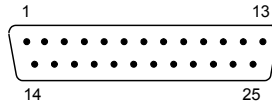

Figure 2 - 25-pin Male D-sub Connector

* Do not leave floating, see Reference Manual for connection details.

USB Models

**NOTE**

Before connecting the reader to the USB Port, install the USB Virtual COM Port Driver from the Support Files\USB Virtual COM Port Drivers directory on the VisiSet CD-ROM.

The USB Virtual COM Port Driver allows sending serial data using the Matrix 200™ USB port. A different virtual COM Port will be assigned to each connected reader.

Installing the USB Virtual COM port drivers:

1. Double-click on the following file to launch the USB Virtual COM Port Driver Installer.

Windows XP = "DPInst.exe"

Windows Vista = "DPInst64.exe"

For other operating systems see the readme.txt in the Support Files\USB Virtual COM Port Drivers directory. For updated drivers or more details go to ftdichip.com/Drivers/VCP.htm.

Configuring the USB Virtual COM port:

Connect the Matrix 200™ USB reader to your PC; a new virtual COM port is associated with the reader. Follow these steps to configure the associated COM Port:

2. Right-click on "My Computer" in the Windows "Start" menu and select "Properties".
3. Select the "Hardware" tab in the System Properties dialog and click the "Device Manager" button.
4. Expand the "Ports (COM & LPT)" item on the "Device Manager" menu. Right-click on "USB Serial Port" and select "Properties".
5. Select the "Port Settings" tab in the "Properties" dialog and click the "Advanced" button.

6. From the "Advanced Settings for COMx" dialog:

- Expand the "COM Port Number" menu and select a new COM Port number if desired (optional).
- Set the "BM Options" -> "Latency Timer" (msec) parameter to 1.

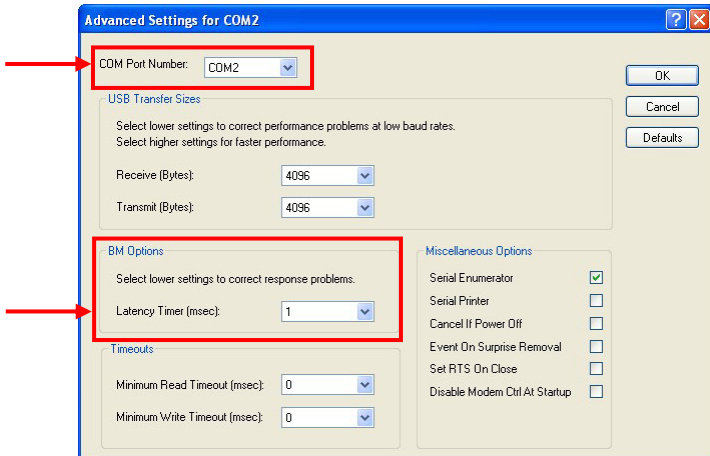

You are now ready to use the new COM Port.

Matrix 200™ USB models can be connected in a Point-to-Point layout to a local host through their USB cable. No external power supply is necessary.

The default baud rate is 115200. To maximize data transfer you can set it up to 921600 by configuring the reader though the Communication parameters via VisiSet™. For further details, see the Communication Folder in the VisiSet™ Help On Line.

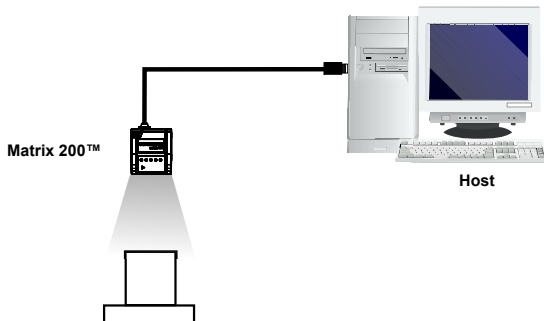

Figure 3 – Matrix 200™ USB Model in a Point-to-Point Layout

STEP 2 – MOUNT AND POSITION THE READER

- To mount the Matrix 200™, use the mounting bracket to obtain the most suitable position for the reader. Two of the most common mounting configurations are shown in the figures below. Other mounting solutions are provided in the Matrix 200™ Reference Manual.

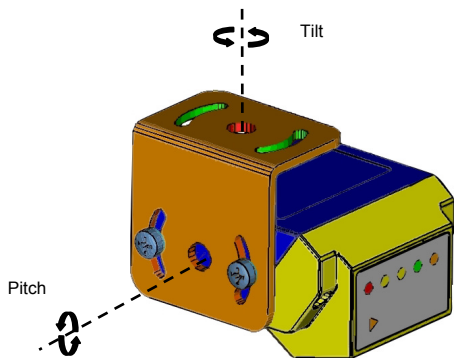

Figure 4 –Positioning 90° Model with Mounting Bracket

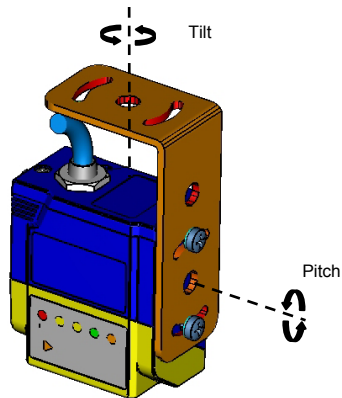

Figure 5 –Positioning Straight Model with Mounting Bracket

2. When mounting the Matrix 200™ take into consideration these three ideal label position angles: **Pitch or Skew 10° to 20° and Tilt 0°**, although the reader can read a code at any tilt angle.

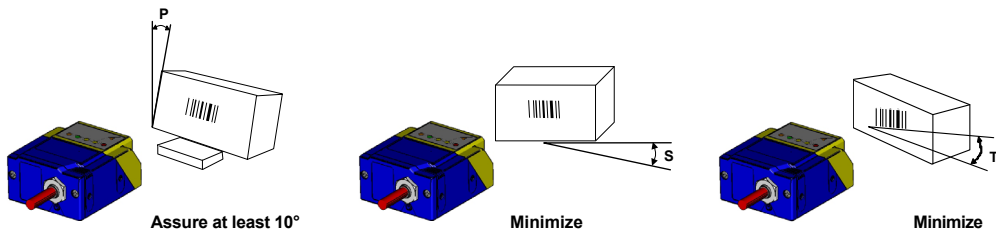

Figure 6 – Pitch, Skew and Tilt Angles

3. Refer to the Reading Features table in the Appendix of this Quick Reference Guide to determine the distance your reader should be positioned at.



NOTE

Rapid Configuration of the Matrix 200™ reader can be made **either** through the X-PRESS™ interface (steps 3-4) which requires no PC connection, **or** by using the VisiSet™ Setup Wizard (steps 5-6). Select the procedure according to your needs.

STEP 3 – AIM THE READER

Matrix 200™ provides a built-in aiming system to aid reader positioning. The aiming system is accessed through the X-PRESS™ Interface.

1. Power the reader on. During the reader startup (reset or restart phase), all the LEDs blink for one second. On the connector side of the reader near the cable, the “POWER ON” LED (blue) indicates the reader is correctly powered.
2. Enter the Aim/Locate function by pressing and holding the X-PRESS™ push button until the Aim LED is on.
3. Release the button to enter the Aim function. The aiming system turns on see Figure 7.
4. Place the application specific code in front of the reader at the reading distance indicated for your model in the Reading Features table, centering it in the aiming system indicator.

default value for:
NEAR, MEDIUM,
FAR models

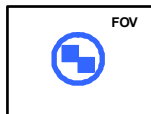

default value for:
UHD models

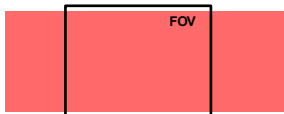

Figure 7 – Aiming Function Using The Blue Ring or Internal Lighting System *

* the default value of the Aiming System Status parameter can be changed in VisiSet™.



Figure 8 – X-PRESS™ Interface:
Aim Function

5. Exit the Aim function by pressing the X-PRESS™ push button once. The aiming system turns off.

STEP 4 – X-PRESS™ CONFIGURATION

Once Matrix 200™ is positioned with respect to the code (step 3), you can configure it for optimal code reading relative to your application. This configuration can be performed either through the X-PRESS™ Interface or the VisiSet™ configuration program.

SETUP

1. Enter the Setup function by pressing and holding the X-PRESS™ push button until the Setup LED is on.
2. Release the button to enter the Setup function. The Setup LED will blink until the procedure is completed.

The Setup procedure ends when the Image Acquisition parameters are successfully saved in the reader memory, the Setup LED will remain on continuously and Matrix 200™ emits 3 high pitched beeps.

If the calibration cannot be reached after a timeout of about 5 (five) seconds Matrix 200™ will exit without saving the parameters to memory, the Setup LED will not remain on continuously but it will just stop blinking. In this case Matrix 200™ emits a long low pitched beep.

3. Exit the Setup function by pressing the X-PRESS™ push button once.

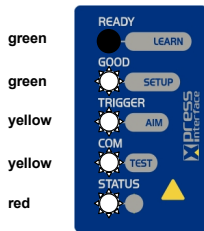

Figure 9 – X-PRESS™ Interface:
Setup Function

LEARN

4. Enter the Learn function by pressing and holding the X-PRESS™ push button until the Learn LED is on.
5. Release the button to enter the Learn function. The Learn LED will blink until the procedure is completed.

The Learn procedure ends when the Image Processing and Decoding parameters are successfully saved in the reader memory, the Learn LED will remain on continuously, the Green Spot is activated and Matrix 200™ emits 3 high pitched beeps¹.

If the calibration cannot be reached after a timeout of about 3 (three) minutes Matrix 200™ will exit without saving the parameters to memory, the Learn LED will not remain on continuously but it will just stop blinking. In this case Matrix 200™ emits a long low pitched beep.

6. Exit the Setup function by pressing the X-PRESS™ push button once.

If you have used this procedure to configure Matrix 200™ go to step 7.

RESET READER TO FACTORY DEFAULT (OPTIONAL)

If it ever becomes necessary to reset the reader to the factory default values, you can perform this procedure by holding the X-PRESS™ push button pressed while powering up the reader. **You must keep the X-PRESS™ push button pressed until the power up sequence is completed** (several seconds) and all LEDs blink simultaneously 3 times.

All LEDs remain on for about 1 second, then off for one second, the Configuration and Environmental parameters are reset, and the status LED remains on. If connected through a CBX500 with display module, the message "Default Set" is shown on the display.

¹ The Learn procedure will not recognize Pharmacode symbologies.

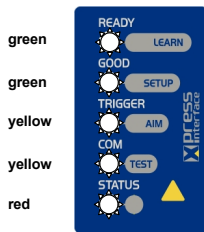

Figure 10 – X-PRESS™ Interface:
Learn Function

STEP 5 – INSTALLING VISISET™ CONFIGURATION PROGRAM

VisiSet™ is a Datalogic reader configuration tool providing several important advantages:

- Setup Wizard for rapid configuration and new users;
- Defined configuration directly stored in the reader;
- Communication protocol independent from the physical interface allowing to consider the reader as a remote object to be configured and monitored.

To install VisiSet™, turn on the PC that will be used for the configuration, running Windows 98, 2000/NT, XP or Vista, then insert the VisiSet™ CD-ROM, wait for the CD to autorun and follow the installation procedure.

This configuration procedure assumes a laptop computer, running VisiSet™, is connected to the reader's auxiliary port.

After installing and running the VisiSet™ software program the following window appears:

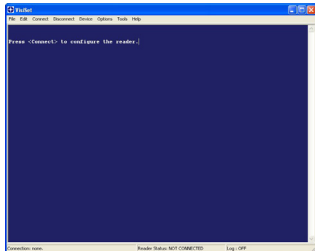

Figure 11 - VisiSet™ Opening Window

Set the communication parameters from the "Options" menu. Then select "Connect", the following window appears:

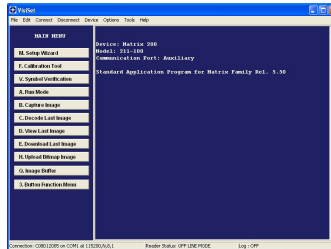
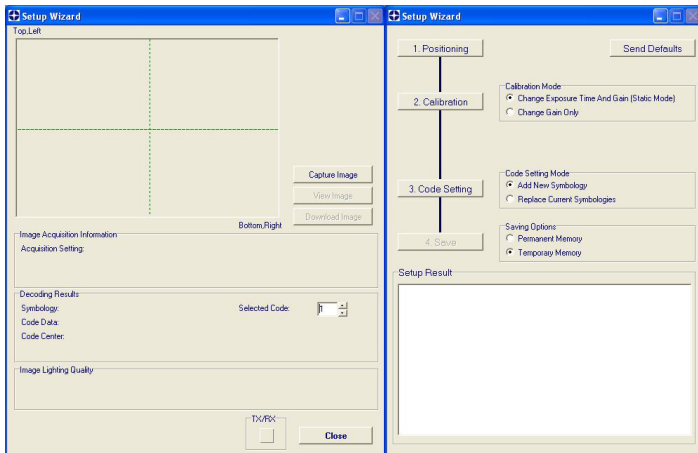

Figure 12 - VisiSet™ Main Window After Connection

STEP 6 – CONFIGURATION USING SETUP WIZARD

The Setup Wizard option is advised for rapid configuration or for new users. It allows reader configuration in a few easy steps.

1. Select the Setup Wizard button from the Main menu.



Place the application specific code in front of the reader at the correct reading distance (see step 2 and the Reading Features table in the Appendix of this Quick Reference Guide).

2. Press the "Positioning" button. The reader continuously acquires images and gives visual feedback in the view image window. Move the reader (or code) to center it. Press the Positioning button again to stop positioning.

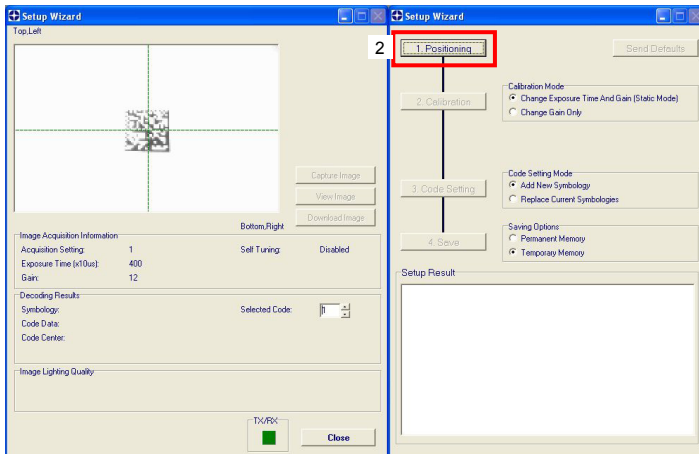

3. Select a Calibration Mode choice and press the "Calibrate" button. The reader flashes once acquiring the image and auto determines the best exposure and gain settings. If the code symbology is enabled by default, the code will also be decoded.

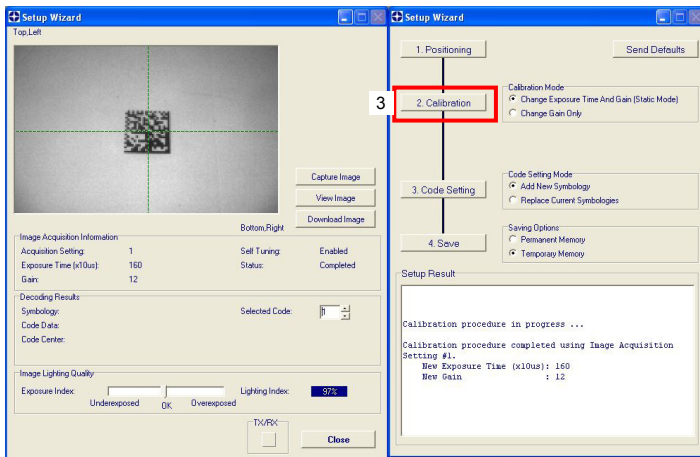

4. Select a Code Setting Mode choice and press the "Code Setting" button.

The Setup Result section of the Setup Wizard window shows the code type results and parameter settings.

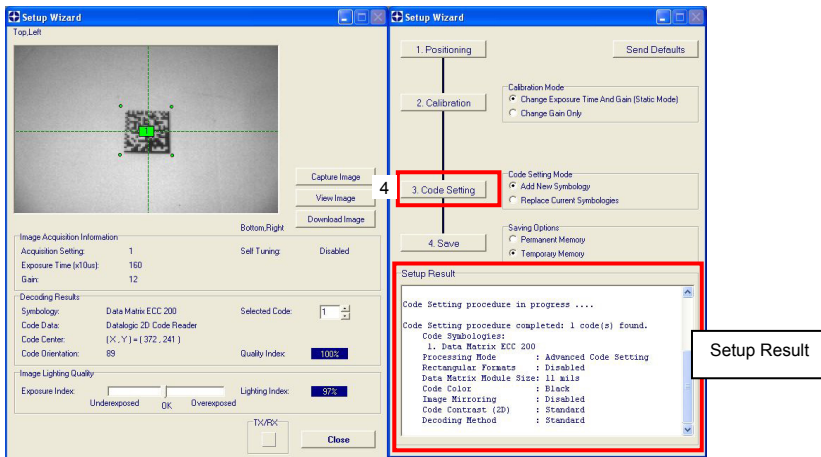

5. Select a Saving Options choice and press the "Save" button.

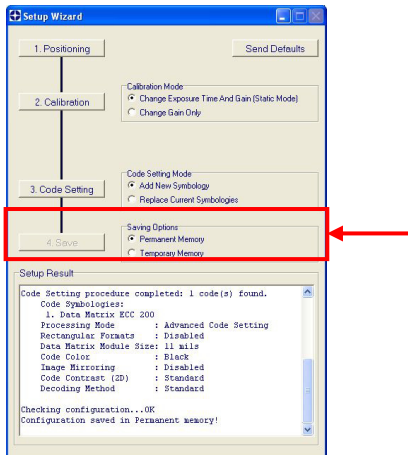

6. Close the Setup Wizard.



NOTE

If your application has been configured using the VisiSet™ Setup Wizard, your reader is ready. If necessary you can use VisiSet™ for advanced reader configuration.

STEP 7 – TEST MODE

Use a code suitable to your application to test the reading performance of the system. Alternatively, you can use the Datalogic 1D/2D Test Chart (Code 39, Data Matrix ECC 200).

1. Enter the *Test* function by pressing and holding the X-PRESS™ push button until the Test LED is on.
2. Release the button to enter the *Test* function.

Once entered, the Bar Graph on the five LEDs is activated and if the reader starts reading codes the Bar-Graph shows the Good Read Rate. In case of no read condition, only the STATUS LED is on and blinks.

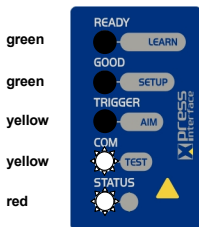

Figure 13 - X-PRESS™ Interface: Test Function

The Bar Graph has the following meaning:

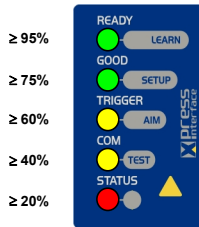

Figure 14 – Test Bar Graph

3. To exit the Test, press the X-PRESS™ push button once.



NOTE

By default, the Test exits automatically after three minutes.

ADVANCED READER CONFIGURATION

For further details on advanced product configuration, refer to the complete Reference Manual on the installation CD-ROM or downloadable from the web site through this link: www.automation.datalogic.com.

The following are alternative or advanced reader configuration methods.

ADVANCED CONFIGURATION USING VISISET™

Advanced configuration can be performed through the VisiSet™ program by selecting *Device> Get Configuration From Temporary Memory* to open the Parameter Setup window in off-line mode. Advanced configuration is addressed to expert users being able to complete a detailed reader configuration. The desired parameters can be defined in the various folders of the Parameter Setup window and then sent to the reader memory (either Temporary or Permanent):

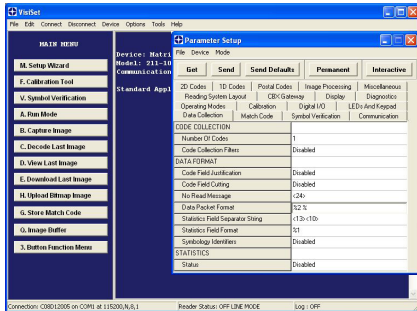

Figure 15 - VisiSet™ Parameter Setup Window

HOST MODE PROGRAMMING

The reader can also be configured from a host computer using the Host Mode programming procedure, by commands via the serial interface. See the Host Mode Programming file on the CD-ROM.

ALTERNATIVE LAYOUTS

(for 25-pin models)

If you need to install an ID-NET™ network, Fieldbus network, Pass-Through network, Multiplexer network or an RS232 Master/Slave refer to the Matrix 200™ Reference Manual.

The reader can also be setup for alternative layouts by reading programming barcodes. See the "Setup Procedure Using Programming Barcodes" printable from the CD-ROM.

CODE QUALITY VERIFICATION

Matrix 200™ can be used as a Code Quality Verifier according to the ISO/IEC 15415, ISO/IEC 15416, AS9132, and AIM DPM Standards.

APPENDIX

X-PRESS™ is the intuitive Human Machine Interface designed to improve ease of installation and maintenance.

Status and diagnostic information are clearly presented by means of the five colored LEDs, whereas the single push button gives immediate access to the following relevant functions:

- *Learn* to self-detect and auto-configure for reading unknown codes
- *Setup* to perform Exposure Time and Gain calibration.
- *Aim/Locate* to turn on the blue ring to aid positioning.
- *Test* with bar graph visualization to check static reading performance

In normal operating mode the colors and meaning of the five LEDs are illustrated in the following table:

READY (green)	This LED indicates the device is ready to operate.
GOOD (green)	This LED confirms successful reading.
TRIGGER (yellow)	This LED indicates the status of the reading phase.
COM (yellow)	This LED indicates active communication on main serial port.
STATUS (red)	This LED indicates a NO READ result.

During the reader startup (reset or restart phase), all the LEDs blink for one second.

On the connector side of the reader near the cable, the blue POWER ON LED indicates the reader is correctly powered.



Figure 16 – Power LED



READING FEATURES

MODELS	Focus Distance mm (in)	Field of View ⁽¹⁾ mm (in)	PPI ⁽²⁾	Typ. Linear and Stacked Code Resolution mm (mils)	2D Code Resolution mm (mils)		Reading Distance ⁽³⁾ mm (in)	
							min.	max.
214-xxx UHD	30 (1.18)	16.5 × 10.5 (0.65 × 0.41)	1150	0.063 (2.5)	Max.	0.076 (3)	28 (1.10)	32 (1.26)
					Typ.	0.13 (5)	23 (0.91)	38 (1.50)
211-xxx NEAR	45 (1.77)	35 × 22 (1.38 × 0.87)	545	0.10 (4)	Max.	0.13 (5)	42 (1.65)	53 (2.08)
					Typ.	0.19 (7.5)	36 (1.42)	61 (2.40)
212-xxx MEDIUM	65 (2.56)	50 × 32 (1.97 × 1.26)	380	0.15 (6)	Max.	0.19 (7.5)	54 (2.13)	90 (3.54)
					Typ.	0.25 (10)	47 (1.85)	101 (3.97)
213-xxx FAR	105 (4.13)	80 × 50 (3.15 × 1.97)	238	0.20 (8)	Max.	0.25 (10)	85 (3.35)	135 (5.31)
					Typ.	0.38 (15)	70 (2.76)	192 (7.55)

⁽¹⁾ @ Focus Distance

⁽²⁾ Pixels per inch @ Focus Distance

⁽³⁾ Measurement Conditions:

- Test Chart: provided with the reader
- Still code at the center of the FOV
- Code Symbology: Data Matrix ECC 200
- Tilt Angle: 45°
- Skew Angle: 15°
- Image Processing Mode = Advanced Code Setting
- Module Size (mils) equal to the resolution of the code to read
- Image Processing Self Tuning = Enabled
- Image Processing Self Tuning Mode = Code Contrast Levels Only *
- Image Acquisition Self Tuning = Enabled (for 213-xxx models only)

* This parameter setting can increase the image processing time.

All distances are measured from the reading window to the code surface.

Depending on the code resolution, symbology and number of characters in the code, the Reading Area can be different from the FOV.

TECHNICAL FEATURES

ELECTRICAL FEATURES	Matrix 200 21x-x0x models	Matrix 200 21x-x2x models
Power Supply Voltage Consumption	10 to 30 Vdc 0.32 to 0.12 A, 3.6 W max. 0.29 to 0.10 A; 3.0 W typ.	5 Vdc 0.5 A, 2.5 W max. 0.4 A; 2.0 W typ.
Communication Interfaces Main - RS232 - RS485 full-duplex - RS485 half-duplex	2400 to 115200 bit/s 2400 to 115200 bit/s 2400 to 115200 bit/s	USB 2.0 up to 921600 bit/s
Auxiliary - RS232	2400 to 115200 bit/s	
ID-NET™	Up to 1MBaud	
Inputs Input 1(External Trigger) and Input 2	Opto-coupled and polarity insensitive	
Outputs Output 1 and Output 2	Opto-coupled	
OPTICAL FEATURES		
Image Sensor	CMOS sensor with Global Shutter	
Image Format	WVGA (752x480)	
Frame Rate	up to 60 frames/sec. @ full window size	
Pitch	± 35°	
Tilt	0° - 360°	
Lighting System	Internal Illuminator	
LED Safety Class	Class 1 to EN60825-1	
PHYSICAL FEATURES	Matrix 200 21x-1xx models	Matrix 200 21x-0xx models
Dimensions	50 x 25 x 45 mm (1.97 x 0.98 x 1.77 in)	54 x 32 x 45 mm (2.13 x 1.26 x 1.77 in)
Weight	60 g. (2.1 oz.) without cable	
Material	Aluminium alloy	

ENVIRONMENTAL FEATURES		
Operating Temperature *	0 to 50 °C (32 to 122 °F)	
Storage Temperature	-20 to 70 °C (-4 to 158 °F)	
Max. Humidity	90% non condensing	
Vibration Resistance EN 60068-2-6	14 mm @ 2 to 10 Hz; 1.5 mm @ 13 to 55 Hz; 2 g @ 70 to 200 Hz; 2 hours on each axis	
Bump Resistance EN 60068-2-29	30g; 6 ms; 5000 shocks on each axis	
Shock Resistance EN 60068-2-27	30g; 11 ms; 3 shocks on each axis	
Protection Class	EN 60529	IP65
SOFTWARE FEATURES		
Readable Code Symbologies		
1-D and stacked	2-D	POSTAL
<ul style="list-style-type: none"> • PDF417 Standard and Micro PDF417 • Code 128 (EAN 128) • Code 39 (Standard and Full ASCII) • Code 32 • MSI • Standard 2 of 5 • Matrix 2 of 5 • Interleaved 2 of 5 • Codabar • Code 93 • Pharmacode • EAN-8/13 - UPC-A/E (including Addon 2 and Addon 5) • GS1 DataBar Family • Composite Symbologies 	<ul style="list-style-type: none"> • Data Matrix ECC 200 (Standard, GS1 and Direct Marking) • QR Code (Standard and Direct Marking) • Micro QR Code • MAXICODE • Aztec Code • Microglyph (this symbology requires an activation procedure – contact your local Datalogic Automation distributor for details) 	<ul style="list-style-type: none"> • Australia Post • Royal Mail 4 State Customer • Kix Code • Japan Post • PLANET • POSTNET • POSTNET (+BB) • Intelligent Mail • Swedish Post
Operating Mode	ONE SHOT, CONTINUOUS, PHASE MODE	
Configuration Methods	X-PRESS™ Human Machine Interface Windows-based SW (VisiSet™) via serial or USB link Serial Host Mode Programming sequences	
Parameter Storage	Permanent memory (Flash)	

* high ambient temperature applications should use metal mounting bracket for heat dissipation.

CODE QUALITY VERIFICATION	
Standard	Supported Symbolologies
ISO/IEC 16022	Data Matrix ECC 200
ISO/IEC 18004	QR Code
ISO/IEC 15415	Data Matrix ECC 200, QR Code
ISO/IEC 15416	Code 128, Code 39, Interleaved 2 of 5, Codabar, Code 93, EAN-8/13, UPC-A/E
AS9132A	Data Matrix ECC 200
AIM DPM	Data Matrix ECC 200, QR Code
USER INTERFACE	
LED Indicators	Power, Ready, Good; Trigger; Com, Status; (Green Spot)
Other	Keypad Button (configurable via VisiSet™); Beeper

MECHANICAL DIMENSIONS

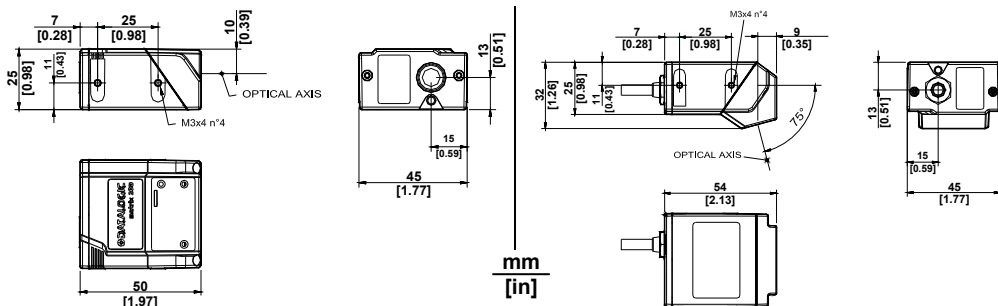
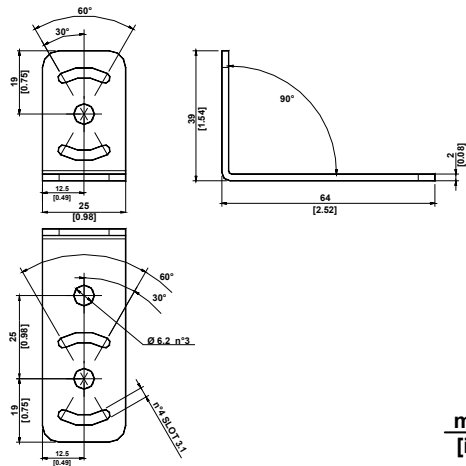
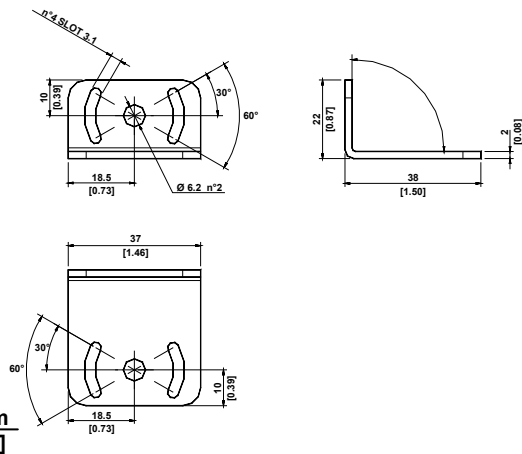

Figure 17 – Matrix 200™ Overall Dimensions - Straight and 90° Reading Window Models

ST-336 bracket for Straight Reading Window Model



ST-337 bracket for 90° Reading Window Model



mm
[in]

Figure 18 – Mounting Brackets Overall Dimensions

PATENTS

This product is covered by one or more of the following patents:

U.S. patents: 6,512,218 B1; 6,616,039 B1; 6,808,114 B1; 6,997,385 B2; 7,102,116 B2; 7,282,688 B2

European patents: 999,514 B1; 1,014,292 B1; 1,128,315 B1.

Additional patents pending.

COMPLIANCE

See the Matrix 200™ Reference Manual for the Declaration of Conformity.

EMC COMPLIANCE

In order to meet the EMC requirements:

- connect reader chassis to the plant earth ground by means of a flat copper braid shorter than 100 mm;
- connect pin "Earth" of the CBX connection box to a good Earth Ground;
- for direct connections, connect the main interface cable shield to pin 1 of the 25-pin connector.

POWER SUPPLY

This product is intended to be installed by Qualified Personnel only.

This product is intended to be connected to a UL Listed Computer which supplies power directly to the reader or a UL Listed Direct Plug-in Power Unit marked LPS or "Class 2", rated 10 to 30 V, minimum 500 mA.

CE COMPLIANCE

Warning: This is a Class A product. In a domestic environment this product may cause radio interference in which case the user may be required to take adequate measures.

FCC COMPLIANCE

Modifications or changes to this equipment without the expressed written approval of Datalogic could void the authority to use the equipment.

This device complies with PART 15 of the FCC Rules. Operation is subject to the following two conditions: (1) This device may not cause harmful interference, and (2) this device must accept any interference received, including interference which may cause undesired operation.

This equipment has been tested and found to comply with the limits for a Class A digital device, pursuant to part 15 of the FCC Rules. These limits are designed to provide reasonable protection against harmful interference when the equipment is operated in a commercial environment. This equipment generates, uses, and can radiate radio frequency energy and, if not installed and used in accordance with the instruction manual, may cause harmful interference to radio communications. Operation of this equipment in a residential area is likely to cause harmful interference in which case the user will be required to correct the interference at his own expense.