

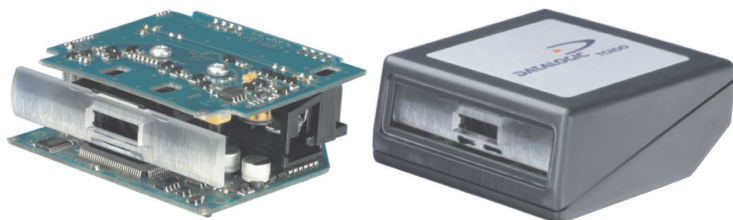

TC1100



Reference Manual



Datalogic Automation S.r.l.
Via S. Vitalino 13
40012 - Lippo di Calderara di Reno
Bologna - Italy

TC1100 Reference Manual

Ed.: 10/2007

ALL RIGHTS RESERVED

Datalogic reserves the right to make modifications and improvements without prior notification.

Datalogic shall not be liable for technical or editorial errors or omissions contained herein, nor for incidental or consequential damages resulting from the use of this material.

Product names mentioned herein are for identification purposes only and may be trademarks and or registered trademarks of their respective companies.

© Datalogic Automation S.r.l. 2000-2007

821000703 (Rev. C)

CONTENTS

1	INTRODUCTION	1
1.1	Configuration Methods	1
1.1.1	Configuration for RS232 Interface Users	1
1.1.2	Configuration for Wedge Interface Users	1
1.2	Status Indicators	2
1.3	Available Models	3
2	INSTALLATION.....	4
2.1	TC1100 CCD Scanner	4
2.1.1	Mechanical Installation	4
2.1.2	Electrical Connections	5
	RS232 Interface	6
	WEDGE Interface	6
	PEN Emulation Interface	7
	Inputs	7
	Outputs	8
	External Beeper Connection	9
2.2	TC1100 CCD Scan Engine	10
2.2.1	Mechanical Installation	10
2.2.2	Electrical Connections	11
	RS232 Interface	12
	WEDGE Interface	12
	PEN Emulation Interface	13
	Inputs	13
	Outputs	14
	External Beeper Connection	15
2.3	Positioning	16
2.4	GFC-TC1100 Accessory	17
3	SOFTWARE CONFIGURATION STRINGS	20
3.1	Default Configuration	20
3.2	TC1100 Configuration	22
	Command Syntax	23
4	BARCODE CONFIGURATION.....	34
4.1	Initial Setup	34
	Restore Default	34
	Interface Selection	34
4.2	Changing Default Settings	39
	RS232 PARAMETERS	40
	Baud Rate	41

Parity.....	42
Data Bits.....	42
Stop Bits.....	43
Handshaking.....	43
ACK/NACK Protocol.....	44
FIFO.....	44
Inter-Character Delay.....	45
Rx Timeout.....	45
WEDGE PARAMETERS	46
Keyboard Nationality.....	47
Caps Lock.....	48
Num Lock.....	48
Inter-Character Delay.....	49
Inter-Code Delay.....	49
Keyboard Setting.....	50
Control Character Emulation.....	52
PEN EMULATION	53
Operating Mode.....	54
Minimum Output Pulse.....	55
Conversion To Code 39.....	56
Overflow.....	57
Output Level.....	57
Idle Level.....	58
Inter-Block Delay.....	58
DATA FORMAT.....	59
Code Identifier.....	62
Custom Code Identifier.....	63
Header.....	64
Terminator.....	65
Field Adjustment.....	66
Field Adjustment Character.....	67
Code Length Tx.....	67
Character Replacement.....	68
No Read Character.....	70
POWER SAVE.....	71
Read Rate.....	72
Sleep State.....	72
Enter Sleep Timeout.....	73
Standby.....	73
READING PARAMETERS	74
Operating Mode.....	75
Beeper Intensity.....	76

Beeper Tone	76
Beeper Type	77
Beeper Length	77
PDF Decoding Recognition Intensity	77

DECODING PARAMETERS.....	78
Ink-Spread	79
Overflow Control	79
Interdigit Control.....	80
Decoding Safety.....	80
Puzzle Solver™	81

CODE SELECTION	82
EAN/UPC Family	84
2/5 Family	88
Code 39 Family.....	89
Code 128 Family.....	91
Code 93	92
Codabar Family.....	93
Codablock-A	95
Codablock-F.....	95
MSI	96
Plessey	97
Telepen.....	98
Delta IBM	99
Code 16K.....	100
Code 49	100
Pharmacode.....	101
PDF417	102

5 REFERENCES	103
5.1 RS232 Parameters	103
5.1.1 Handshaking	103
5.1.2 ACK/NACK from Host Protocol	104
5.1.3 FIFO.....	104
5.1.4 RX Timeout.....	104
5.2 Pen Parameters	105
5.2.1 Minimum Output Pulse.....	105
5.2.2 Overflow.....	105
5.2.3 Output and Idle Levels	106
5.2.4 Inter-Block Delay.....	106
5.3 Data Format	107
5.3.1 Header/Terminator Selection	107
5.3.2 Set Custom Extended Header/Terminator Keys	108
5.4 Power Save.....	110
5.4.1 Sleep State	110

5.4.2	Enter Sleep Timeout	110
5.4.3	Standby	110
5.5	Reading Parameters	110
5.5.1	Operating Modes	110
5.5.2	Reads per Cycle	112
5.6	Decoding Parameters	112
5.6.1	Ink-Spread	112
5.6.2	Overflow Control	113
5.6.3	Interdigit Control.....	113
5.7	Configuration Editing Commands	113
6	TECHNICAL FEATURES	114
	Reading Diagrams	115
A	CODE IDENTIFIER TABLE.....	117
B	HEX AND NUMERIC TABLE	121

1 INTRODUCTION

The TC1100 compact CCD reader is the perfect solution for many OEM applications. It contains a built-in decoder and multi-standard interface. Due to its well-balanced mix of technical characteristics it is perfect for integration into custom equipment, setting a new standard in this product class.

This Reference Manual provides connection diagrams, default parameter listing, complete application parameter settings, specific technical features and reading diagrams.

1.1 CONFIGURATION METHODS

1.1.1 Configuration for RS232 Interface Users

The easiest way to configure TC1100 is by using the **DL Sm@rtSet™** utility program installed from the CD included with this manual. It provides a user-friendly graphic interface that sends the command strings to the TC1100 and Help On-Line to explain configuration parameters.

This manual contains the complete set of command strings for TC1100 configuration. These strings must be sent via the RS232 interface using a terminal emulator such as HyperTerminal, or with the WinHost Terminal. Configurations can also be sent as batch files.

Refer to paragraph 3.2 for configuration procedures.

1.1.2 Configuration for Wedge Interface Users

For Wedge Interface Users, configuration can be accomplished either by reading the barcode labels available in this manual with the TC1100 (see chapter 4) or by reading the Return to RS232 Interface barcode and then configuring through the RS232 Interface.

To configure TC1100 by reading the configuration barcodes:

- 1) Open the folded page in Appendix B with the hex-numeric table and keep it open during the device configuration.
- 2) Read the **Enter Configuration** code ONCE, available at the top of each page of configuration.

- 3) Modify the desired parameters in one or more sections following the procedures given for each group.
- 4) Read the **Exit and Save Configuration** code ONCE, available at the top of each page of configuration.

Reference notes describing the operation of the more complex parameters are given in chapter 5.

1.2 STATUS INDICATORS

The reader has two LED indicators signaling several operating conditions which are described in the tables below.



TC1100 Scanner

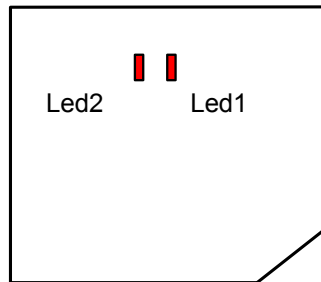

TC1100 Scan Engine

POWER UP

POWER ON / LED2	Meaning
ON	Power supply ON
OFF	Power supply OFF

DATA ENTRY

GOOD READ / LED1	Meaning
ON	Good read (LED1 will remain ON until status changes)
OFF	Miss read

1.3 AVAILABLE MODELS

The TC1100 reader is available in models that differ in regard to the following characteristics:

- Barcode type
- Enclosure

The following models are therefore available:

- TC1100-0100 = CCD Scan Engine for linear codes
- TC1100-0200 = CCD Scan Engine for linear and PDF417 codes
- TC1100-1100 = CCD Scanner for linear codes
- TC1100-1200 = CCD Scanner for linear and PDF417 codes

2 INSTALLATION

2.1 TC1100 CCD SCANNER

2.1.1 Mechanical Installation

The diagram below gives the overall dimensions of the reader and may be used for its installation.

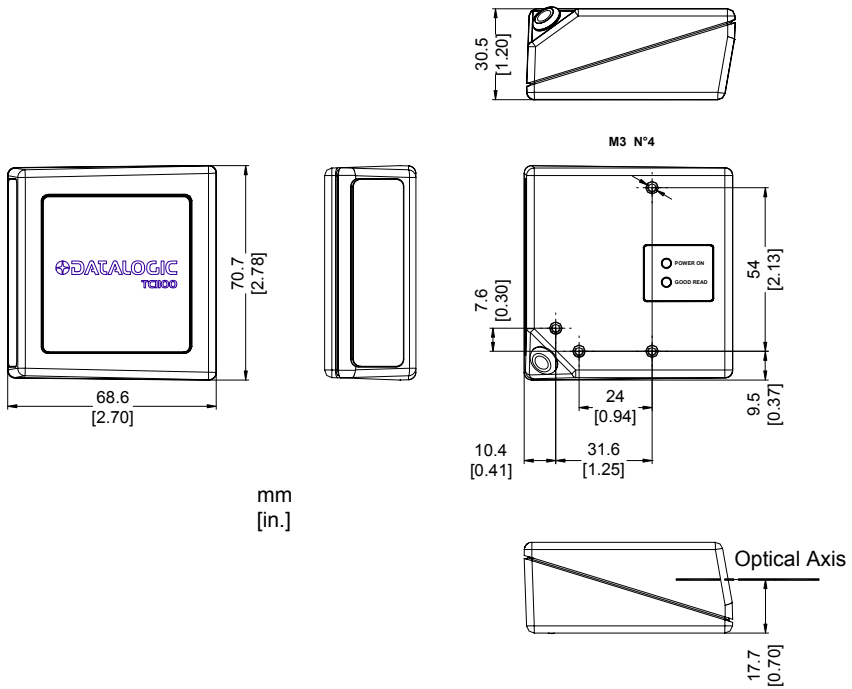

Figure 1 - Overall Dimensions

2.1.2 Electrical Connections

The TC1100 Scanner is equipped with a 25-pin female D-Sub connector for connection to the power supply and input/output signals. The details of the connector pins are indicated in the following table:

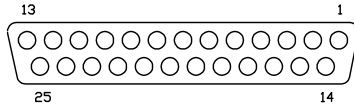

Figure 2 - 25-pin Female D-sub Connector

25-pin Connector		
1	Shield	earth ground
2	TX	transmit data
3	RX	receive data
4	RTS	request to send
5	CTS	clear to send
6	nc	not connected
7	SGND	signal ground
8	EXT BEEPER	external beeper connection
9	VCC+	+5 Vdc
10	nc	not connected
11	OUT+	see Figure 10
12	OUT-	
13	VCC+	+5 Vdc
14	nc	not connected
15	nc	not connected
16	nc	not connected
17	nc	not connected
18	EXT TRIG+	See Figures 6 to 9
19	EXT TRIG-	
20	DATAIN_WAND	
21	DATAOUT	
22	OUT-	
23	CLKIN	
24	CLKOUT	
25	GND	power ground

Table 1 - TC1100 Scanner Pinout

RS232 Interface

The TC1100 Scanner can communicate with the Host using the RS232 signals provided on the 25-pin connector. The pins are indicated in Table 1 and in the following diagram:

It is always advisable to use shielded cables. The overall maximum cable length must be less than 15 m (49.2 ft).

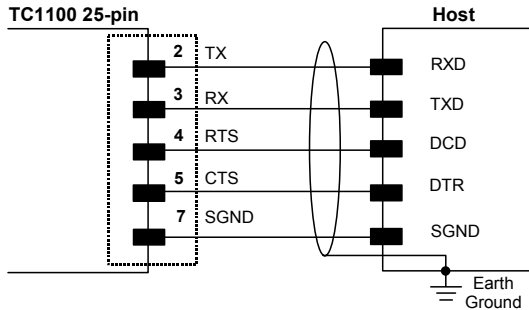

Figure 3 - RS232 Interface Connection to Host

WEDGE Interface

The TC1100 Scanner can communicate with the Host in a WEDGE Interface (Keyboard Emulation) using the signals provided on the 25-pin connector. The pins are indicated in Table 1 and in the following diagram:

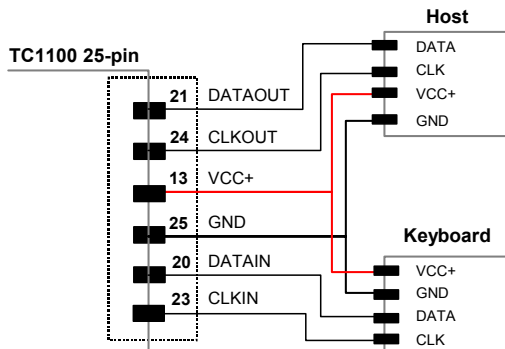

Figure 4 - Wedge Interface Connection to Host (PC AT) and Keyboard

PEN Emulation Interface

The TC1100 Scanner can communicate with the Host in a PEN Emulation Interface using the signals provided on the 25-pin connector. The pins are indicated in Table 1 and in the following diagram:

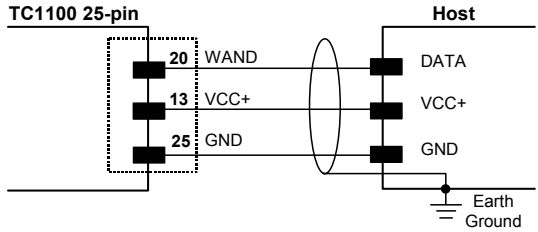

Figure 5 – Pen Emulation Interface Connection to Host

It is always advisable to use shielded cables.

Inputs

There is an input available on the TC1100 Scanner relative to the External Trigger. The pins are indicated in Table 1. These inputs are optocoupled and can be driven by both an NPN or PNP type command. The connections are indicated in the following diagrams:

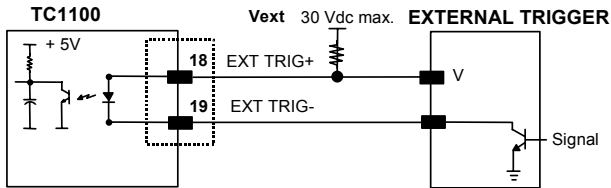

Figure 6 - Input NPN Command Using External Power

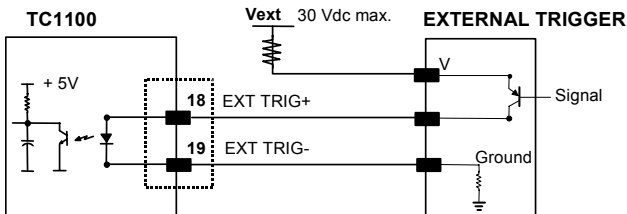

Figure 7 - Input PNP Command Using External Power

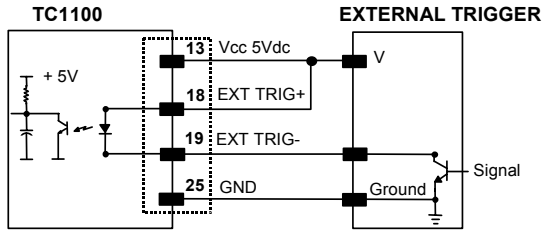

Figure 8 - Input NPN Command Using TC1100 Power

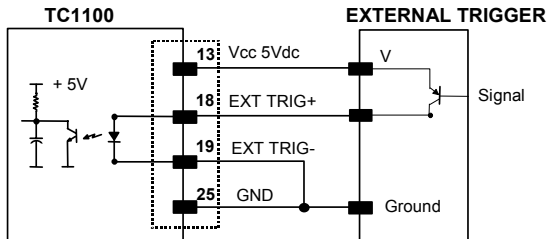

Figure 9 - Input PNP Command Using TC1100 Power

Outputs

There is an output available on the TC1100 Scanner relative to the Good Read event. The pins are indicated in Table 1. The connections are indicated in the following diagram:

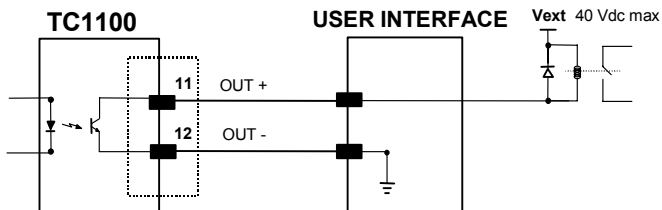

Figure 10 - Output Connection (Good Read). Example NPN

External Beeper Connection

A beeper output signal is provided on pin 8 so that an external piezoelectric buzzer with internal oscillator can be connected for Good Read acoustic signaling. The complete circuit to be built is shown in the schematic diagram below.

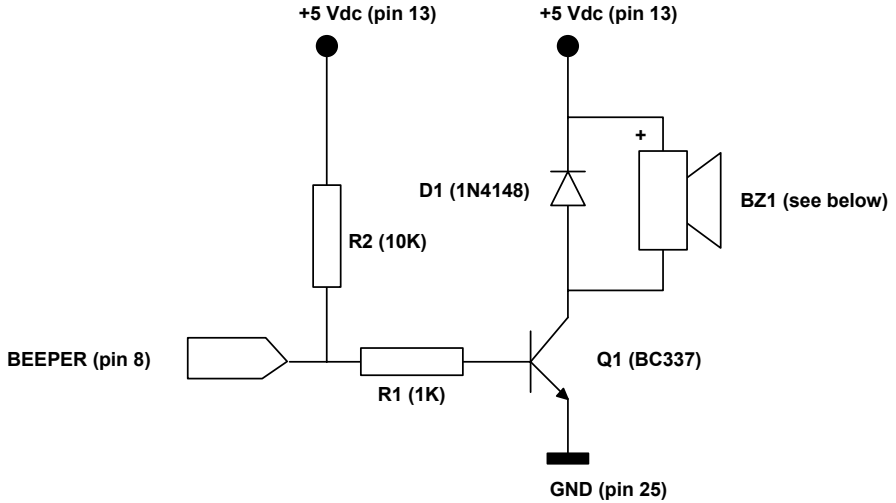

Figure 11 - TC1100 Scanner Beeper Connection

The following list indicates several piezoelectric buzzers that can be used in the circuitry above (part BZ1).

Manufacturer	Type
MURATA	PKB30SPC - 2001/3001
DIGISOUND	F/TCW05
CITIZEN	MEB-12C-5
BUJEON	BS12-A

See chapter 3 for Beeper Control commands.

2.2 TC1100 CCD SCAN ENGINE

2.2.1 Mechanical Installation

The diagram below gives the overall dimensions of the TC1100 Scan Engine and may be used for its installation.

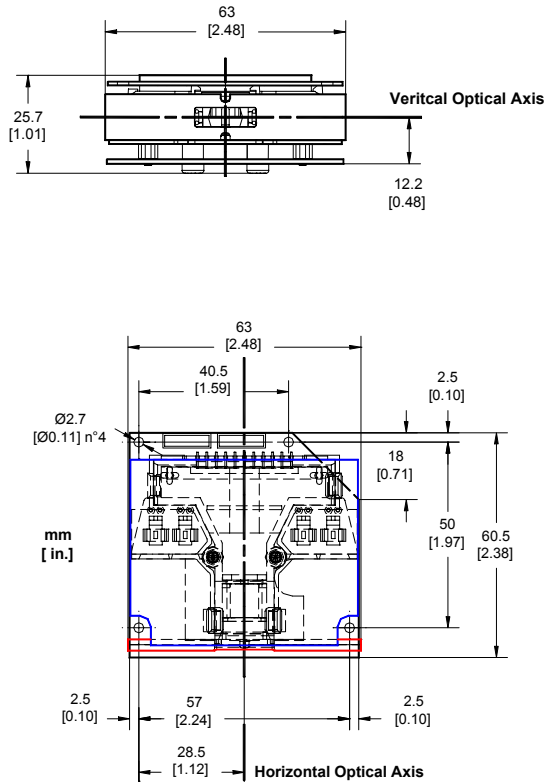

Figure 12 - Overall Dimensions

2.2.2 Electrical Connections

The TC1100 Scan Engine is equipped with two 8-pin DF13 connectors for connection to the power supply and input/output signals. The details of the connector pins are indicated in the following table:

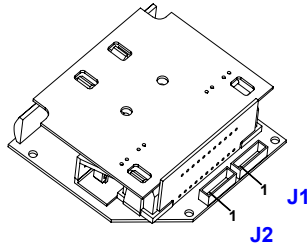

Figure 13 - 8-pin Connectors

J1		
1	SGND	signal ground
2	OUT-	see Figure 21
3	OUT+	
4	EXT BEEPER	beeper output signal
5	CTS	clear to send
6	RX	receive data
7	RTS	request to send
8	TX	transmit data
J2		
1	VCC+	+5 Vdc
2	GND	power ground
3	CLKOUT	
4	DATAOUT	
5	DATAIN_WAND	
6	CLKIN	
7	EXT TRIG+	See Figures 17 to 20
8	EXT TRIG-	

Table 2 - TC1100 Scan Engine Pinout

RS232 Interface

The TC1100 Scan Engine can communicate with the Host using the RS232 signals provided on the J1 connector. The pins are indicated in Table 1 and in the following diagram:

It is always advisable to use shielded cables. The overall maximum cable length must be less than 15 m (49.2 ft).

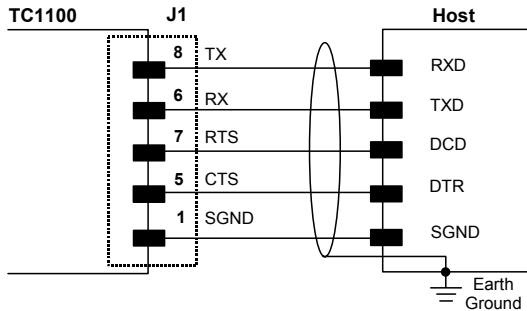

Figure 14 - RS232 Interface Connection to Host

WEDGE Interface

The TC1100 Scan Engine can communicate with the Host in a WEDGE Interface (Keyboard Emulation) using the signals provided on the J2 connector. The pins are indicated in Table 1 and in the following diagram:

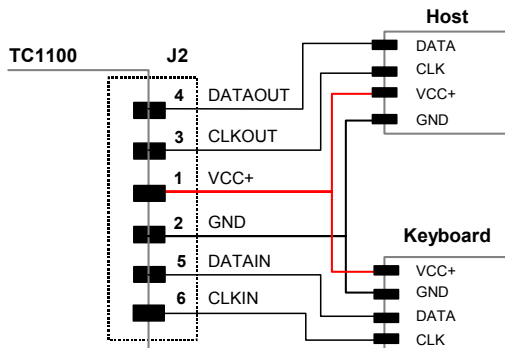

Figure 15 - Wedge Interface Connection to Host (PC AT) and Keyboard

PEN Emulation Interface

The TC1100 Scan Engine can communicate with the Host in a PEN Emulation Interface using the signals provided on the J2 connector. The pins are indicated in Table 1 and in the following diagram:

It is always advisable to use shielded cables.

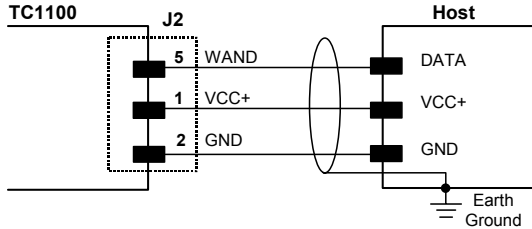

Figure 16 – Pen Emulation Interface Connection to Host

Inputs

There is an input available on the TC1100 Scan Engine relative to the External Trigger. The pins are indicated in Table 2. These inputs are optocoupled and can be driven by both an NPN or PNP type command. The connections are indicated in the following diagrams:

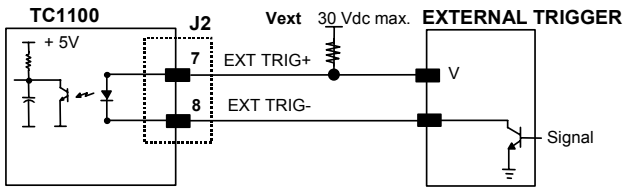

Figure 17 - Input NPN Command Using External Power

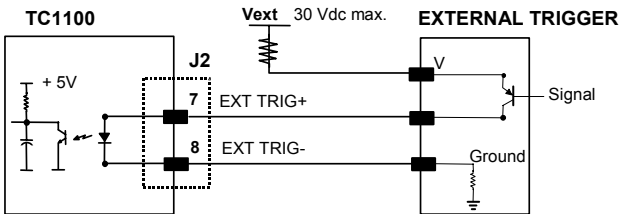

Figure 18 - Input PNP Command Using External Power

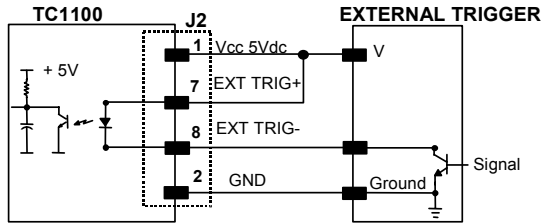

Figure 19 - Input NPN Command Using TC1100 Power

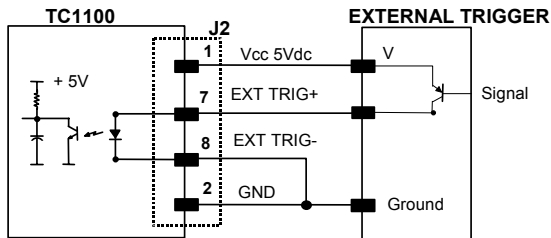

Figure 20 - Input PNP Command Using TC1100 Power

Outputs

There is an output available on the TC1100 Scan Engine relative to the Good Read event. The pins are indicated in Table 2. The connections are indicated in the following diagram:

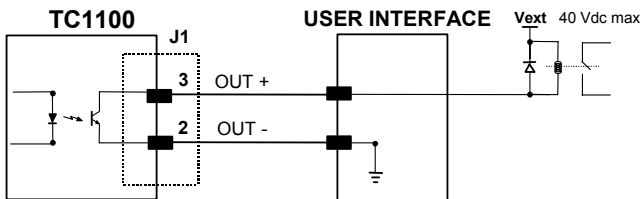

Figure 21 - Output Connection (Good Read). Example NPN

External Beeper Connection

A beeper output signal is provided on J1 pin 4 so that an external piezoelectric buzzer with internal oscillator can be connected for Good Read acoustic signaling. The complete circuit to be built is shown in the schematic diagram below.

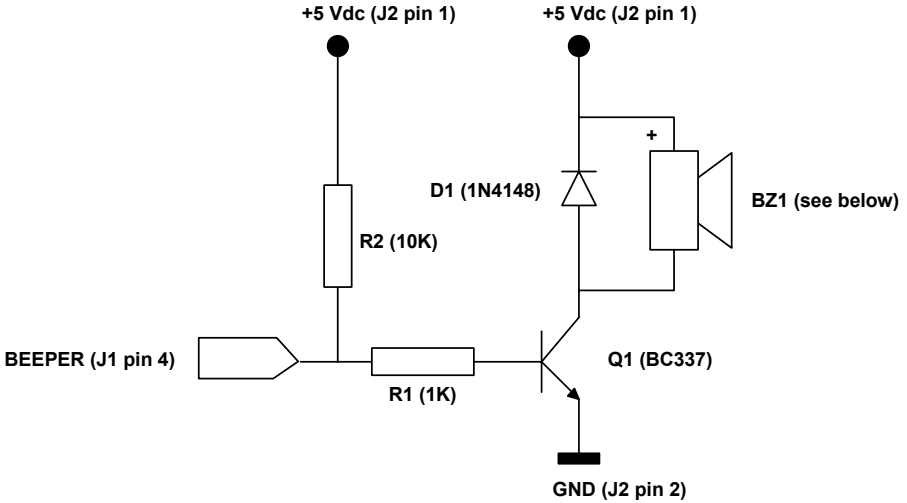

Figure 22 - TC1100 Scan Engine Beeper Connection

The following list indicates several piezoelectric buzzers that can be used in the circuitry above (part BZ1).

Manufacturer	Type
MURATA	PKB30SPC - 2001/3001
DIGISOUND	F/TCW05
CITIZEN	MEB-12C-5
BUJEON	BS12-A

See chapter 3 for Beeper Control commands.

2.3 POSITIONING

The TC1100 scanner is able to decode barcode labels at a variety of angles, however significant angular distortion may degrade reading performance.

When mounting the TC1100 take into consideration these three ideal label position angles: **Pitch 0°**, **Skew 10° to 30°** and **Tilt 0°**. Follow the suggestions for the best orientation:

The **Pitch** angle is represented by the value **P** in Figure 23. Position the reader in order to **minimize** the **Pitch** angle.

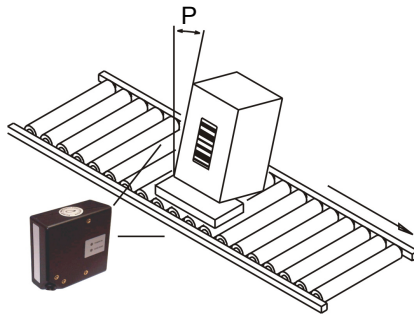

Figure 23 - Pitch Angle

The **Skew** angle is represented by the value **S** in Figure 24. Position the reader to **assure at least 10°** for the **Skew** angle. This avoids direct light reflection.

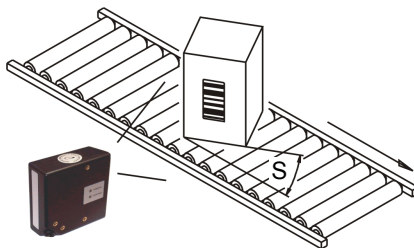

Figure 24 - Skew angle

The **Tilt** angle is represented by the value **T** in Figure 25. Position the reader in order to **minimize** the **Tilt** angle.

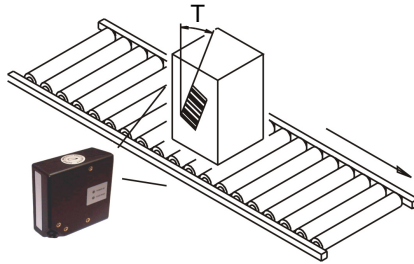

Figure 25 - Tilt angle

2.4 GFC-TC1100 ACCESSORY

The GFC-TC1100 is an 80° deflection mirror that is mounted directly to the TC1100 Scanner or Scan Engine.

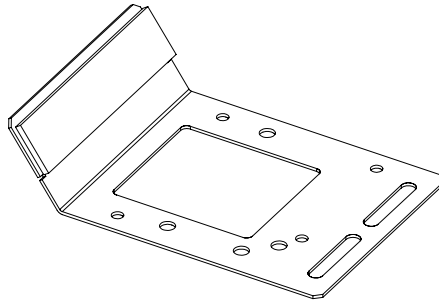

Figure 26 - GFC-TC1100

The overall dimensions are provided in the figure below and can be used for its mounting.

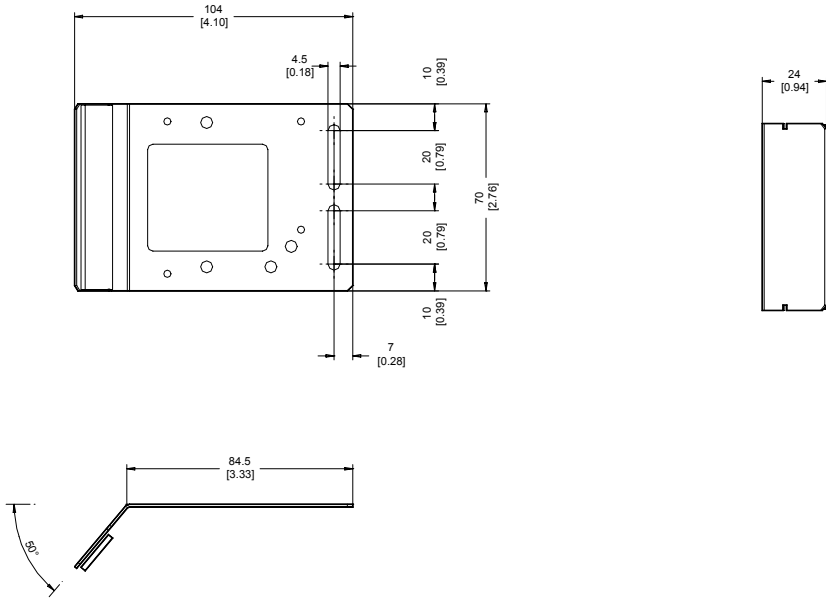

Figure 27 - GFC-TC1100 Overall Dimensions

To fix a TC1100-1xx Scanner to the GFC-TC1100, use the 4 **M 2.5x5** mm screws supplied with the GFC Kit. Refer to the figure below.

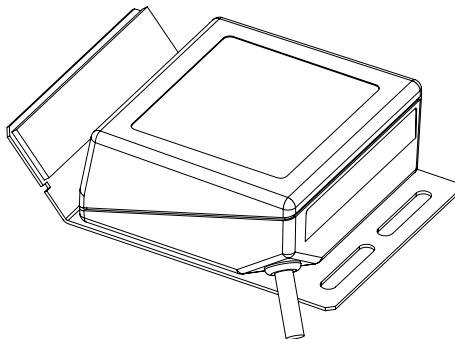

Figure 28 – Fixing TC1100 Scanner to GFC-TC1100

To fix a TC1100-0xxx Scan Engine to the GFC-TC1100, use the 4 **M 2.5x10** mm screws together with the 4 plastic spacers and nuts supplied with the GFC Kit. Refer to the figure below.

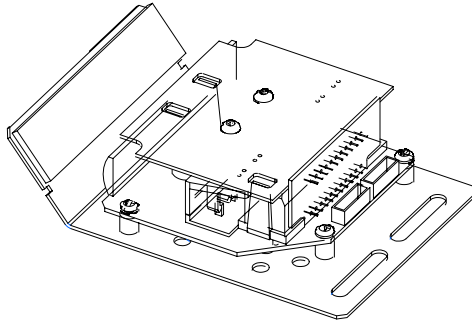

Figure 29 – Fixing TC1100 Scan Engine to GFC-TC1100

The 80° deflection mirror assures that the minimum skew angle is maintained to avoid direct light reflection which can degrade reading performance.

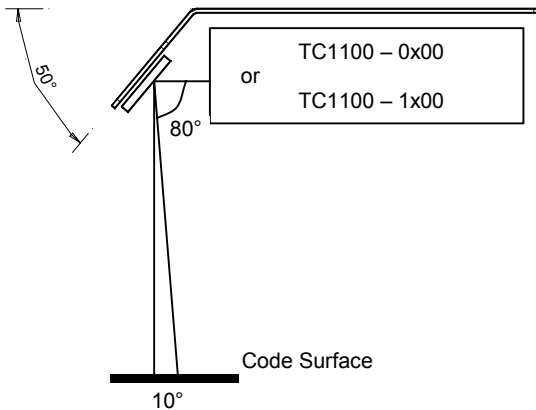

Figure 30 – Maintaining Minimum Skew Angle

3 SOFTWARE CONFIGURATION STRINGS

3.1 DEFAULT CONFIGURATION

RS232 INTERFACE

9600 baud, parity disabled, 8 data bits, 1 stop bit, handshaking disabled, ACK/NACK from Host disabled, 100 ms RX timeout, FIFO enabled, inter-character delay disabled

WEDGE INTERFACE

USA keyboard, caps lock off, delays disabled, control character emulation = ctrl+shift+key;

PEN Emulation INTERFACE

interpret mode, conversion to code 39 disabled, output level normal, idle level normal, minimum output pulse 600 μ s, overflow medium, inter-block delay disabled

DATA FORMAT

Code identifier disabled, field adjustment disabled, code length TX disabled, character replacement disabled, header = <STX>, terminator = <CR> <LF>, no read character = <CAN>

POWER SAVE

270 read/sec, sleep disabled, standby disabled

READING PARAMETERS

On-Line mode, beeper intensity = high intensity, beeper tone = tone 2, beeper type = monotone, beeper length = short

DECODING PARAMETERS

Ink spread enabled, overflow control enabled, interdigit control enabled, Puzzle Solver™ disabled, decoding safety = 1 read

CODE SELECTION**enabled codes**

- Interleaved 2 of 5
Check digit transmitted, variable length code; 4-99 characters
- EAN8/EAN13UPC A/UPC B without ADD ON
Check digit transmitted, no conversions
- Code 39
variable length code; 1-99 characters
- Code 128
Check digit not transmitted, variable length code; 1-99 characters
- PDF417 (TC1100-x200 **only**)

disabled codes

*EAN 128, ISBT128, Code 93, Codabar, pharmaceutical codes, Delta IBM, Code 16K, Code 49, (MSI/Plessey, Telepen, Pharmacode **only** TC1100-x100), (Codablock-A, Codablock-F Standard and EAN **only** TC1100-x200)*

3.2 TC1100 CONFIGURATION

TC1100 is factory set for RS232 Interface applications. The easiest way to configure TC1100 is by using the **DL Sm@rtSet™** utility program installed from the CD included with this manual. Otherwise you can configure the scanner using the serial string which follow:

To configure TC1100 by using the configuration strings:

- 1) Connect your TC1100 to a PC RS232 port according to the information in chapter 2. Set the PC serial port to the TC1100 default RS232 communication parameters.
- 2) Using a Terminal Emulation Program, send the Restore Default string to the reader using the syntax described on the next page.
- 3) Send all the necessary command strings according to your application's requirements.



CAUTION

The WEDGE or PEN Emulation interface selections must be sent last since they will cause the reader to no longer accept RS232 communications.

If working with the Wedge or Pen emulation interfaces, it is possible to return to the RS232 connection by reading the code given below:

Return to RS232 Interface



For WEDGE or PEN Emulation Users

Command Syntax

The command syntax is given below with an example:

\$+	Command(s)	\$-	<CR>
-----	------------	-----	------

The new setting will be definitive (stored in FLASH EPROM)

Example:

Multiple command programming sequence:

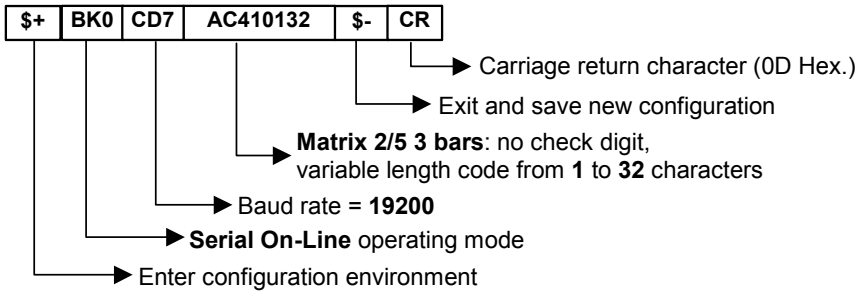

Each configuration parameter setting removes the condition previously active for that parameter.



NOTE

The device buffer can contain about 400 characters. If your programming string goes over this value, you must split it into separate groups and send each group after a delay of at least 3 seconds to give the reader time to empty the buffer and interpret the commands.

SERIAL CONFIGURATION STRINGS

ENTER/EXIT CONFIGURATION COMMANDS	
DESCRIPTION	STRING
Enter Configuration	\$+
Exit and Save Configuration	\$-
Restore Default	\$\$* <CR>
Transmit Software Release (not for PEN emulation)	\$\$! <CR>
Get Configuration from Reader (not for PEN emulation)	\$\$& <CR>

These commands do not require \$-.

INTERFACE SELECTION			
DESCRIPTION	STRING		
RS232	CP0		
WEDGE	for IBM AT	CP500	
	for IBM Terminals: 31xx, 32xx, 34xx, 37xx; make-break keyboard	CP501	
	for IBM Terminals: 31xx, 32xx, 34xx, 37xx; make-only keyboard	CP502	
	Keyboard Type for IBM Terminals 31xx, 32xx, 34xx, 37xx	typewriter	FK0
		advanced	FK1
	for IBM XT	CP503	
	for IBM Terminal 3153	CP504	
	for IBM PC Notebook	CP505	
	for IBM SURE1	CP506	
	for IBM AT - ALT mode	CP507	
	for IBM PC Notebook - ALT mode	CP508	
	for Wyse Terminal - ANSI Keyboard	CP509	
	for Wyse Terminal - PC Keyboard	CP510	
	for Wyse Terminal - ASCII Keyboard	CP511	
	for Wyse Terminal - VT220 style Keyboard	CP514	
for Digital Terminals VT2xx/3xx/4xx	CP512		
for Apple ADB Bus	CP513		
PEN EMULATION	CP6		

RS232		
DESCRIPTION		STRING
Baud rate	150	CD0
	300	CD1
	600	CD2
	1200	CD3
	2400	CD4
	4800	CD5
	9600	CD6
	19200	CD7
	38400	CD8
Parity	none	CC0
	even	CC1
	odd	CC2
Data bits	7	CA0
	8	CA1
	9	CA2
Stop bits	1	CB0
	2	CB1
Handshaking	disable	CE0
	RTS/CTS	CE1
	XON/XOFF	CE2
	RTS always On	CE3
ACK/NACK Protocol	disable	CF0
	enable	CF3
FIFO	disable	EC0
	enable	EC1
Inter-character delay (<i>ms</i>)		CK00 - CK99
RX Timeout (<i>100 ms</i>)		CL00 - CL99

WEDGE		
DESCRIPTION		STRING
Keyboard nationality	Belgian	FJ7
	English	FJ4
	French	FJ2
	German	FJ3
	Italian	FJ1
	Spanish	FJ6
	Swedish	FJ5
	USA	FJ0

WEDGE (continued)		
DESCRIPTION		STRING
Caps Lock	caps Lock ON	FE1
	caps Lock OFF	FE0
Num Lock	Toggle Num Lock	FL1
	Num Lock Unchanged	FL0
Delays	Inter-Character (<i>ms</i>)	CK00 - CK99
	Inter-Code (<i>s</i>)	FG00 - FG99
Control Character Emulation	Ctrl + Shift + Key	FO0
	Ctrl + Key	FO1

PEN		
DESCRIPTION		STRING
Operating mode	interpret (does not require \$+ or \$-)	\$]
	transparent (does not require \$+ or \$-)	[\$
Minimum output pulse	200 μ s	DG0
	400 μ s	DG1
	600 μ s	DG2
	800 μ s	DG3
	1 ms	DG4
	1.2 ms	DG5
Conversion to Code 39	disable conversion to Code 39	DA0
	enable conversion to Code 39	DA1
Output level	normal	DD0
	inverted	DD1
Idle level	normal	DE0
	inverted	DE1
Overflow	narrow overflow	DH0
	medium overflow	DH1
	wide overflow	DH2
Inter-Block delay (<i>100 ms</i>)		CK00-CK99

DATA FORMAT		
NOT FOR PEN EMULATION INTERFACES		
DESCRIPTION		STRING
Code Identifier	disable	EB0
	Datologic standard	EB1
	AIM standard	EB2
	Custom	EB3
Custom Code Identifier		EHabc
Headers	no header	EA00
	one character	EA01x
	two characters	EA02xx
	three characters	EA03xxx
	four characters	EA04xxxx
	five characters	EA05xxxxx
	six characters	EA06xxxxxx
	seven characters	EA07xxxxxxxx
eight characters	EA08xxxxxxxxx	
Terminators	no terminator	EA10
	one character	EA11x
	two characters	EA12xx
	three characters	EA13xxx
	four characters	EA14xxxx
	five characters	EA15xxxxx
	six characters	EA16xxxxxx
	seven characters	EA17xxxxxxxx
eight characters	EA18xxxxxxxxx	
No Read Character	disable	EP0
	enable	EP1x

a = ASCII character.

b, c, x = HEX values representing an ASCII character.

a = ASCII character of the DATALOGIC STANDARD Code Identifier from the table on page 60.

b = Hex value of the first Custom Code Identifier character from **00** to **FE**;
FF = disable Code Identifier

c = Hex value of the second Custom Code Identifier character from **00** to **FE**;
FF = disable second character of Custom Code Identifier

x = Hex value from **00** to **FE**

DATA FORMAT (continued)		
NOT FOR PEN EMULATION INTERFACES		
DESCRIPTION		STRING
Code Length Tx	not transmitted	EE0
	transmitted in variable-digit format	EE1
	transmitted in fixed 4-digit format	EE2
Field Adjustment	disable	EF0
	right addition	EFa0d
	left addition	EFa1d
	right deletion	EFa2d
	left deletion	EFa3d
Field Adjustment Character		EGe
Character Replacement	disable character replacement	EO0
	first character replacement	EO1afg
	second character replacement	EO2afg
	third character replacement	EO3afg

a = ASCII character.

d = a number from the Hex/Numeric Table

e, f, g = HEX values representing an ASCII character

a = ASCII character of the DATALOGIC STANDARD Code Identifier from the table on page 60.

d = a number in the range **01-32** from the Hex/Numeric Table

e = Hex value from **00** to **FE**

f = Hex value of the character to be replaced from **00** to **FE**

g = Hex value of the new character to insert from **00** to **FE**

FF = replace with no new character (remove character)

POWER SAVE		
DESCRIPTION		STRING
Read Rate	67 reads per sec.	BT0
	135 reads per sec.	BT1
	270 reads per sec.	BT2
Sleep State	disable	BQ0
	enable	BQ1
Enter Sleep Timeout (100 ms)		BR00-BR99
Standby	enable	BM0
	disable	BM1

READING PARAMETERS			
DESCRIPTION		STRING	
Operating Modes See par. 5.5.1 for details	serial on-line		BK0
	on-line		BK1
	automatic		BK3
	automatic/lighting system standby		BK2
	Test Mode	disable enable	#+DStat0<CR> #+DStat1<CR>
Beeper Intensity	very low intensity		BG0
	low intensity		BG1
	medium intensity		BG2
	high intensity		BG3
Beeper Tone	Tone 1		BH0
	Tone 2		BH1
	Tone 3		BH2
	Tone 4		BH3
Beeper Type	monotone		BJ0
	bitonal		BJ1
Beeper Length	long		BI0
	short		BI1
PDF Decoding Recognition Intensity	low		BW0
	high		BW1

DECODING PARAMETERS			
DESCRIPTION		STRING	
Ink-Spread	disable		AX0
	enable		AX1
Overflow Control	disable		AW1
	enable		AW0
Interdigit Control	disable		AV0
	enable		AV1
Puzzle Solver™	disable		AU0
	enable		AU1
Decoding Safety	one read		ED0
	two reads		ED1
	three reads		ED2
	four reads		ED3

CODE SELECTION			
DESCRIPTION		STRING	
DISABLE ALL FAMILY CODES		AZ0	
EAN/UPC	Disable EAN/UPC family		AA0
	EAN 8/EAN 13/UPC A/UPC E	without ADD ON	AA1
		with ADD ON	AA5
		with and without ADD ON	AA8

CODE SELECTION (continued)			STRING
DESCRIPTION			
	EAN 8/EAN 13	without ADD ON	AA3
		with ADD ON 2 ONLY	AAK
		with ADD ON 5 ONLY	AAL
		with ADD ON 2 AND 5	AA6
	UPC A/UPC E	without ADD ON	AA4
		with ADD ON 2 ONLY	AAM
		with ADD ON 5 ONLY	AAN
		with ADD ON 2 AND 5	AA7
	EAN 8 check digit transmission	disable	AAG0
		enable	AAG1
	EAN 13 check digit transmission	disable	AAH0
		enable	AAH1
	UPC A check digit transmission	disable	AAI0
		enable	AAI1
UPC E check digit transmission	disable	AAJ0	
	enable	AAJ1	
	Conversions	UPC E to UPC A	AAA
		UPC E to EAN 13	AAB
		UPC A to EAN 13	AAC
		EAN 8 to EAN 13	AAD
	ISBN Conversion codes	enable ISBN	AP1
		enable ISSN	AP2
		enable ISBN and ISSN	AP3
		disable ISBN and ISSN	AP0
Code 39	disable Code 39 family		AB0
	Standard	no check digit control	AB11
		check digit control and transmission	AB12
		check digit control without transmission	AB13
	Full ASCII	no check digit control	AB21
		check digit control and transmission	AB22
		check digit control without transmission	AB23
CIP 39		AB3	
Code 32		AB4	
code length		AB*xxxx	

xxxx = ASCII numbers that define the code length where:

- First 2 digits = minimum acceptable code length.
- Second 2 digits = maximum acceptable code length.

The minimum code length must always be less than or equal to the maximum.

The maximum code length for all codes is 99 characters.

Examples:

0132 = variable length from 1 to 32 digits in the code.

1010 = 10 digit code length only.

CODE SELECTION (continued)			
DESCRIPTION		STRING	
2/5	disable Code 2/5 family		AC0
	Interleaved 2/5	no check digit control	AC11xxxx
		check digit control and transmission	AC12xxxx
		check digit control without transmission	AC13xxxx
	Normal 2/5 5 bars	no check digit control	AC21xxxx
		check digit control and transmission	AC22xxxx
		check digit control without transmission	AC23xxxx
	Industrial 2/5 (IATA)	no check digit control	AC31xxxx
		check digit control and transmission	AC32xxxx
		check digit control without transmission	AC33xxxx
	Matrix 2/5 3 bars	no check digit control	AC41xxxx
check digit control and transmission		AC42xxxx	
check digit control without transmission		AC43xxxx	
CIP/HR		AC5	
Codabar	disable Codabar family		AD0
	Standard	no start/stop character equality control nor transmission	AD111
		no start/stop character equality control but transmission	AD112
		start/stop character equality control but no transmission	AD121
		start/stop character equality control and transmission	AD122
	ABC Codabar	no start/stop character equality control but transmission	AD212
	Codabar ABC forced concatenation		AD232
	code length		AD*xxxx
	start/stop character case in transmission	lower case	ADA0
		upper case	ADA1

xxxx = ASCII numbers that define the code length where:

- First 2 digits = minimum acceptable code length.
- Second 2 digits = maximum acceptable code length.

The minimum code length must always be less than or equal to the maximum.

The maximum code length for all codes is 99 characters:

EXAMPLES:

0132 = variable length from 1 to 32 digits in the code.

1010 = 10 digit code length only.

CODE SELECTION (continued)		
DESCRIPTION		STRING
Code 128	disable Code 128 family	AI0
	enable Code 128	AI11
	control without transmission of check digit	
	enable EAN 128	AI21
	control without transmission of check digit	
	code length	AI Lxxyy
	tx GS before Code	disable enable
ISBT 128	enable ISBT 128	AI31
Code 93	disable Code 93 family	AK0
	enable Code 93	AK1
	control without transmission of check digit	
Codablock-A (TC1100-x200 only)	disable	A00
	enable	A01
Codablock-F (TC1100-x200 only)	disable the family	AN0
	enable Standard	AN1
	enable EAN	AN2
MSI (TC1100-x100 only)	disable the family	AE0
	no check	AE1
	MOD10 no tx	AE2
	MOD10 with tx	AE3
	MOD11-MOD10 no tx	AE4
	MOD11-MOD10 with tx	AE5
	MOD10-MOD10 no tx	AE6
	MOD10-MOD10 with tx	AE7
Plessey (TC1100-x100 only)	disable the family	AF0
	Standard no check	AF11
	Standard check - with tx	AF12
	Standard check - no tx	AF13
	Anker no check	AF21
	Anker check - with tx	AF22
	Anker check - no tx	AF23
Telepen (TC1100-x100 only)	disable the family	AL0
	Numeric no check	AL11
	Numeric check - with tx	AL12
	Numeric check - no tx	AL13
	Alpha no check	AL21
	Alpha check - with tx	AL22
	Alpha check - no tx	AL23

xx = ASCII numbers that define the minimum acceptable code length;

yy = ASCII numbers that define the maximum acceptable code length;

CODE SELECTION (continued)		
DESCRIPTION		STRING
Delta IBM	disable the family	AH0
	no check	AH1
	Type 1 check	AH2
	Type 2 check	AH3
Code 16K	disable	AJ0
	enable	AJ1
Code 49	disable	AM0
	enable	AM1
PDF417 (TC1100- x200 only)	disable	AR0
	enable	AR1
Pharmacode (TC1100- x100 only)	disable	AQ0
	forward code TX direction	AQ1xxyy
	reverse code TX direction	AQ2xxyy
	overflow ratio	AQazz

xx = ASCII numbers that define the minimum acceptable code length;

yy = ASCII numbers that define the maximum acceptable code length;

The minimum code length is 2 characters.

The maximum code length is 16 characters.

zz = ASCII numbers that define the overflow ratio value in the range 02-10.

4 BARCODE CONFIGURATION



CAUTION

The Barcode Configuration is suggested only when using the WEDGE or PEN Emulation interface.

4.1 INITIAL SETUP

The following procedure allows preparing your TC1100 to read barcodes by using the default settings.

RESTORE DEFAULT

1. Read the restore default parameters code below.

Restore TC1100 Default



INTERFACE SELECTION

2. Read the interface selection code for your application.

RS232



PEN



WEDGE

IBM AT or PS/2 PCs



IBM XT



PC Notebook



IBM SURE1



IBM Terminal 3153



WEDGE (continued)**IBM Terminals 31xx, 32xx, 34xx, 37xx:**

To select the interface for these IBM Terminals, read the correct KEY TRANSMISSION code. Select the KEYBOARD TYPE if necessary (default = advanced keyboard).

KEY TRANSMISSION MODE

make-only keyboard



make-break keyboard



KEYBOARD TYPE

◆ advanced keyboard



typewriter keyboard



WEDGE (continued)

ALT MODE

The ALT-mode selection allows barcodes sent to the PC to be interpreted correctly independently from the Keyboard Nationality used. **You do not need to make a Keyboard Nationality selection.**

(default = Num Lock Unchanged). **Make sure the Num Lock key on your keyboard is ON.**

IBM AT - ALT mode



PC Notebook - ALT mode



WYSE TERMINALS

ANSI Keyboard



PC Keyboard



ASCII Keyboard



VT220 style Keyboard



WEDGE (continued)**DIGITAL TERMINALS**

VT2xx/VT3xx/VT4xx

**APPLE**

APPLE ADB Bus

**YOUR READER IS NOW READY TO READ BARCODES.**

To change the default settings see par. 4.2.

4.2 CHANGING DEFAULT SETTINGS

Once your reader is setup, you can change the default parameters to meet your application needs. Refer to the preceding paragraph for initial configuration in order to set the default values and select the interface for your application.

In this manual, the configuration parameters are divided into logical groups making it easy to find the desired function based on its reference group.

The first three groups are for Standard Interface parameter configuration:

- **RS232**
- **WEDGE**
- **PEN EMULATION**

The following parameter groups are common to all interface applications:

DATA FORMAT parameters regard the messages sent to the Host system for all interfaces except Pen Emulation.

POWER SAVE manages overall current consumption in the reading device.

READING PARAMETERS control various operating modes and indicator status functioning.

DECODING PARAMETERS maintain correct barcode decoding in certain special reading conditions.

CODE SELECTION parameters allow configuration of a personalized mix of codes, code families and their options.

RS232 PARAMETERS

⊙	BAUD RATE	⊙
⊙	PARITY	⊙
⊙	DATA BITS	⊙
⊙	STOP BITS	⊙
⊙	HANDSHAKING	⊙
⊙	ACK/NACK PROTOCOL	⊙
⊙	FIFO	⊙
⊙	INTER-CHARACTER DELAY	⊙
⊙	RX TIMEOUT	⊙

1. Read the **Enter Configuration** code ONCE, available at the top of each page.
2. Read configuration codes from the desired groups.
 -  = Read the code and follow the procedure given
 - ◆ = Default value
3. Read the **Exit and Save Configuration** code ONCE, available at the top of each page.



RS232

BAUD RATE

150 baud



300 baud



600 baud



1200 baud



2400 baud



4800 baud



◆ 9600 baud



19200 baud



38400 baud





RS232



PARITY

◆ none



even parity



odd parity



DATA BITS

7 bits



◆ 8 bits



9 bits





STOP BITS

◆ 1 stop bit



2 stop bits



HANDSHAKING

◆ disable



hardware (RTS/CTS)



software (XON/XOFF)



RTS always ON



See par. 5.1.1 for details.



ACK/NACK PROTOCOL

◆ disable



enable



See par. 5.1.2 for details.

FIFO

disable



◆ enable



See par. 5.1.3 for details.



INTER-CHARACTER DELAY

delay between characters transmitted to Host



Read 2 numbers from the table where:

- 00 = DELAY disabled
- 01-99 = DELAY from 1 to 99 milliseconds

◆ delay disabled

RX TIMEOUT

timeout control in reception from Host



Read 2 numbers from the table where:

- 00 = TIMEOUT disabled
- 01-99 = TIMEOUT from .1 to 9.9 seconds

◆ rx timeout 100 ms

See par. 5.1.4 for details.

WEDGE PARAMETERS

⊙	<i>KEYBOARD NATIONALITY</i>	⊙
⊙	<i>CAPS LOCK</i>	⊙
⊙	<i>NUM LOCK</i>	⊙
⊙	<i>INTER-CHARACTER DELAY</i>	⊙
⊙	<i>INTER-CODE DELAY</i>	⊙
⊙	<i>KEYBOARD SETTING</i>	⊙
⊙	<i>CONTROL CHARACTER EMULATION</i>	⊙

1. Read the **Enter Configuration** code ONCE, available at the top of each page.
2. Read configuration codes from the desired groups.
 -  = Read the code and follow the procedure given
 - ◆ = Default value
3. Read the **Exit and Save Configuration** code ONCE, available at the top of each page.



KEYBOARD NATIONALITY

Belgian



English



French



German



Italian



Spanish



Swedish



◆ USA





WEDGE

CAPS LOCK

◆ caps lock OFF



caps lock ON



Select the appropriate code to match your keyboard caps lock status.

Note: For **IBM AT and PC Notebook** interface selections, the caps lock status is automatically recognized, therefore this command is not necessary.

NUM LOCK

toggle num lock



◆ num lock unchanged



This selection is used together with the Alt Mode interface selection for AT or Notebook PCs.

It changes the way the Alt Mode procedure is executed, therefore it should be set as follows:

- if your keyboard Num Lock is normally on use **num lock unchanged**
- if your keyboard Num Lock is normally off use **toggle num lock**

In this way the device will execute the Alt Mode procedure correctly for your application.



INTER-CHARACTER DELAY

delay between characters transmitted to Host

**Read 2 numbers from the table where:**

00 = DELAY disabled
 01-99 = DELAY from **1** to **99** milliseconds

◆ delay disabled

INTER-CODE DELAY

delay between codes transmitted to Host

**Read 2 numbers from the table where:**

00 = DELAY disabled
 01-99 = DELAY from **1** to **99** seconds

◆ delay disabled



KEYBOARD SETTING

ALPHANUMERIC KEYBOARD SETTING

The reader can be used with terminals or PCs with various keyboard types and nationalities through a simple keyboard setting procedure.

The type of computer or terminal must be selected before activating the keyboard setting command.

Keyboard setting consists of communicating to the reader how to send data corresponding to the keyboard used in the application. The keys must be set in a specific order.

Press and release a key to set it.

Some characters may require more than one key pressed simultaneously during normal use (refer to the manual of your PC or terminal for keyboard use). The exact sequence must be indicated to the reader in this case pressing and releasing the different keys.

Example:

If one has to press the "Shift" and "4" keys simultaneously on the keyboard to transmit the character "\$" to the video, to set the "\$", press and release "Shift" then press and release "4".

Each pressed and released key must generate an acoustic signal on the reader, otherwise repress the key. Never press more than one key at the same time, even if this corresponds to the normal use of your keyboard.

Press "Backspace" to correct a wrong key entry. In this case the reader emits 2 beeps.

Note: "CAPS LOCK" and "NUM LOCK" must be off before starting the keyboard setting procedure. "SHIFT" must be repressed for each character and cannot be substituted by "CAPS LOCK".

setting the alphanumeric keyboard



Read the code above.

Press the keys shown in the following table according to their numerical order.

Some ASCII characters may be missing as this depends on the type of keyboard: these are generally particular characters relative to the various national symbolologies. In this case:

- **The first 4 characters (Shift, Alt, Ctrl, and Backspace) can only be substituted with keys not used, or substituted with each other.**
- characters can be substituted with other single symbols (e.g. "SPACE") even if not included in the barcode set used.
- characters can be substituted with others corresponding to your keyboard.

The reader signals the end of the procedure with 2 beeps indicating the keys have been registered.

WEDGE

01 : Shift		
02 : Alt		
03 : Ctrl		
04 : Backspace		
05 : SPACE	28 : 7	51 : N
06 : !	29 : 8	52 : O
07 : "	30 : 9	53 : P
08 : #	31 : :	54 : Q
09 : \$	32 : ;	55 : R
10 : %	33 : <	56 : S
11 : &	34 : =	57 : T
12 : '	35 : >	58 : U
13 : (36 : ?	59 : V
14 :)	37 : @	60 : W
15 : *	38 : A	61 : X
16 : +	39 : B	62 : Y
17 : ,	40 : C	63 : Z
18 : -	41 : D	64 : [
19 : .	42 : E	65 : \
20 : /	43 : F	66 :]
21 : 0	44 : G	67 : ^
22 : 1	45 : H	68 : _ (underscore)
23 : 2	46 : I	69 : `
24 : 3	47 : J	70 : {
25 : 4	48 : K	71 :
26 : 5	49 : L	72 : }
27 : 6	50 : M	73 : ~
		74 : DEL



CONTROL CHARACTER EMULATION

◆ Ctrl + Shift + Key



Ctrl + Key



PEN EMULATION

⊙	OPERATING MODE	⊙
⊙	MINIMUM OUTPUT PULSE	⊙
⊙	CONVERSION TO CODE 39	⊙
⊙	OVERFLOW	⊙
⊙	OUTPUT LEVEL	⊙
⊙	IDLE LEVEL	⊙
⊙	INTER-BLOCK DELAY	⊙

1. Read the **Enter Configuration** code ONCE, available at the top of each page.
2. Read configuration codes from the desired groups.
 -  = Read the code and follow the procedure given
 - ◆ = Default value
3. Read the **Exit and Save Configuration** code ONCE, available at the top of each page.

PEN EMULATION

The operating mode parameters are complete commands and do not require reading the Enter and Exit configuration codes.

OPERATING MODE

◆ interpret mode



Interprets commands without sending them to the decoder.

transparent mode



Sends commands to the decoder without interpreting them.



MINIMUM OUTPUT PULSE



See par. 5.2.1 for details.



PEN EMULATION



CONVERSION TO CODE 39

◆ disable conversion to Code 39



Transmits codes in their original format.

enable conversion to Code 39



Converts codes read into Code 39 format.



OVERFLOW

narrow



◆ medium



wide



See par. 5.2.2 for details.

OUTPUT LEVEL

◆ normal

(white = logic level 0)



inverted

(white = logic level 1)



See par. 5.2.3 for details.



PEN EMULATION

IDLE LEVEL

◆ normal
(black level)



inverted
(white level)



See par. 5.2.3 for details.

INTER-BLOCK DELAY

delay between character blocks transmitted to Host



Read 2 numbers from the table where:

00 = DELAY disabled

01-99 = DELAY from .1 to **9.9** seconds

◆ delay disabled

See par. 5.2.4 for details

DATA FORMAT

NOT FOR PEN INTERFACES

⊙	CODE IDENTIFIER	⊙
⊙	CUSTOM CODE IDENTIFIER	⊙
⊙	HEADER	⊙
⊙	TERMINATOR	⊙
⊙	FIELD ADJUSTMENT	⊙
⊙	FIELD ADJ. CHARACTER	⊙
⊙	CODE LENGTH TX	⊙
⊙	CHARACTER REPLACEMENT	⊙
⊙	NO READ CHARACTER	⊙

1. Read the **Enter Configuration** code ONCE, available at the top of each page.
2. Read configuration codes from the desired groups.
 -  = Read the code and follow the procedure given
 - ◆ = Default value
3. Read the **Exit and Save Configuration** code ONCE, available at the top of each page.

DATA FORMAT

CODE IDENTIFIER TABLE			
CODE	AIM STANDARD	DATALOGIC STANDARD	Custom
2/5 interleaved] I y	N	
2/5 industrial] X y	P	
2/5 normal 5 bars] S y	O	
2/5 matrix 3 bars] X y	Q	
EAN 8] E 4	A	
EAN 13] E 0	B	
UPC A] X y	C	
UPC E] X y	D	
EAN 8 with 2 ADD ON] E 5	J	
EAN 8 with 5 ADD ON] E 6	K	
EAN 13 with 2 ADD ON] E 1	L	
EAN 13 with 5 ADD ON] E 2	M	
UPC A with 2 ADD ON] X y	F	
UPC A with 5 ADD ON] X y	G	
UPC E with 2 ADD ON] X y	H	
UPC E with 5 ADD ON] X y	I	
Code 39] A y	V	
Code 39 Full ASCII] A y	W	
CODABAR] F y	R	
ABC CODABAR] X y	S	
Code 128] C y	T	
EAN 128] C y	k	
ISBT 128] C4	f	
Code 93] G y	U	
CIP/39] X y	Y	
CIP/HR] X y	e	
Code 32] X y	X	
Codablock-A] O 6	n	
Codablock-F Std] O 4	l	
Codablock-F EAN] O 5	m	
MSI] M y	Z	
Plessey Standard] P 0	a	
Plessey Anker] P 1	o	
Telepen] X 0	d	
Delta IBM] X 0	c	
Code 16K] K 0	p	
Code 49] T y	q	
PDF417] L 0	r	
Pharmacode		s	

DATA FORMAT

- AIM standard identifiers are not defined for all codes: the X identifier is assigned to the code for which the standard is not defined. The y value depends on the selected options (check digit tested or not, check digit tx or not, etc.).
- When customizing the Datalogic Standard code identifiers, 1 or 2 identifier characters can be defined for each code type. If only 1 identifier character is required, the second character must be selected as **FF** (disabled).
- The code identifier can be singly disabled for any code by simply selecting **FF** as the first identifier character.
- Write in the Custom character identifiers in the table above for your records.



DATA FORMAT



CODE IDENTIFIER

◆ disable



Datalogic standard



AIM standard



custom





CUSTOM CODE IDENTIFIER

define custom code identifier(s)



- ① Read the above code.
(Code Identifiers default to Datalogic standard, see table on previous page).
- ② Select the code type from the code table in Appendix A for the identifier you want to change.
- ③ You can define 1 or 2 identifier characters for each code type. If only 1 identifier character is required, the second character must be selected as **FF** (disabled). Read the hexadecimal value corresponding to the character(s) you want to define as identifiers for the code selected in step ②: valid characters are in the range **00-FD**.

Example: To define Code 39 Code Identifier = @

Read define custom code identifier(s) + Code 39 + 40 + FF



DATA FORMAT



HEADER

no header



one character header



two character header



three character header



four character header



five character header



six character header



seven character header



eight character header



After selecting **one** of the desired Header codes, read the character(s) from the HEX table.

Valid characters for all readers are in the range: **00-FE**

Example:

four character header



+ 41 + 42 + 43 + 44 = Header **ABCD**

For more details about default and WEDGE Interface Extended Keyboard values, see pars. 5.3.1 and 5.3.2.

**DATA FORMAT*****TERMINATOR***

no terminator



one character terminator



two character terminator



three character terminator



four character terminator



five character terminator



six character terminator



seven character terminator



eight character terminator



After selecting **one** of the desired Terminator codes, read the character(s) from the HEX table.

Valid characters for all readers are in the range: **00-FE**

Example:

two character terminator

+ 0D + 0A = Terminator **CR LF**

For more details about default and WEDGE Interface Extended Keyboard values, see par. 5.3.1 and 5.3.2.

**FIELD ADJUSTMENT**

◆ disable field adjustment



Field adjustment allows a number of characters n , to be added to or subtracted from the barcode read. The adjustment can be different for each enabled code type. To define the field adjustment:

- ① Read the enable field adjustment code:



enable field adjustment



- ② Select the code type from the Code Identifier Table in Appendix A.
 ③ Select the type of adjustment to perform:

right addition



left addition



right deletion



left deletion



- ④ Read a number in the range **01 - 32** from the Hex/Numeric Table to define how many characters to add or delete:

Conditions:

- Adjustment is only performed on the barcode data, the Code Identifier and Code Length Transmission fields are not modified by the field adjustment parameter.
- If the field setting would subtract more characters than exist in the barcode, the subtraction will take place only to code length 0.
- You can set up to a maximum of 10 different field adjustments on the same barcode family or on different barcode families.

Example: To add 4 characters to the right of Standard Code 39 Codes:

Read  +  +  + **04**



DATA FORMAT

FIELD ADJUSTMENT CHARACTER

- ① Read the field adjustment character code:



field adjustment character



- ② Read the hexadecimal value corresponding to the character you want to use for field adjustment.

Valid characters for all readers are in the range: **00-FE**

Example:

To define the field adjustment character = **A**:

Read field adjustment character
 + 41

CODE LENGTH TX

- ◆ code length not transmitted



code length transmitted in variable-digit format



code length transmitted in fixed 4-digit format



The code length is transmitted in the message after the Headers and Code Identifier characters. The code length is *calculated* after performing any field adjustment operations.



CHARACTER REPLACEMENT

◆ disable character replacement



This parameter allows up to three characters to be replaced from the barcode read. These substitutions are stored in memory. To define each character replacement:

- ① Read one of the following character replacement codes:

first character replacement



second character replacement



third character replacement



- ② From the Code Identifier Table in Appendix A, read the Code Identifier for the desired code family.
0 = character replacement will be effective for all code families.
- ③ From the Hex/Numeric Table read two characters corresponding to the Hex value which identifies the character to be replaced. Valid values for all readers are in the range **00-FE**.
- ④ From the Hex/Numeric Table read two characters corresponding to the Hex value which identifies the new character to replace. Valid values for all readers are in the range **00-FE**.
FF = the character to be replaced will be substituted with no character, that is, it will be removed from the code.

DATA FORMAT

Example:

The following strings define:

1. *First Character Replacement:* substitution in *Code 39 barcodes* of all occurrences of the **0** character with the **1** character.
2. *Second Character Replacement:* substitution in *Code 39 barcodes* of all occurrences of the **A** character with the **B** character.

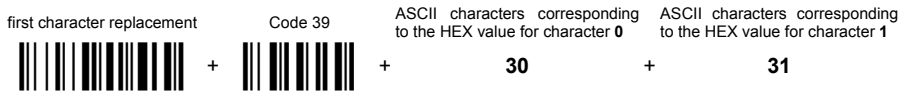

For Code 39 codes containing the string "0123", the contents transmitted will be "1123".

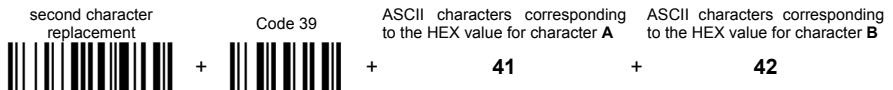

For Code 39 codes containing the string "ABCD", the contents transmitted will be "BBCD".



NO READ CHARACTER

disable



enable



- ① Read the “**enable**” code above:
- ② Read the hexadecimal value corresponding to the character you want to use for no read character.

Valid characters for all readers are in the range: **00-FE**

Example:

To define the no read character = **A**:

Enable No Read Character



+

ASCII characters corresponding to
the HEX value for character **A****41**

◆ no read character = <CAN>

POWER SAVE

⊙	<i>READ RATE</i>	⊙
⊙	<i>SLEEP STATE</i>	⊙
⊙	<i>ENTER SLEEP TIMEOUT</i>	⊙
⊙	<i>STANDBY</i>	⊙

1. Read the **Enter Configuration** code ONCE, available at the top of each page.
2. Read configuration codes from the desired groups.
 -  = Read the code and follow the procedure given
 - ◆ = Default value
3. Read the **Exit and Save Configuration** code ONCE, available at the top of each page.



POWER SAVE

READ RATE

67 reads per sec.



135 reads per sec.



◆ 270 reads per sec.



A lower read rate reduces power consumption but can lengthen reading response time.

SLEEP STATE

◆ disable



enable



See par. 5.4.1 for details.



POWER SAVE

ENTER SLEEP TIMEOUT



enter sleep timeout



Read 2 numbers in the range 00-99:

00 = Enter Sleep state immediately

01-99 = corresponds to a max. 9.9 sec. delay before entering the Sleep state.

◆ enter sleep timeout = 0.6 sec

See par. 5.4.2 for details.

STANDBY

◆ disable



optimize for reading speed

enable



optimize for low power consumption

See par. 5.4.3 for details.

READING PARAMETERS

⊙	OPERATING MODE	⊙
⊙	BEEPER INTENSITY	⊙
⊙	BEEPER TONE	⊙
⊙	BEEPER TYPE	⊙
⊙	BEEPER LENGTH	⊙
⊙	PDF DECODING RECOGNITION INTENSITY	⊙

1. Read the **Enter Configuration** code ONCE, available at the top of each page.

2. Read configuration codes from the desired groups.

 = Read the code and follow the procedure given

◆ = Default value

3. Read the **Exit and Save Configuration** code ONCE, available at the top of each page.



OPERATING MODE

serial on-line



◆ on-line



automatic



automatic / lighting system standby



The following two commands carry out their specific function and then exit the configuration environment.

enable test mode



disable test mode



See par. 5.5.1 for details.



READING PARAMETERS

BEEPER INTENSITY

* very low intensity



low intensity



medium intensity



◆ high intensity



* This sets the beeper OFF for data entry, while for all other beeper signals it has the meaning very low intensity.

BEEPER TONE

tone 1



◆ tone 2



tone 3



tone 4





READING PARAMETERS



BEEPER TYPE

◆ monotone



bitonal



BEEPER LENGTH

long



◆ short



PDF DECODING RECOGNITION INTENSITY

◆ low



high



DECODING PARAMETERS

⊙	INK-SPREAD	⊙
⊙	OVERFLOW CONTROL	⊙
⊙	INTERDIGIT CONTROL	⊙
⊙	DECODING SAFETY	⊙
⊙	PUZZLE SOLVER™	⊙



CAUTION

Before changing these parameter values read the descriptions in par. 5.6.

- 1.** Read the **Enter Configuration** code ONCE, available at the top of each page.
- 2.** Read configuration codes from the desired groups.
◆ = Default value
- 3.** Read the **Exit and Save Configuration** code ONCE, available at the top of each page.



DECODING PARAMETERS



INK-SPREAD

disable



◆ enable



See par. 5.6.1 for details.

OVERFLOW CONTROL

disable



◆ enable



See par. 5.6.2 for details.



DECODING PARAMETERS

INTERDIGIT CONTROL

disable



◆ enable



See par. 5.6.3 for details.

DECODING SAFETY

◆ one read



(decoding safety disabled)

two reads



three reads



four reads



Required number of good reads before accepting code.



DECODING PARAMETERS



PUZZLE SOLVER™

◆ disable



enable



In the case of damaged or poorly printed codes, this parameter allows reading multiple parts of the single code to reconstruct it.

To read codes using this technology, simply move the illuminated bar over the code so that each line of the code is scanned. During this process a series of brief "ticks" indicates that reading is proceeding correctly.

Conditions:

- This parameter is only valid for the following codes:

EAN 8 without Add-on	EAN 13 without Add-on	UPC A without Add-on
Code 128	Code 39	

- Codablock-A and Codablock-F codes are automatically disabled.
- For Code 39, Check digit control without transmission is forced.
- PuzzleSolver™ is disabled when code ISBT 128 is enabled.

CODE SELECTION

<input type="radio"/>	<i>EAN/UPC FAMILY</i>	<input type="radio"/>
<input type="radio"/>	<i>2/5 FAMILY</i>	<input type="radio"/>
<input type="radio"/>	<i>CODE 39 FAMILY</i>	<input type="radio"/>
<input type="radio"/>	<i>CODE 128 FAMILY</i>	<input type="radio"/>
<input type="radio"/>	<i>CODABAR FAMILY</i>	<input type="radio"/>
<input type="radio"/>	<i>CODE 93</i>	<input type="radio"/>
<input type="radio"/>	<i>CODE 16K</i>	<input type="radio"/>
<input type="radio"/>	<i>CODABLOCK-A</i>	<input type="radio"/>
<input type="radio"/>	<i>CODABLOCK-F</i>	<input type="radio"/>
<input type="radio"/>	<i>MSI</i>	<input type="radio"/>
<input type="radio"/>	<i>PLESSEY</i>	<input type="radio"/>
<input type="radio"/>	<i>TELEPEN</i>	<input type="radio"/>
<input type="radio"/>	<i>DELTA IBM</i>	<input type="radio"/>
<input type="radio"/>	<i>CODE 49</i>	<input type="radio"/>
<input type="radio"/>	<i>PHARMACODE</i>	<input type="radio"/>
<input type="radio"/>	<i>PDF417</i>	<input type="radio"/>

1. Read the **Enter Configuration** code ONCE, available at the top of each page.
2. Read configuration codes from the desired groups.
 -  = Read the code and follow the procedure given
 - ◆ = Default value
3. Read the **Exit and Save Configuration** code ONCE, available at the top of each page.



CODE SELECTION

DISABLE ALL CODE FAMILIES



NOTE

The reader allows up to 5 code selections. This does not limit the number of CODES enabled to 5, as it depends on the code family.

SINGLE SELECTIONS =

- ONE combination code from the EAN family
- ONE code from the 2/5 family

Example

5 code selections:

1. **2/5 Interleaved**
2. **2/5 Industrial**
3. Code 128 + EAN 128
4. Code 39 Full ASCII + Code 32
5. **UPC A/UPC E**

In this section all **SINGLE** code selections are **underlined and in bold.**

**CODE SELECTION**

EAN/UPC FAMILY

disable the family



- ① Read the desired family code

Note:

Since the EAN/UPC without ADD ON code selection is enabled by default, to correctly enable another selection, first disable the family.

EAN 8/EAN 13/UPC A/UPC E with and without ADD ON

WITHOUT ADD ON**◆ EAN 8/EAN 13/UPC A/UPC E****EAN 8/EAN 13****UPC A/UPC E**



CODE SELECTION

WITH ADD ON 2 AND 5

EAN 8/EAN 13/UPC A/UPC E



EAN 8/EAN 13



UPC A/UPC E



WITH ADD ON 2 ONLY

EAN 8/EAN 13



UPC A/UPC E



WITH ADD ON 5 ONLY

EAN 8/EAN 13



UPC A/UPC E





CODE SELECTION

EAN/UPC CHECK DIGIT TX SELECTIONS

For each code type in this family you can choose to transmit the check digit or not

CHECK DIGIT TRANSMISSION

◆ EAN 8



◆ EAN 13



◆ UPC A



◆ UPC E



NO CHECK DIGIT TRANSMISSION

EAN 8



EAN 13



UPC A



UPC E





CODE SELECTION

CONVERSION OPTIONS

UPC E to UPC A conversion



UPC E to EAN 13 conversion



UPC A to EAN 13 conversion



EAN 8 to EAN 13 conversion



Enable only ISBN conversion



Enable only ISSN conversion



Enable both ISBN and ISSN conversion



Disable both ISBN and ISSN conversion



**CODE SELECTION****2/5 FAMILY**

disable the family



① Read the desired family code

◆ **Interleaved 2/5****Normal 2/5 (5 Bars)****Industrial 2/5 (IATA)****Matrix 2/5 (3 Bars)**

② Read a check digit selection

CHECK DIGIT TABLE

no check digit control



◆ check digit control and transmission



check digit control without transmission

③ Read **4** numbers for the code length where:

- **First 2 digits** = minimum code length.
- **Second 2 digits** = maximum code length.

The maximum code length is **99** characters.

The minimum code length must always be less than or equal to the maximum.

Examples:

0199 = variable from 1 to 99 digits in the code.**1010** = 10 digit code length only.

The pharmaceutical code below is part of the 2/5 family but has no check digit or code length selections.

Code CIP/HR

French pharmaceutical code



CODE SELECTION

CODE 39 FAMILY

disable the family



① Read the desired family code



◆ **Standard Code 39**



Full ASCII Code 39



② Read a check digit selection

CHECK DIGIT TABLE

◆ no check digit control



check digit control
and transmission



check digit control
without transmission





CODE SELECTION

The pharmaceutical codes below are part of the Code 39 family but have no check digit selections.

Code CIP39



French pharmaceutical code

Code 32



Italian pharmaceutical code

CODE LENGTH (optional)

The code length selection is valid for the entire Code 39 family

Read the code + 4 numbers for the code length where:

First 2 digits = minimum code length.

Second 2 digits = maximum code length.

set code length



The maximum code length is **99** characters.

The minimum code length must always be less than or equal to the maximum.

Examples: **0199** = variable from 1 to 99 digits in the code. **1010** = 10 digit code length only.



CODE SELECTION

CODE 128 FAMILY

disables the family



- ① Read the desired family code

◆ Code 128



control without transmission
of check digit

EAN 128



control without transmission
of check digit

Transmit GS Before Code

Code EAN 128 uses the ASCII <GS> character to separate a variable length code field from the next code field. This character can also be transmitted before the code.

◆ disable



enable



If the <GS> character has been modified in the Character Replacement parameter, the new character is affected by this command.



CODE SELECTION

ISBT 128



Enabling ISBT 128 automatically disables Puzzle Solver™.

CODE LENGTH (optional)

The code length selection is valid for the entire Code 128 family.

Read the code + 4 numbers for the code length where:

First 2 digits = minimum code length

Second 2 digits = maximum code length

set code length



The maximum code length is 99 characters. The minimum code length must always be less than or equal to the maximum.

Examples: **0199** = variable from 1 to 99 digits in the code. **1010** = 10 digit code length only.

The length is calculated on the output string.

CODE 93

◆ disable the code



Code 93



control without transmission
of check digit



CODE SELECTION

CODABAR FAMILY

◆ disable the family



① Read the desired equality control code

② Read a start/stop transmission selection

Standard Codabar



no start/stop character equality control

START/STOP CHARACTER TRANSMISSION

no transmission



Standard Codabar



start/stop character equality control

transmission



The Codabar ABC code below uses a fixed start/stop character transmission selection.

Codabar ABC



no start/stop character equality control but transmission.



CODE SELECTION

Codabar ABC Forced Concatenation

enable Codabar ABC with forced concatenation



non start/stop character equality control but transmission

CODE LENGTH (optional)

The code length selection is valid for the entire Codabar family

Read the code + 4 numbers for the code length where:

First 2 digits = minimum code length.

Second 2 digits = maximum code length.

set code length



The maximum code length is **99** characters.

The minimum code length must always be less than or equal to the maximum.

Examples: **0199** = variable from 1 to 99 digits in the code. **1010** = 10 digit code length only.

START/STOP CHARACTER CASE IN TRANSMISSION

The start/stop character case selections below are valid for the entire Codabar family:

transmit start/stop characters in lower case



transmit start/stop characters in upper case





CODE SELECTION

CODABLOCK-A

ONLY FOR TC1100-X200

◆ disable the code



Codablock-A



Notes:

- Enabling Codablock-A automatically disables the entire Code 39 family and vice-versa.
- Enabling Codablock-A automatically disables Puzzle Solver™.

To read stacked codes, simply move the illuminated bar over the code so that each line of the code is scanned. During this process a series of brief "ticks" indicates that reading is proceeding correctly.

CODABLOCK-F

ONLY FOR TC1100-X200

◆ disable the family



Codablock-F Standard



Codablock-F EAN



Notes:

- Enabling Codablock-F automatically disables Puzzle Solver™.

To read stacked codes, simply move the illuminated bar over the code so that each line of the code is scanned. During this process a series of brief "ticks" indicates that reading is proceeding correctly.



CODE SELECTION

MSI

ONLY FOR TC1100-X100

◆ disable the family



Enable the code by selecting one of the check digit selections.

no check digit control



MOD10 check digit control
no check digit transmission



MOD10 check digit control
check digit transmission



MOD11 - MOD10 check digit control
no check digit transmission



MOD11 - MOD10 check digit control
check digit transmission



MOD10 - MOD10 check digit control
no check digit transmission



MOD10 - MOD10 check digit control
check digit transmission





CODE SELECTION

PLESSEY

ONLY FOR TC1100-X100

◆ disable the family



Enable the code by selecting one of the check digit selections.

Standard Plessey

no check digit control



check digit control
check digit transmitted



check digit control
check digit not transmitted



Anker Plessey

no check digit control



check digit control
check digit transmitted



check digit control
check digit not transmitted





CODE SELECTION

TELEPEN

ONLY FOR TC1100-X100

◆ disable the family



Enable the code by selecting one of the check digit selections.

Numeric Telepen

no check digit control



check digit control
check digit transmitted



check digit control
check digit not transmitted



Alphanumeric Telepen

no check digit control



check digit control
check digit transmitted



check digit control
check digit not transmitted





CODE SELECTION



DELTA IBM

◆ disable the family



Enable the code by selecting one of the check digit selections.

no check digit control



Type 1 check digit control



Type 2 check digit control





CODE SELECTION

CODE 16K

◆ disable the code



Code 16K



To read stacked codes, simply move the illuminated bar over the code so that each line of the code is scanned. During this process a series of brief "ticks" indicates that reading is proceeding correctly.

CODE 49

◆ disable the code



Code 49



To read stacked codes, simply move the illuminated bar over the code so that each line of the code is scanned. During this process a series of brief "ticks" indicates that reading is proceeding correctly.



CODE SELECTION

PHARMACODE

ONLY FOR TC1100-X100

◆ disable the code



- ① Enable the code by selecting one of the code tx direction.

Code Tx Direction

forward



reverse



- ② Then, read **4** numbers for the code length where:

First 2 digits = minimum code length.

Second 2 digits = maximum code length.

The minimum code length is 2 characters. The maximum code length is 99 characters.

Overflow Ratio

- ① Read the code below:

set overflow ratio



- ② Then, read **2** numbers in the range **02-10**.



CODE SELECTION

PDF417

ONLY FOR TC1100-X200

disable the code



◆ PDF417



To read stacked codes, simply move the illuminated bar over the code so that each line of the code is scanned. During this process a series of brief "ticks" indicates that reading is proceeding correctly.

5 REFERENCES

5.1 RS232 PARAMETERS

5.1.1 Handshaking

Hardware handshaking: (RTS/CTS)

The RTS line is activated by the decoder before transmitting a character. Transmission is possible only if the CTS line (controlled by the Host) is active.

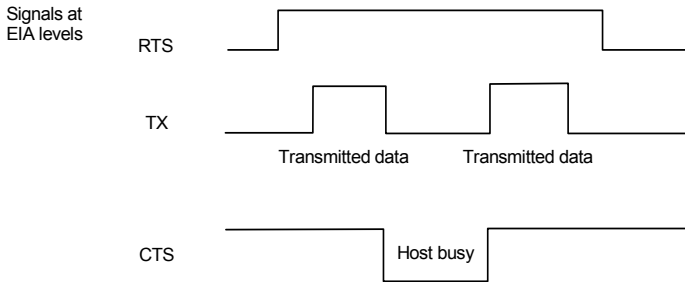

Figure 31 - RTS/CTS Handshaking

Software handshaking: (XON/XOFF)

During transmission, if the Host sends the XOFF character (13 Hex), the decoder interrupts the transmission with a maximum delay of one character and only resumes when the XON character (11 Hex) is received.

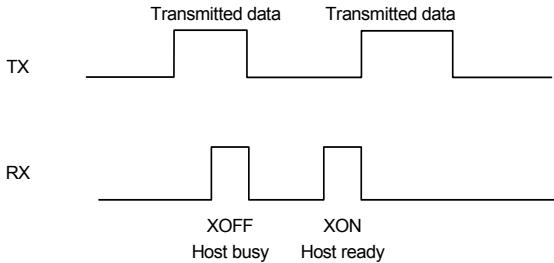

Figure 32 - XON/XOFF Handshaking

5.1.2 ACK/NACK from Host Protocol

This parameter sets a transmission protocol in which the Host responds to the reader after every code transmitted. The Host sends an ACK character (06 HEX) in the case of good reception or the NACK character (15 HEX) requesting re-transmission, in the case of bad reception.

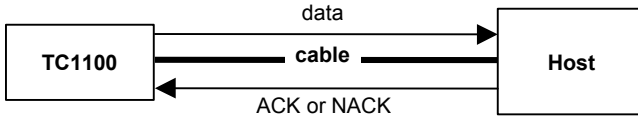

Figure 33 - ACK/NACK Enabled

5.1.3 FIFO

This parameter determines whether data (barcodes) are buffered on a First In First Out basis allowing faster data collection in certain cases for example when using slow baud rates and/or hardware handshaking.

If the FIFO buffering is enabled, codes are collected and sent out on the serial line in the order of acquisition. About 800 characters can be collected (buffer full), after which the reader signals an error and discards any further codes until the transmission is restored.

If the FIFO buffering is disabled, each code must be transmitted before another one can be read.

5.1.4 RX Timeout

When the RS232 interface is selected, the Host can be used to configure the device by sending it command strings (see chapter 3).

This parameter can be used to automatically end data reception from the Host after the specified period of time.

If no character is received from the Host, after the timeout expires, any incomplete string (any string not terminated by <CR>) is flushed from the device buffer.

5.2 PEN PARAMETERS

5.2.1 Minimum Output Pulse

This parameter sets the duration of the output pulse corresponding to the narrowest element in the barcode. In this way the code resolution is controlled by the signal sent to the decoder, independently of the physical resolution of the code read.

The shortest pulse (200 μs) corresponds to a high resolution code emulation and therefore a shorter transfer speed to the decoder (for decoders able to work on high resolution codes). Likewise, longer pulses correspond to low resolution code emulation and therefore a longer transfer time to the decoder.

5.2.2 Overflow

This parameter generates a white space before the first bar and after the last bar of the code. The selections are as follows:

- narrow = space 10 times the minimum output pulse.
- medium = space 20 times the minimum output pulse.
- wide = space 30 times the minimum output pulse.

5.2.3 Output and Idle Levels

The following state diagrams describe the different output and idle level combinations for Pen Emulation:

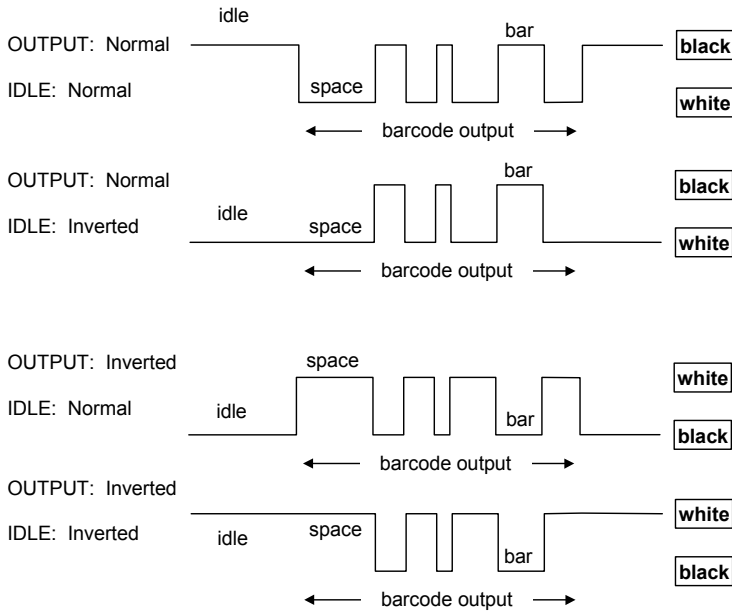

Figure 34 - Output and Idle Levels

5.2.4 Inter-Block Delay

For the PEN Emulation interface, data are sent to the Host in fixed size blocks of 20 characters each. The inter-block delay parameter allows setting a delay between each block sent to the Host.

5.3 DATA FORMAT

5.3.1 Header/Terminator Selection

The header/terminator selection is not effected by the reading of the restore default code. In fact, header and terminator default values depend on the interface selection:

RS232: no header, terminator CR-LF
 WEDGE: no header, terminator ENTER

These default values are always restored through the reading of RS232 or WEDGE interface selection code, see chapter 3.

For the WEDGE interface, the following extended keyboard values can also be configured:

EXTENDED KEYBOARD TO HEX CONVERSION TABLE				
HEX	IBM AT IBM 3153 APPLE ADB	IBM XT	IBM 31xx, 32xx, 34xx, 37xx	Wyse Digital
HEX	KEY	KEY	KEY	KEY
83	ENTER	ENTER	FIELD EXIT	RETURN
84	TAB	TAB	TAB	TAB
85	F1	F1	F1	F1
86	F2	F2	F2	F2
87	F3	F3	F3	F3
88	F4	F4	F4	F4
89	F5	F5	F5	F5
8A	F6	F6	F6	F6
8B	F7	F7	F7	F7
8C	F8	F8	F8	F8
8D	F9	F9	F9	F9
8E	F10	F10	F10	F10
8F	F11	ESC	F11	F11
90	F12	BACKSPACE	F12	F12
91	HOME	HOME	ENTER	F13
92	END	END	RESET	F14
93	PG UP	PG UP	INSERT	F15
94	PG DOWN	PG DOWN	DELETE	F16
95	↑	↑	FIELD -	UP
96	↓	↓	FIELD +	DOWN
97	←	←	ENTER (Paddle)	LEFT
98	→	→	PRINT	RIGHT
99	ESC	ESC		ESC
9A	CTRL (Right)	CTRL (Right)		CTRL (Right)
9B	Euro	Space	Space	Space

For all readers using Wedge interface, all values from 9C to FE send the Space character.

5.3.2 Set Custom Extended Header/Terminator Keys

The extended Header/Terminator keys for Wedge Interface users can be customized by defining them through a simple keyboard setting procedure.

For example, the Numeric Keypad keys can be set for use as Headers or Terminators by substituting the default extended keys using this procedure.

The type of computer or terminal must be selected before activating the keyboard setting command.

Press and release a key to set it.

Some characters may require more than one key pressed simultaneously during normal use (refer to the manual of your PC or terminal for keyboard use). The exact sequence must be indicated to the reader in this case pressing and releasing the different keys.

Example:

If one has to press the "Shift" and "4" keys simultaneously on the keyboard to transmit the character "\$" to the video, to set the "\$", press and release "Shift" then press and release "4".

Each pressed and released key must generate an acoustic signal on the reader, otherwise repress the key. Never press more than one key at the same time, even if this corresponds to the normal use of your keyboard.

Press "Backspace" to correct a wrong key entry. In this case the reader emits 2 beeps.

Note: "CAPS LOCK" and "NUM LOCK" must be off before starting the keyboard setting procedure. "SHIFT" must be repressed for each character and cannot be substituted by "CAPS LOCK".

Set Custom Extended Header/Terminator Keys



\$+FB1\$-

Enter the code above.

- If the first 4 KEYS (Shift, Alt, Ctrl, and Backspace) are not available on your keyboard, you can only substitute them with keys not used, or substitute them with each other.
- Keys 5 to 28 must be defined

Press the desired keys in the following order:

The reader signals the end of the procedure with 2 beeps indicating the keys have been registered.

CUSTOM EXTENDED KEYBOARD SETTING TABLE		
		Custom
Order	HEX	KEY
01	-	Shift
02	-	Alt
03	-	Ctrl
04	-	Backspace
05	83	
06	84	
07	85	
08	86	
09	87	
10	88	
11	89	
12	8A	
13	8B	
14	8C	
15	8D	
16	8E	
17	8F	
18	90	
19	91	
20	92	
21	93	
22	94	
23	95	
24	96	
25	97	
26	98	
27	99	
28	9A	

5.4 POWER SAVE

5.4.1 Sleep State

This mode allows the μ P in the reader to enter a "Sleep" state for minimum power consumption. This command is only valid when On-Line is selected.

Before entering Sleep mode, the following are verified:

- no commands coming from Host
- no data being transmitted to Host
- Enter Sleep Timeout ended

To exit Sleep mode press the trigger.

Enabling the Sleep state implements Standby mode for CCD devices.

5.4.2 Enter Sleep Timeout

For readers that have the Sleep state enabled, this timeout determines when the reader will enter this state.

5.4.3 Standby

If this command is enabled, part of the CCD circuitry shuts down (Standby), in order to optimize low power consumption when not reading. When the trigger is pressed this circuitry powers up. This mode causes a minor delay of about 100 ms before the reader is ready.

5.5 READING PARAMETERS

5.5.1 Operating Modes

This group of parameters allows setting different reading modes:

- ON-LINE: the TC1100 reader is connected to an external Presence Sensor using EXT TRIG+ and EXT TRIG- inputs. During the active phase of the presence sensor, the TC1100 tries to acquire and correctly decode the code. If the operation is successful, the barcode characters are transmitted on the serial interface in the format defined by the current configuration. Otherwise a No Read message is sent: by default the **<CAN>** symbol is sent;

- **AUTOMATIC:** the TC1100 reader does not require connections with external presence sensors in this operating mode. In this mode the illuminator is always ON and TC1100 is continuously scanning. The reading phase is enabled when a barcode enters the reading zone of the camera and is terminated after a fixed number of scans without a code. The next reading phase will begin when a code enters the reading zone again.
The number of scans without a code is an optimized value for the CCD camera in order to improve code identification in the reading zone. Code transmission occurs as in the other operating modes but in case of No Read condition there is no transmission on the serial port.
- **AUTOMATIC / Lighting System Standby:** this mode should be used when working with sufficient ambient light. In this Automatic mode the illuminator is OFF while the CCD remains active and exploits the ambient light to detect whether a barcode enters the reading zone of the camera. If a barcode is detected, then the lighting system automatically turns on and the reading phase is enabled. Thus, this mode allows increasing the lighting system life when the Automatic mode is required.
- **SERIAL ON-LINE:** the reading phase starts when the Serial Start Character is received on the serial interface and ends when the code is read or a Serial Stop Character is received. If decoding is correct, the data is transmitted on the serial port as defined by the configuration. Otherwise a No Read message is sent: it is fixed as the **CAN** symbol. The Start and Stop characters are also fixed:
Serial START: STX
Serial STOP: ETX
- **TEST MODE:** test mode allows verifying the reader position and the associated reading features. The code is continuously read when in this mode. After 400 ms, the values relative to an internal counter and the decoded code are displayed and transmitted on the serial interface.
The counter reports a statistical calculation which consists of a good reading percentage of the total acquisitions.

The following message could be displayed:

Counter value	Code
090%	12345ABC

If the CCD reader cannot decode a label, the following message will be displayed:

0%.

Only one barcode label must be read for each reading cycle.

**NOTE**

Since Test Mode is basically a diagnostic mode, it can **only** be enabled at run time and not saved to a non-volatile memory. For the same reason, this operating mode must be disabled **only** via RS232 interface by selecting another Operating Mode command, if you want to restore the previous state of the reader.

5.5.2 Reads per Cycle

In general, a **reading cycle** corresponds to the Phase ON / Phase OFF times of a device.

The resulting effects of this parameter on code reading depend on other related configuration conditions. Here are the definitions of Phase ON and Phase OFF times.

When **one read per cycle** is selected, the device decodes only one code during the Phase ON period and immediately turns to the Phase OFF. It is only possible to read another code when the next Phase ON time occurs.

In **multiple reads per cycle**, the Phase ON period is extended so that the device can continue decoding codes until an OFF event occurs.

5.6 DECODING PARAMETERS

**CAUTION**

These parameters are intended to enhance the decoding capability of the reader for particular applications. Used incorrectly, they can degrade the reading performance or increase the possibility of a decoding error.

5.6.1 Ink-Spread

The ink-spread parameter allows the decoding of codes which are not perfectly printed because the page texture tends to absorb the ink.

5.6.2 Overflow Control

The overflow control parameter can be disabled when decoding codes printed on small surfaces, which don't allow the use of an overflow space.

This command does not effect code families 2/5, Code 128 and Code 93.



This command is forced (enabled) when PDF417 codes are enabled.

5.6.3 Interdigit Control

The interdigit control parameter verifies the interdigit spacing for code families Code 39 and Codabar.

5.7 CONFIGURATION EDITING COMMANDS

The following commands carry out their specific function and then exit the configuration environment.

Command	Description
	Restore TC1100 reader default configuration (see par. 3.1 for default settings).
	Transmit the TC1100 software release (not for PEN Emulation)
	Transmit TC1100 reader configuration in readable format (not for PEN Emulation)

6 TECHNICAL FEATURES

ELECTRICAL FEATURES	
Supply voltage	5 Vdc \pm 5%
Power consumption	1.5 W
Interfaces	RS232, Wedge, PEN Emulation
LED Indicators	Power ON / Power OFF / Good Read / Miss Read
OPTICAL FEATURES	
Sensor	CCD solid state
Max read rate	270 read/sec
Reading field	See diagrams on page 115
Max. resolution	0.076 mm (3 mils)
ENVIRONMENTAL FEATURES	
Working temperature	0° to +40 °C / +32° to +104 °F
Storage temperature	-20° to +70 °C / -4° to +158 °F
READING FEATURES	
Readable codes:	EAN/UPC Code 39 2/5 family Codabar Code 128 EAN 128 ISBT 128 Code 93 Pharmaceutical codes Telepen (TC1100-x100 only) MSI (TC1100-x100 only) Plessey (TC1100-x100 only) Delta IBM Code 16K Code 49 Pharmacode (TC1100-x100 only) Codablock-A (TC1100-x200 only) Codablock-F Std (TC1100-x200 only) Codablock-F EAN (TC1100-x200 only) PDF417 (TC1100-x200 only)
MECHANICAL FEATURES	
Dimensions (LxWxH)	60.5 x 63 x 27 mm / 2.38 x 2.48 x 1.06 in

READING DIAGRAMS

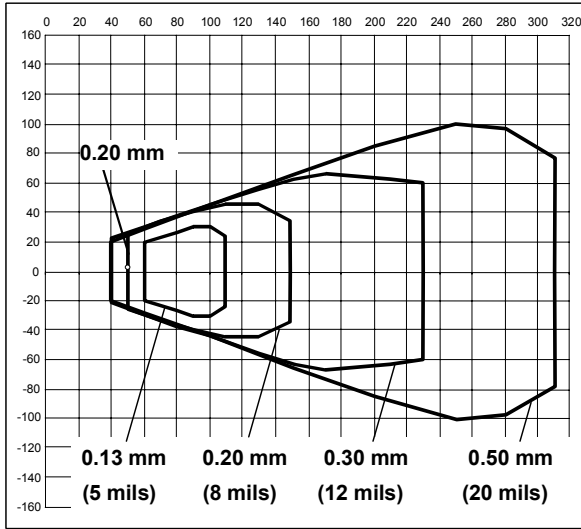

Reading Diagram TC1100-0100 (code 39)

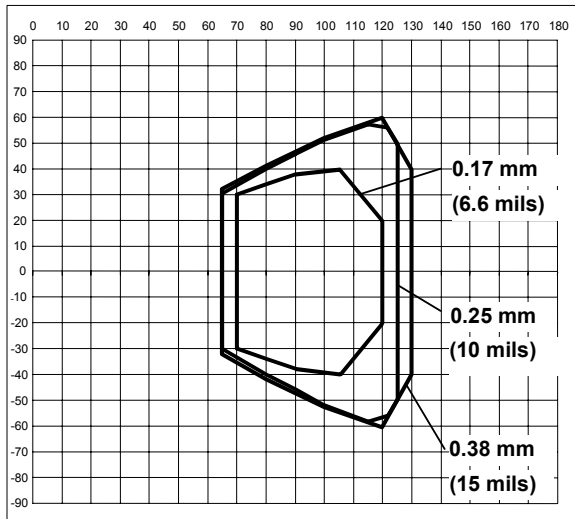

Reading Diagram TC1100-0200 (PDF417)

Figure 35 - TC1100 Scan Engine Reading Diagrams

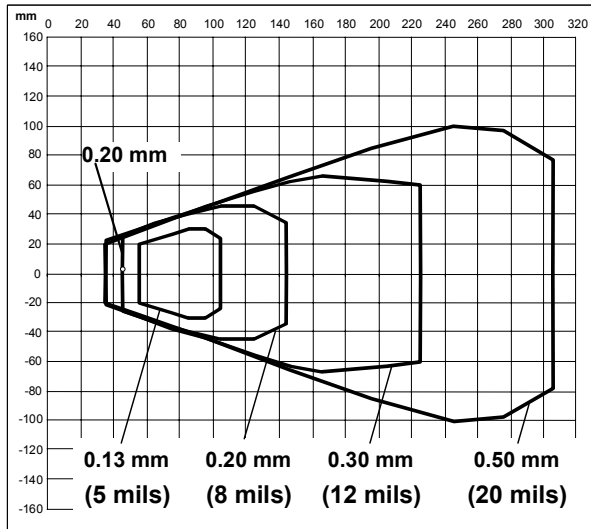

Reading Diagram TC1100-1100 (code 39)

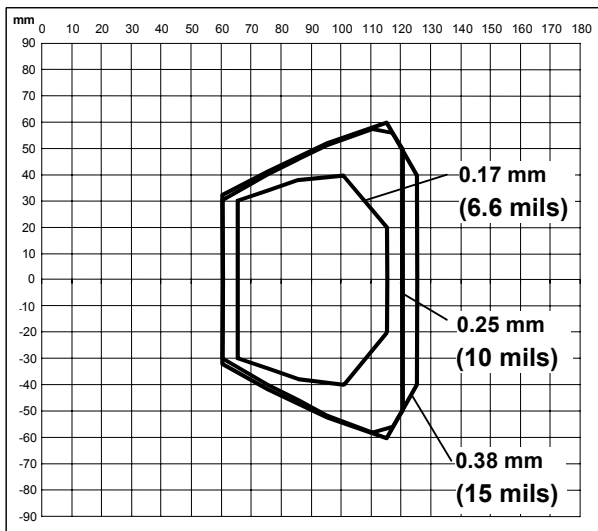

Reading Diagram TC1100-1200 (PDF417)

Figure 36 - TC1100 Scanner Reading Diagrams

A CODE IDENTIFIER TABLE

2/5 Interleaved



2/5 Industrial



2/5 normal 5 bars



2/5 matrix 3 bars



EAN 8



EAN 13



UPC A



UPC E



EAN 8 with 2 ADD ON



EAN 8 with 5 ADD ON



EAN 13 with 2 ADD ON



EAN 13 with 5 ADD ON



UPC A with 2 ADD ON



UPC A with 5 ADD ON



UPC E with 2 ADD ON



UPC E with 5 ADD ON



Code 39



Code 39 Full ASCII



CODABAR



ABC CODABAR



Code 128



EAN 128



Code 93



CIP/39



CIP/HR



Code 32



ISBT 128



CODABLOCK-F Standard



MSI



Plessey Standard



Telepen



PDF417



Pharmacode



CODABLOCK-A



CODABLOCK-F EAN



Plessey Anker



Delta IBM



Code 16K



Code 49



B HEX AND NUMERIC TABLE

**OPEN THIS PAGE TO READ THE DESIRED
HEX AND NUMERIC SELECTIONS**

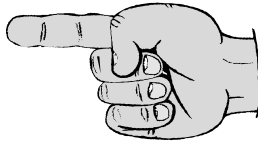

CHARACTER TO HEX CONVERSION TABLE					
char	hex	char	hex	char	hex
NUL	00	*	2A	U	55
SOH	01	+	2B	V	56
STX	02	,	2C	W	57
ETX	03	-	2D	X	58
EOT	04	.	2E	Y	59
ENQ	05	/	2F	Z	5A
ACK	06	0	30	[5B
BEL	07	1	31	\	5C
BS	08	2	32]	5D
HT	09	3	33	^	5E
LF	0A	4	34	~	5F
VT	0B	5	35	a	61
FF	0C	6	36	b	62
CR	0D	7	37	c	63
SO	0E	8	38	d	64
SI	0F	9	39	e	65
DLE	10	:	3A	f	66
DC1	11	;	3B	g	67
DC2	12	<	3C	h	68
DC3	13	=	3D	i	69
DC4	14	>	3E	j	6A
NAK	15	?	3F	k	6B
SYN	16	@	40	l	6C
ETB	17	A	41	m	6D
CAN	18	B	42	n	6E
EM	19	C	43	o	6F
SUB	1A	D	44	p	70
ESC	1B	E	45	q	71
FS	1C	F	46	r	72
GS	1D	G	47	s	73
RS	1E	H	48	t	74
US	1F	I	49	u	75
SPACE	20	J	4A	v	76
!	21	K	4B	w	77
"	22	L	4C	x	78
#	23	M	4D	y	79
\$	24	N	4E	z	7A
%	25	O	4F	{	7B
&	26	P	50		7C
'	27	Q	51	}	7D
(28	R	52	~	7E
)	29	S	53	DEL	7F
		T	54		

HEX / NUMERIC TABLE



0



2



4



6



8



A



C



E



1



3



5



7



9



B



D



F

Backspace



Cancels an incomplete configuration sequence

**Datalogic Automation S.r.l.,
Via S. Vitalino 13
40012 - Lippo di Calderara
Bologna - Italy**

dichiara che
declares that the
déclare que le
bescheinigt, daß das Gerät
declare que el

TC1100-XXXX Compact CCD Reader;

e tutti i suoi modelli
and all its models
et tous ses modèles
und seine Modelle
y todos sus modelos

sono conformi alle Direttive del Consiglio Europeo sottoelencate:
are in conformity with the requirements of the European Council Directives listed below:
sont conformes aux spécifications des Directives de l'Union Européenne ci-dessous:
der nachstehend angeführten Direktiven des Europäischen Rats:
cumple con los requisitos de las Directivas del Consejo Europeo, según la lista siguiente:

89/336/EEC EMC Directive	e and et und y	92/31/EEC, 93/68/EEC	emendamenti successivi further amendments ses successifs amendements späteren Abänderungen sucesivas enmiendas
---------------------------------	----------------------------	-----------------------------	--

Basate sulle legislazioni degli Stati membri in relazione alla compatibilità elettromagnetica ed alla sicurezza dei prodotti.

On the approximation of the laws of Member States relating to electromagnetic compatibility and product safety.

Basée sur la législation des Etats membres relative à la compatibilité électromagnétique et à la sécurité des produits.

Über die Annäherung der Gesetze der Mitgliedsstaaten in bezug auf elektromagnetische Verträglichkeit und Produktsicherheit entsprechen.

Basado en la aproximación de las leyes de los Países Miembros respecto a la compatibilidad electromagnética y las Medidas de seguridad relativas al producto.

Questa dichiarazione è basata sulla conformità dei prodotti alle norme seguenti:

This declaration is based upon compliance of the products to the following standards:

Cette déclaration repose sur la conformité des produits aux normes suivantes:

Diese Erklärung basiert darauf, daß das Produkt den folgenden Normen entspricht:

Esta declaración se basa en el cumplimiento de los productos con las siguientes normas:

**EN 55022 (Class B ITE), August 1994:
AMENDMENT A1 (CLASS B ITE), October 2000**

LIMITS AND METHODS OF MEASUREMENTS OF RADIO DISTURBANCE
CHARACTERISTICS OF INFORMATION TECHNOLOGY EQUIPMENT

EN 61000-6-2, October 2001:

ELECTROMAGNETIC COMPATIBILITY (EMC).
PART 6-2: GENERIC STANDARDS – IMMUNITY FOR INDUSTRIAL
ENVIRONMENTS

Lippo di Calderara, April 2nd, 2007

Lorenzo Girotti
Product & Process Quality Manager

