



## S80-MH-5-Y09

Distance sensor with laser emission and time of flight measurement

### INSTRUCTION MANUAL



### CONTROLS

#### FRONT INDICATORS LED

#### OUTPUT LED

The yellow LED ON indicates the OR function of the OUT1 and OUT2 outputs (one of the 2 outputs is active).

#### ALARM LED

The red LED ON indicates the absence of signal.

#### COMMAND PANEL AND DISPLAY

#### OUTPUT LED

The yellow LED ON indicates the logic OR function of the two OUT1 and OUT2 outputs (one of the 2 outputs is active).

#### DISPLAY (4-digit green coloured display)

In the normal mode, the display indicates the detected distance, in millimetres.

The "LLLL" message on display means distance under the minimum value.

The "HHHH" message on display means distance over the maximum value.

The "FFFF" message on display means low signal received condition.

#### OUT1, OUT2 LEDs

The n.1 and n.2 green LEDs ON indicate the activation of the OUT1 and OUT2 outputs.

#### FAST LED

The n.3 green LED ON indicates the activation of the FAST reading mode (500 Hz).

#### SET PUSHBUTTON

A pressure on the pushbutton activates the self-setting procedure.

A long pressure on the pushbutton allows the user to access into the mode (FAST or NORM) and delay setting menu.

#### +/- PUSHBUTTONS

A light pressure on these pushbuttons allows the user to run through the menu of the sensor parameters and setting menu.

Moreover, a long pressure allows to change the switching threshold value, as indicated in the "SWITCHING THRESHOLD ADJUSTMENT" paragraph.

### INSTALLATION

The sensor can be positioned by means of the three housing's holes using screws (M5x40 or longer) with nuts and washers.

Various orientable fixing brackets to ease the sensor positioning are available (please refer to the accessories listed in the catalogue).

The operating distance is measured from the front surface of the sensor optics.

The M12 connector can be oriented at two different positions (refer to figure).



### CONNECTIONS

#### M12 CONNECTOR

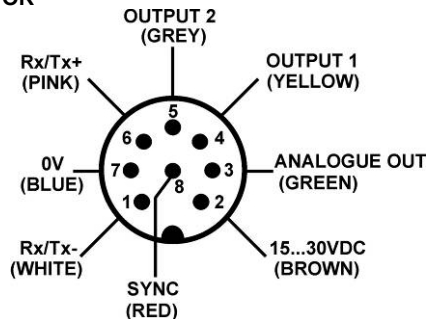

NOTE: the wire colours are referred to the cables manufactured according to the European standard.

### TECHNICAL DATA

Power supply:	15 ... 30 Vdc limit values
Ripple:	2 Vpp max.
Consumption (output current excluded):	170 mA max (110 mA @ 24 V)
Outputs:	2 PNP or NPN outputs 30 Vdc max. (short-circuit protection) analogue output with 4-20 mA
Serial interface:	RS485, 9600Bd, 8N1
SYNC input:	PNP
Measurement range:	300 ... 4000 mm (from 90% white to 18% grey) 400 ... 2500 mm (6% black)
Linearity:	0.3% (24Vdc, 25°C, with 90% white target)
Repeatability:	3 mm @ 4m (NORM) / 5 mm @ 4m (FAST)
Digital resolution:	0.9 mm
Hysteresis:	5 mm (NORM) ; 10 mm (FAST)
Temperature drift:	< 0.6 mm/°C
Output current:	100 mA max.
Output saturation voltage:	≤ 2 V
Response time:	5 ms (NORM) ; 1 ms (FAST)
Switching frequency:	100 HZ (NORM) ; 500 HZ (FAST)
Indicators:	<i>command panel:</i> 4-digit display (GREEN), OUTPUT LED (YELLOW) 2 OUT1, OUT2 LEDs (GREEN) FAST LED (GREEN). <i>Indicators LED:</i> OUTPUT LED (YELLOW) / ALARM LED (RED)
Setting:	SET, +, - pushbuttons
Data retention:	non volatile EEPROM memory
Operating temperature:	-10 ... 50 °C
Storage temperature:	-20 ... 70 °C
Electrical shock protection:	Class 2
Typical spot dimension:	∅ 12 mm at 2 m ∅ 20 mm at 4 m
Emission type:	Red laser (665 nm) Class 2 (∅. 665 nm) EN 60825-1 (1994)
Ambient light rejection:	According to EN 60947-5-2
Vibrations:	0.5 mm amplitude, 10 ... 55 Hz frequency, for every axis (EN60068-2-6)
Shock resistance:	11 ms (30 G) 6 shock for every axis (EN60068-2-27)
Housing material:	aluminium
Lens material:	Window and lenses in glass
Mechanical protection:	IP67
Connections:	M12-8 pole connector
Weight:	330 g. max.

### DIMENSIONS

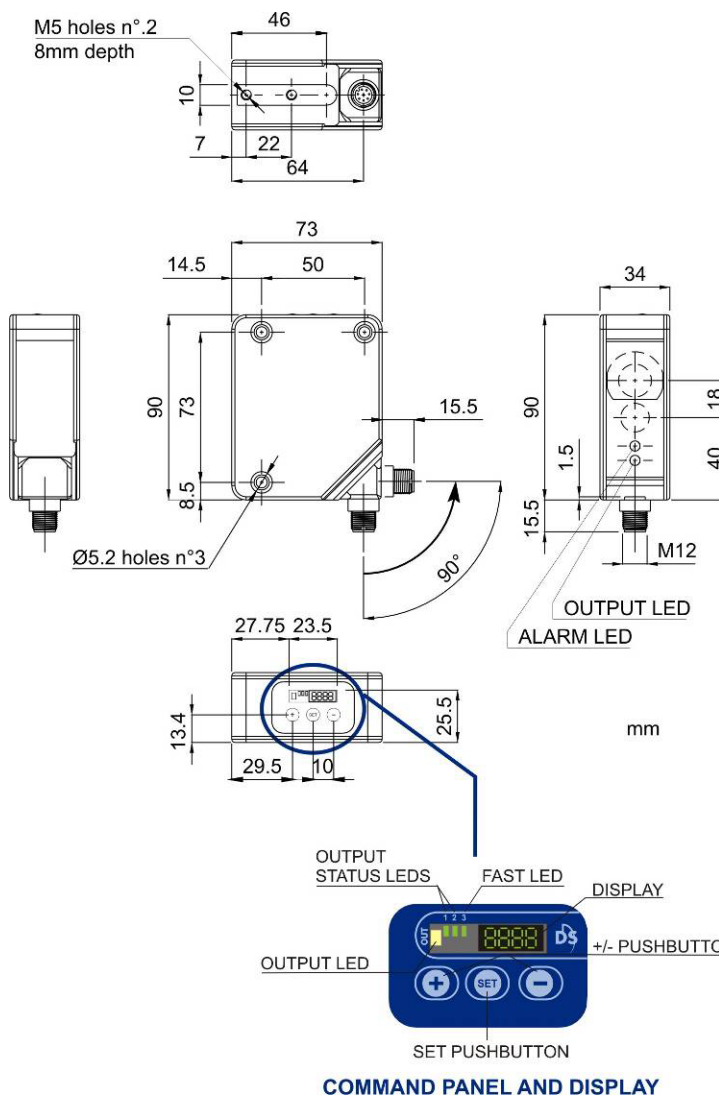

### SETTING OF THE 2 CHANNELS

**Legend:** ● pushbutton pressed ○ pushbutton not pressed  
■ LED on □ LED off

The switching threshold setting for each of the 2 channels and the selection of the logic switching is effected placing directly the object to detect in front of the sensor, according to the following procedure:

#### - Detection

- Place the object to detect in front of the sensor.

	OUT				Display				Keyboard		
OR	1	2	3	Dig1	Dig2	Dig3	Dig4	+	SET	-	
■	□	■	□	1	9	4	5	○	●	○	

- Press the SET pushbutton for at least 2 s.

- The "CH-1" message appears.

OR	1	2	3	Dig1	Dig2	Dig3	Dig4	+	SET	-
□	□	□	□	C	H	-	1	○	●	○

#### - Channel selection

- To select the channel setting use the +/- pushbuttons.

OR	1	2	3	Dig1	Dig2	Dig3	Dig4	+	SET	-
□	□	□	□	C	H	-	1	●	○	●

#### - DARK/LIGHT selection

- Press the SET pushbutton again for at least 0.5 s.

- The "L On" message appears.

OR	1	2	3	Dig1	Dig2	Dig3	Dig4	+	SET	-
□	□	□	□	L	O	n	○	●	○	○

- To select the DARK/LIGHT mode of the channel use the +/- pushbuttons.

- "L on" is visualised when the LIGHT mode is selected; "d On" in case of DARK mode

OR	1	2	3	Dig1	Dig2	Dig3	Dig4	+	SET	-
□	□	□	□	L	O	n	○	●	○	●

#### - Target detection phase

- Press the SET pushbutton for at least 0.5 s, the "uPdt" message begins to blink (4Hz, for 2 s).

OR	1	2	3	Dig1	Dig2	Dig3	Dig4	+	SET	-
□	□	□	□	u	P	d	t	○	●	○

- The detection distance value appears.

- The +/- pushbuttons can be used to change the detected distance value.

OR	1	2	3	Dig1	Dig2	Dig3	Dig4	+	SET	-
■	□	■	□	1	9	4	5	●	○	●

- The units change if these pushbuttons are pressed repeatedly, the tens if kept pressed.

- Press the SET pushbutton again for at least 0.5 s. to end the detection phase.

OR	1	2	3	Dig1	Dig2	Dig3	Dig4	+	SET	-
■	□	■	□	1	9	4	5	○	●	○

### SWITCHING THRESHOLD ADJUSTMENT

	OUT				Display				Keyboard		
OR	1	2	3	Dig1	Dig2	Dig3	Dig4	+	SET	-	
■	□	■	□	1	9	4	5	●	○	●	

- Press the +/- pushbuttons for at least 2 s.

- The "CH-1" message appears.

OR	1	2	3	Dig1	Dig2	Dig3	Dig4	+	SET	-
■	□	■	□	C	H	-	1	○	○	○

#### - Channel selection

- Use the +/- pushbuttons to select the channel to detect.

OR	1	2	3	Dig1	Dig2	Dig3	Dig4	+	SET	-
■	□	■	□	C	H	-	2	●	○	●

#### - Distance of threshold phase

- Press the SET pushbutton for at least 0.5 s.

- The previously detected distance value appears.

- Use the +/- pushbuttons to change the detected distance value.

- The units change if these pushbuttons are pressed repeatedly, the tens if kept pressed.

OR	1	2	3	Dig1	Dig2	Dig3	Dig4	+	SET	-
■	□	■	□	1	9	4	5	●	○	●

- Press the SET pushbutton again for at least 0.5 s. to end the adjustment phase.

OR	1	2	3	Dig1	Dig2	Dig3	Dig4	+	SET	-
■	□	■	□	1	9	6	0	○	●	○

### SETTING OF THE PARAMETERS

	OUT				Display				Keyboard		
OR	1	2	3	Dig1	Dig2	Dig3	Dig4	+	SET	-	
□	□	□	□	1	9	4	5	○	●	○	

Press the SET pushbutton for at least 6 s to enter into the parameter setting menu.

The "MEnu" message appears.

OR	1	2	3	Dig1	Dig2	Dig3	Dig4	+	SET	-
□	□	□	□	M	E	n	u	○	○	○

Pressing the + and - pushbuttons the user and run up and down the menu, reading the following messages.

#### - Functioning mode selection

- At each pressure of the SET pushbutton, the user can run through the options of the selected level.

OR	1	2	3	Dig1	Dig2	Dig3	Dig4	+	SET	-
□	□	□	□	n	O	r	M	○	○	○

F	A	S	t	○	●	○
---	---	---	---	---	---	---

- The setting of the normal of fast mode is in common to both outputs.

#### - Delay setting

- At each pressure of the SET pushbutton, the user can run through the options of the selected level.

OR	1	2	3	Dig1	Dig2	Dig3	Dig4	+	SET	-
□	□	□	□	d	-	0	0	○	○	○

d	-	0	5	○	●	○
---	---	---	---	---	---	---

d	-	1	0	○	●	○
---	---	---	---	---	---	---

d	-	2	0	○	●	○
---	---	---	---	---	---	---

d	-	3	0	○	●	○
---	---	---	---	---	---	---

d	-	4	0	○	●	○
---	---	---	---	---	---	---

- The delay value setting is in common to both outputs.

- When a delay value, different from zero, is set, the outputs will be maintained active for a minimum time equal to the number of milliseconds visualised on the display.

#### - Visualisation of the channel 1 data

- At each pressure of the SET pushbutton, the user can run through the options of the selected level.

OR	1	2	3	Dig1	Dig2	Dig3	Dig4	+	SET	-
□	□	□	□	C	H	-	1	○	○	○

THRESHOLD	1	9	4	5	○	●	○
-----------	---	---	---	---	---	---	---

MODE	L/d	-	O	n	○	●	○
------	-----	---	---	---	---	---	---

#### - Visualisation of the channel 2 data

At each pressure of the SET pushbutton, the user can run through the options of the selected level.

OR	1	2	3	Dig1	Dig2	Dig3	Dig4	+	SET	-
□	□	□	□	C	H	-	2	○	○	○

THRESHOLD	1	9	4	5	○	●	○
-----------	---	---	---	---	---	---	---

MODE	L/d	-	O	n	○	●	○
------	-----	---	---	---	---	---	---

#### - Serial output deactivation

At each pressure of the SET pushbutton, the user can run through the options of the selected level.

OR	1	2	3	Dig1	Dig2	Dig3	Dig4	+	SET	-
□	□	□	□	S	-	o	f	○	○	○

S	-	o	f	○	●	○
---	---	---	---	---	---	---

#### - Memorisation of the parameters set

OR	1	2	3	Dig1	Dig2	Dig3	Dig4	+	SET	-
□	□	□	□	S	A	V	E	○	○	○

S	A	V	E	○	●	○
---	---	---	---	---	---	---

- Pressing the SET pushbutton (the SAVE message blinks for 2s, 4Hz) all the changed values are saved and the user exits from the menu, and returns to the normal mode.  
- One of the +/- pushbuttons has to be pressed to return to the setting menu.

#### - Exit from the parameter setting menu

After a 10 s inactivity of the pushbuttons, the sensor returns to the normal mode visualising the distance.

## REMOTE FUNCTION

### KEYLOCK function (SET pushbutton block)

The keyboard block function is activated at powering on, connecting the SYNC terminal to the positive power supply (+Vdc) for at least 1 s.

After the first second, the SYNC input is ready for the normal synchronisation operations (refer to next paragraph)

To deactivate the *keyboard block*, the sensor has to be turned off and re-powered maintaining the SYNC wire not connected or ground connected (GND).

### SYNC input (synchronisation)

The connection of the SYNC wire to +Vdc corresponds to the passive logic status while SYNC not connected or connected to 0 V corresponds to the active logic status.

SYNC passive = +Vdc ; SYNC active = 0V

The synchronisation signal allows to calculate the beginning and ending instants of the measurement. The reading cycle begins after the transition of the SYNC signal from passive to active and the sensor outputs are updated after max. 400µs.

All the outputs are deactivated after max. 400µs from the active – passive transition.

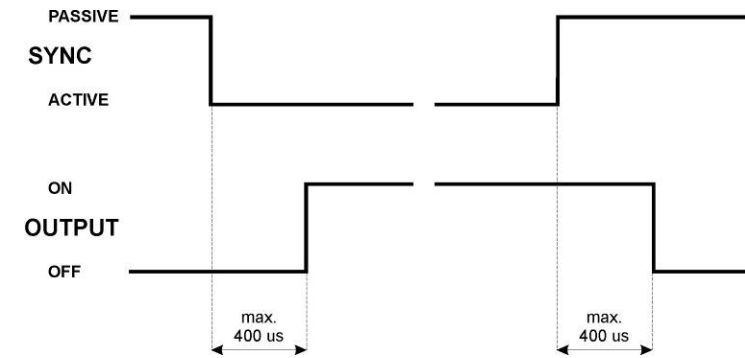

The SYNC wire is used also to determine the transmission direction when the RS485 serial connection is used.

### RS485 serial connection

The serial communication parameters are: 9600 baud, non-parity, 8 data bits, 1 stop bit. The refresh time of the serial port is 15ms.

The SYNC input is used to determine the communication direction, and in particular if low (active) direction S80->User, if high (passive) User->S80.

With SYNC active, the sensor continuously transmits the detected distance value (with a precision of 12bit) by means of a binary data format. 2 byte are used; one with bit 0 at logic level 1 identifies the more important byte.

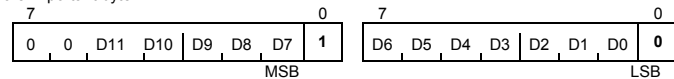

The RS485 serial interface allows also the complete remote control of the sensor. All the commands have to be sent via terminal in an ASCII format according to the following:

- **Receipt of the channel status:**  
At any moment, at the receipt of the 'r <CR> <LF>' remote command (and SYNC passive), the sensor configuration is restored.
- **Remote configuration:**  
The commands available are:  
  - @ <CR> <LF> beginning of the remote setting mode (and SYNC passive)
  - cx <CR> <LF> channel selection, with x ∈ {1, 2}
  - vxxx <CR> <LF> distance selection, with xxx ∈ {0...4095}
  - bx <CR> <LF> dark/light mode selection, with x ∈ {1, 2}  
    - b1 = Dark
    - b2 = Light
  - e <CR> <LF> memorisation of the configuration sequence.
  - q <CR> <LF> exit from remote setting without saving the configuration.
 At the receipt of the q <CR> <LF> or e <CR> <LF> commands, the sensor visualises ok <CR> <LF>.
- **Delay configuration:**  
The commands available are:  
  - @ <CR> <LF> beginning of the delay configuration (and SYNC passive)
  - dx <CR> <LF> delay selection, with x ∈ {0, 1, 2, 3, 4, 5}  
    - d0 = 0 ms      d3 = 20 ms
    - d1 = 5 ms      d4 = 30 ms
    - d2 = 10 ms     d5 = 40 ms
  - e <CR> <LF> memorisation of the new delay value
  - q <CR> <LF> exit from the delay configuration without saving the configuration.
 At the receipt of the q <CR> <LF> or e <CR> <LF> commands, the sensor visualises ok <CR> <LF>.
- **Normal/fast mode configuration:**  
The commands available are:  
  - @ <CR> <LF> beginning of the remote setting mode (and SYNC passive)
  - mx <CR> <LF> operating mode selection, with x ∈ {1, 2}  
    - m1 = normal mode
    - m2 = fast mode
  - e <CR> <LF> execution of configuration sequence.
  - q <CR> <LF> exit from the remote setting mode without saving the configuration.
 At the receipt of the q <CR> <LF> or e <CR> <LF> commands, the sensor visualises ok <CR> <LF>.

**NOTE:** the single digits have to be distanced amongst themselves at least 1 ms, during the command transmission.

## DETECTION DIAGRAMS

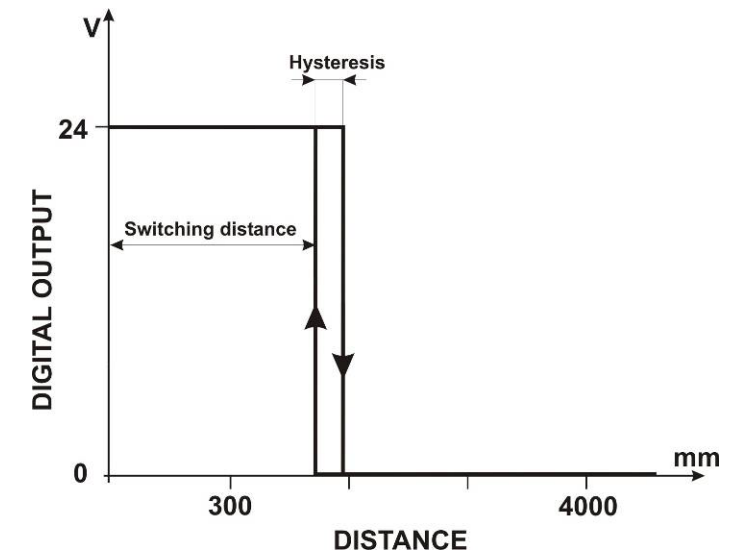
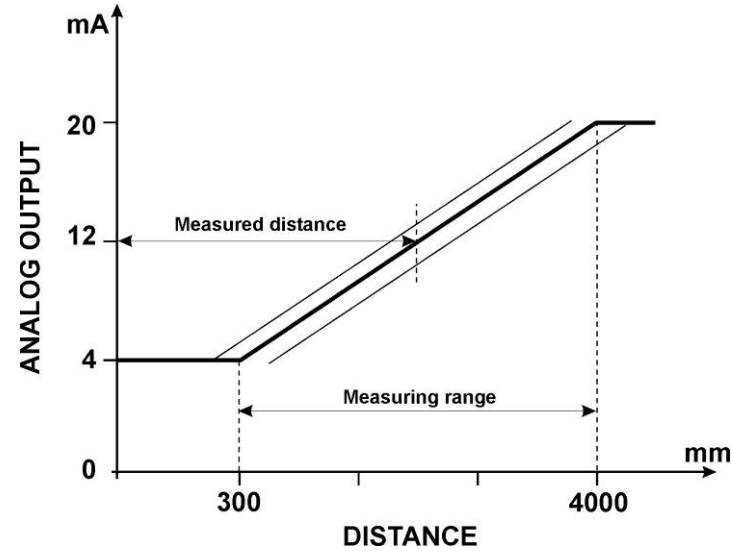

## SAFETY WARNINGS

All the safety electrical and mechanical regulations and laws have to be respected during sensor functioning. The sensor has to be protected against mechanical damages. Place the given labels in a visible position close to the laser emission.



Do not look directly into the laser beam!  
Do not point the laser beam towards people!  
Eye irradiation for over 0.25 seconds is dangerous; refer to class 2 standard (EN60825-1).  
These sensors are not conform to safety applications!

	<b>EX-II-3-D T6</b>	
	Temperature class:	T6 (<85°C)
	Max. Power consumption:	5100 mW at 30 Vdc
	Max. Internal capacitance:	187 nF
	Internal inductance:	negligible

**DECLARATION OF CONFORMITY**  
We DATASENSOR S.p.A. declare under our sole responsibility that these products are conform to the 2004/108/CE, 2006/95/CE Directives and successive amendments.

**WARRANTY**  
DATASENSOR S.p.A. warrants its products to be free from defects. DATASENSOR S.p.A. will repair or replace, free of charge, any product found to be defective during the warranty period of 36 months from the manufacturing date. This warranty does not cover damage or liability deriving from the improper application of DATASENSOR products.

DATASENSOR S.p.A. Via Lavino 265  
40050 Monte S. Pietro - Bologna - Italy  
Tel: +39 051 6765611 Fax: +39 051 6759324  
http://www.datasensor.com e-mail: info@datasensor.com

DATASENSOR S.p.A. cares for the environment: 100% recycled paper.  
DATASENSOR S.p.A. reserves the right to make modifications and improvements without prior notification.



## S80-MH-5-Y19

Distance sensor with laser emission and time of flight measurement

### INSTRUCTION MANUAL

CLASS 2 EN 60825-1 (1994)  
LASER PRODUCT

### CONTROLS

#### FRONT INDICATORS LED

##### OUTPUT LED

The yellow LED ON indicates the OR function of the OUT1 and OUT2 outputs (one of the 2 outputs is active).

##### ALARM LED

The red LED ON indicates the absence of signal.

#### COMMAND PANEL AND DISPLAY

##### OUTPUT LED

The yellow LED ON indicates the logic OR function of the two OUT1 and OUT2 outputs (one of the 2 outputs is active).

##### DISPLAY (4-digit green coloured display)

In the normal mode, the display indicates the detected distance, in millimetres. In presence of distances larger than 9999 millimetres, the display alternates the visualisation of the first important digit with the other 4 digits. The "LLLL" message on display means distance under the minimum value. The "HHHH" message on display means distance over the maximum value. The "FFFF" message on display means low signal received condition.

##### OUT1, OUT2 LEDs

The n.1 and n.2 green LEDs ON indicate the activation of the OUT1 and OUT2 outputs.

##### FAST LED

The n.3 green LED ON indicates the activation of the FAST reading mode (500 Hz).

##### SET PUSHBUTTON

A pressure on the pushbutton activates the self-setting procedure. A long pressure on the pushbutton allows the user to access into the mode (FAST or NORM) and delay setting menu.

##### +/- PUSHBUTTONS

A light pressure on these pushbuttons allows the user to run through the menu of the sensor parameters and setting menu. Moreover, a long pressure allows to change the switching threshold value, as indicated in the "SWITCHING THRESHOLD ADJUSTMENT" paragraph.

### INSTALLATION

The sensor can be positioned by means of the three housing's holes using screws (M5x40 or longer) with nuts and washers.

Various orientable fixing brackets to ease the sensor positioning are available (please refer to the accessories listed in the catalogue). For correct functioning, the sensor requires the RT3870 reflector available on rigid support.

Adjust the sensor position to guarantee that the spot is inside the reflector's surface (Fig.1).

The operating distance is measured from the front surface of the sensor optics up to the reflector surface. The M12 connector can be oriented at two different positions (Fig.2).

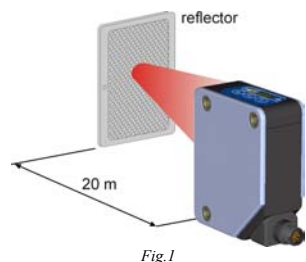

Fig.1



Fig.2

### CONNECTIONS

#### M12 CONNECTOR

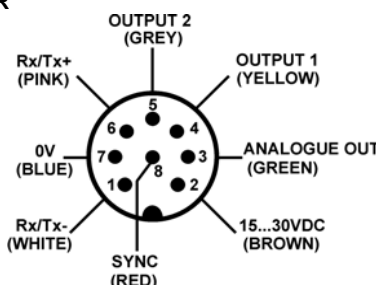

NOTE: the wire colours are referred to the cables manufactured according to the European standard.

### TECHNICAL DATA

Power supply:	15 ... 30 Vdc limit values
Ripple:	2 Vpp max.
Consumption (output current excluded):	130 mA max (110 mA @ 24V)
Outputs:	2 PNP or NPN outputs 30 Vdc max. (short-circuit protection) analogue output with 4-20 mA
Serial interface:	RS485, 9600Bd, 8N1
SYNC input:	PNP
Measurement range:	300 ... 20300 mm
Linearity:	0.25% (24 Vdc, 25 °C, using the RT3870 reflector)
Repeatability:	≤ 10 mm (NORM)
Digital resolution:	0.61 mm
Hysteresis:	25 mm (NORM); 35 mm (FAST)
Temperature drift:	< 2 mm/°C
Output current:	100 mA max.
Output saturation voltage:	≤ 2 V
Response time:	5 ms (NORM); 1 ms (FAST)
Switching frequency:	100 HZ (NORM); 500 HZ (FAST)
Indicators:	<b>command panel:</b> 4-digit display (GREEN), OUTPUT LED (YELLOW) 2 OUT1, OUT2 LEDs (GREEN) FAST LED (GREEN).
(refer to "Controls" paragraph):	<b>Indicators LED:</b> OUTPUT LED (YELLOW) / ALARM LED (RED)
Setting:	SET, +, - pushbuttons
Data retention:	non volatile EEPROM memory
Operating temperature:	-10 ... 50 °C
Storage temperature:	-20 ... 70 °C
Insulating strength:	500 Vac 1 min., between electronics and housing
Insulating resistance:	20 MΩ 500 Vdc, between electronics and housing
Minimum and maximum spot dimension:	∅ 21 mm - 32 mm at 4 m ∅ 75 mm - 140 mm at 20 m
Emission type:	Red laser (665 nm) Class 2 (λ. 665 nm) EN 60825-1 (1994)
Ambient light rejection:	According to EN 60947-5-2
Vibrations:	0.5 mm amplitude, 10 ... 55 Hz frequency, for every axis (EN60068-2-6)
Shock resistance:	11 ms (30 G) 6 shock for every axis (EN60068-2-27)
Housing material:	aluminium
Lens material:	Window and lenses in glass
Mechanical protection:	IP67
Connections:	M12-8 pole connector
Weight:	330 g. max.

### DIMENSIONS

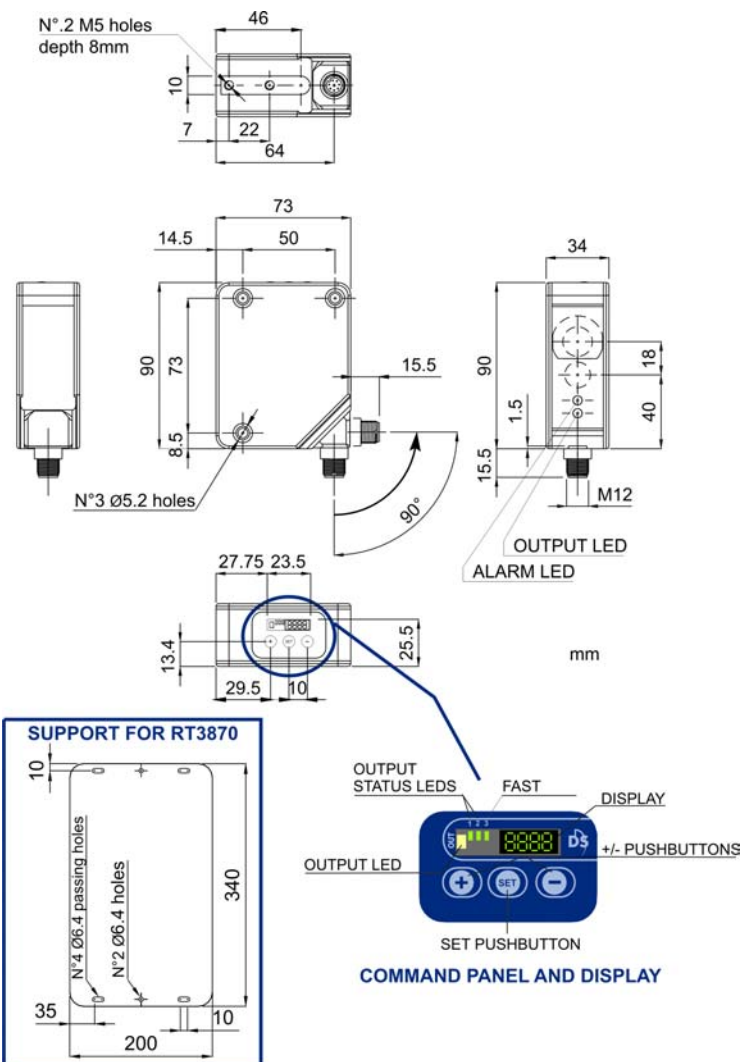

### SETTING OF THE 2 CHANNELS

**Legend:** ● pushbutton pressed ○ pushbutton not pressed  
■ LED on □ LED off

The switching threshold setting for each of the 2 channels and the selection of the logic switching is effected placing directly the object to detect in front of the sensor, according to the following procedure:

#### - Detection

- Place the object to detect in front of the sensor.

	OUT			Display				Keyboard		
OR	1	2	3	Dig1	Dig2	Dig3	Dig4	+	SET	-
■	□	■	□	1	9	4	5	○	●	○

- Press the SET pushbutton for at least 2 s.

- The "CH-1" message appears.

OR	1	2	3	Dig1	Dig2	Dig3	Dig4	+	SET	-
□	□	□	□	C	H	-	1	○	●	○

#### - Channel selection

- To select the channel setting use the +/- pushbuttons.

OR	1	2	3	Dig1	Dig2	Dig3	Dig4	+	SET	-
□	□	□	□	C	H	-	1	●	○	●

□	□	□	□	C	H	-	2	●	○	●
---	---	---	---	---	---	---	---	---	---	---

#### - DARK/LIGHT selection

- Press the SET pushbutton again for at least 0.5 s.

- The "L On" message appears.

OR	1	2	3	Dig1	Dig2	Dig3	Dig4	+	SET	-
□	□	□	□	L	O	n	○	●	○	○

- To select the DARK/LIGHT mode of the channel use the +/- pushbuttons.

- "L on" is visualised when the LIGHT mode is selected; "d On" in case of DARK mode

OR	1	2	3	Dig1	Dig2	Dig3	Dig4	+	SET	-
□	□	□	□	L	O	n	○	●	○	○

□	□	□	□	d	O	n	○	●	○	○
---	---	---	---	---	---	---	---	---	---	---

#### - Target detection phase

- Press the SET pushbutton for at least 0.5 s, the "uPd;" message begins to blink (4Hz, for 2 s).

OR	1	2	3	Dig1	Dig2	Dig3	Dig4	+	SET	-
□	□	□	□	u	P	d	;	○	●	○

- The detection distance value appears.

- The +/- pushbuttons can be used to change the detected distance value.

OR	1	2	3	Dig1	Dig2	Dig3	Dig4	+	SET	-
■	□	■	□	1	9	4	5	○	●	○

- The units change if these pushbuttons are pressed repeatedly, the tens if kept pressed.

- Press the SET pushbutton again for at least 0.5 s. to end the detection phase.

OR	1	2	3	Dig1	Dig2	Dig3	Dig4	+	SET	-
■	□	■	□	1	9	4	5	○	●	○

### SWITCHING THRESHOLD ADJUSTMENT

	OUT			Display				Keyboard		
OR	1	2	3	Dig1	Dig2	Dig3	Dig4	+	SET	-
■	□	■	□	1	9	4	5	○	●	○

- Press the +/- pushbuttons for at least 2 s.

- The "CH-1" message appears.

OR	1	2	3	Dig1	Dig2	Dig3	Dig4	+	SET	-
■	□	■	□	C	H	-	1	○	○	○

#### - Channel selection

- Use the +/- pushbuttons to select the channel to detect.

OR	1	2	3	Dig1	Dig2	Dig3	Dig4	+	SET	-
■	□	■	□	C	H	-	1	○	○	○

■	□	■	□	C	H	-	2	○	○	○
---	---	---	---	---	---	---	---	---	---	---

#### - Distance of threshold phase

- Press the SET pushbutton for at least 0.5 s.

- The previously detected distance value appears.

- Use the +/- pushbuttons to change the detected distance value.

- The units change if these pushbuttons are pressed repeatedly, the tens if kept pressed.

OR	1	2	3	Dig1	Dig2	Dig3	Dig4	+	SET	-
■	□	■	□	1	9	4	5	○	●	○

- Press the SET pushbutton again for at least 0.5 s. to end the adjustment phase.

OR	1	2	3	Dig1	Dig2	Dig3	Dig4	+	SET	-
■	□	■	□	1	9	6	0	○	●	○

### SETTING OF THE PARAMETERS

	OUT			Display				Keyboard		
OR	1	2	3	Dig1	Dig2	Dig3	Dig4	+	SET	-
□	□	□	□	1	9	4	5	○	●	○

Press the SET pushbutton for at least 6 s to enter into the parameter setting menu.

The "MEnu" message appears.

OR	1	2	3	Dig1	Dig2	Dig3	Dig4	+	SET	-
□	□	□	□	M	E	n	u	○	○	○

Pressing the + and - pushbuttons the user can run up and down the menu, reading the following messages.

#### - Functioning mode selection

- At each pressure of the SET pushbutton, the user can run through the options of the selected level.

OR	1	2	3	Dig1	Dig2	Dig3	Dig4	+	SET	-
□	□	□	□	n	O	r	M	○	○	○

□	□	□	□	F	A	S	t	○	●	○
---	---	---	---	---	---	---	---	---	---	---

- The setting of the normal of fast mode is in common to both outputs.

#### - Delay setting

- At each pressure of the SET pushbutton, the user can run through the options of the selected level.

OR	1	2	3	Dig1	Dig2	Dig3	Dig4	+	SET	-
□	□	□	□	d	-	0	0	○	○	○

□	□	□	□	d	-	1	0	○	○	○
---	---	---	---	---	---	---	---	---	---	---

□	□	□	□	d	-	2	0	○	○	○
---	---	---	---	---	---	---	---	---	---	---

□	□	□	□	d	-	3	0	○	○	○
---	---	---	---	---	---	---	---	---	---	---

□	□	□	□	d	-	4	0	○	○	○
---	---	---	---	---	---	---	---	---	---	---

- The delay value setting is in common to both outputs.

- When a delay value, different from zero, is set, the outputs will be maintained active for a minimum time equal to the number of milliseconds visualised on the display.

#### - Visualisation of the channel 1 data

- At each pressure of the SET pushbutton, the user can run through the options of the selected level.

OR	1	2	3	Dig1	Dig2	Dig3	Dig4	+	SET	-
□	□	□	□	C	H	-	1	○	○	○

THRESHOLD	1	9	4	5	○	○	○	○	○	○
-----------	---	---	---	---	---	---	---	---	---	---

MODE	L/d	-	O	n	○	○	○	○	○	○
------	-----	---	---	---	---	---	---	---	---	---

#### - Visualisation of the channel 2 data

At each pressure of the SET pushbutton, the user can run through the options of the selected level.

OR	1	2	3	Dig1	Dig2	Dig3	Dig4	+	SET	-
□	□	□	□	C	H	-	2	○	○	○

THRESHOLD	1	9	4	5	○	○	○	○	○	○
-----------	---	---	---	---	---	---	---	---	---	---

MODE	L/d	-	O	n	○	○	○	○	○	○
------	-----	---	---	---	---	---	---	---	---	---

#### - Serial output deactivation

At each pressure of the SET pushbutton, the user can run through the options of the selected level.

OR	1	2	3	Dig1	Dig2	Dig3	Dig4	+	SET	-
□	□	□	□	S	-	o	n	○	○	○

□	□	□	□	S	-	o	f	○	○	○
---	---	---	---	---	---	---	---	---	---	---

#### - Memorisation of the parameters set

OR	1	2	3	Dig1	Dig2	Dig3	Dig4	+	SET	-
□	□	□	□	S	A	V	E	○	○	○

□	□	□	□	S	A	V	E	○	○
---	---	---	---	---	---	---	---	---	---

## REMOTE FUNCTION

### KEYLOCK function (SET pushbutton block)

The keyboard block function is activated at powering on, connecting the SYNC terminal to the positive power supply (+Vdc) for at least 1 s.

After the first second, the SYNC input is ready for the normal synchronisation operations (refer to next paragraph)

To deactivate the *keyboard block*, the sensor has to be turned off and re-powered maintaining the SYNC wire not connected or ground connected (GND).

### SYNC input (synchronisation)

The connection of the SYNC wire to +Vdc corresponds to the passive logic status while SYNC not connected or connected to 0 V corresponds to the active logic status.

SYNC passive = +Vdc ; SYNC active = 0V

The synchronisation signal allows to calculate the beginning and ending instants of the measurement. The reading cycle begins after the transition of the SYNC signal from passive to active and the sensor outputs are updated after max. 400µs.

All the outputs are deactivated after max. 400µs from the active – passive transition.

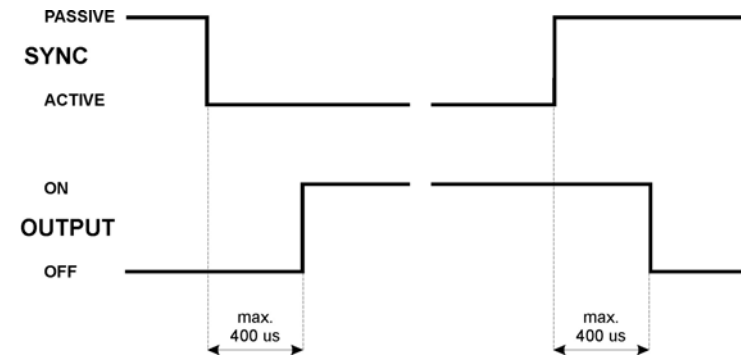

The SYNC wire is used also to determine the transmission direction when the RS485 serial connection is used.

### RS485 serial connection

The serial communication parameters are: 9600 baud, non-parity, 8 data bits, 1 stop bit.

The refresh time of the serial port is 15ms.

The SYNC input is used to determine the communication direction, and in particular if low (active) direction S80->User, if high (passive) User->S80.

With SYNC active, the sensor continuously transmits the detected distance value (with a precision of 15bit) in a binary data format. 3 bytes are used: one byte with bit 0 at logic level 0 identifying the less important byte, a second byte with bit 6 at logic level 1 and bit 7 at logic level 0 identifying the intermediate byte, and finally a third byte with bits 6 and 7 at logic level 1 identifying the most important byte.

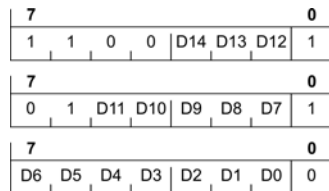

The RS485 serial interface allows also the complete remote control of the sensor.

All the commands have to be sent via terminal in an ASCII format according to the following:

- **Receipt of the channel status:**  
At any moment, at the receipt of the 'r <CR> <LF>' remote command (and SYNC passive), the sensor configuration is restored.
- **Remote configuration:**  
The commands available are:  
 @ <CR> <LF> beginning of the remote setting mode (and SYNC passive)  
 cx <CR> <LF> channel selection, with x ∈ {1, 2}  
 vxxx <CR> <LF> distance selection, with xxx ∈ {0...4095}  
 bx <CR> <LF> dark/light mode selection, with x ∈ {1, 2}  
     b1 = Dark  
     b2 = Light  
 e <CR> <LF> memorisation of the configuration sequence.  
 q <CR> <LF> exit from remote setting without saving the configuration.  
 At the receipt of the q <CR> <LF> or e <CR> <LF> commands, the sensor visualises ok <CR> <LF>.
- **Delay configuration:**  
The commands available are:  
 @ <CR> <LF> beginning of the delay configuration (and SYNC passive)  
 dx <CR> <LF> delay selection, with x ∈ {0, 1, 2, 3, 4, 5}  
     d0 = 0 ms      d3 = 20 ms  
     d1 = 5 ms      d4 = 30 ms  
     d2 = 10 ms     d5 = 40 ms  
 e <CR> <LF> memorisation of the new delay value  
 q <CR> <LF> exit from the delay configuration without saving the configuration.  
 At the receipt of the q <CR> <LF> or e <CR> <LF> commands, the sensor visualises ok <CR> <LF>.
- **Normal/fast mode configuration:**  
The commands available are:  
 @ <CR> <LF> beginning of the remote setting mode (and SYNC passive)  
 mx <CR> <LF> operating mode selection, with x ∈ {1, 2}  
     m1 = normal mode  
     m2 = fast mode  
 e <CR> <LF> execution of configuration sequence.  
 q <CR> <LF> exit from the remote setting mode without saving the configuration.  
 At the receipt of the q <CR> <LF> or e <CR> <LF> commands, the sensor visualises ok <CR> <LF>.

**NOTE: the single digits have to be distanced amongst themselves at least 1 ms, during the command transmission.**

## DETECTION DIAGRAMS

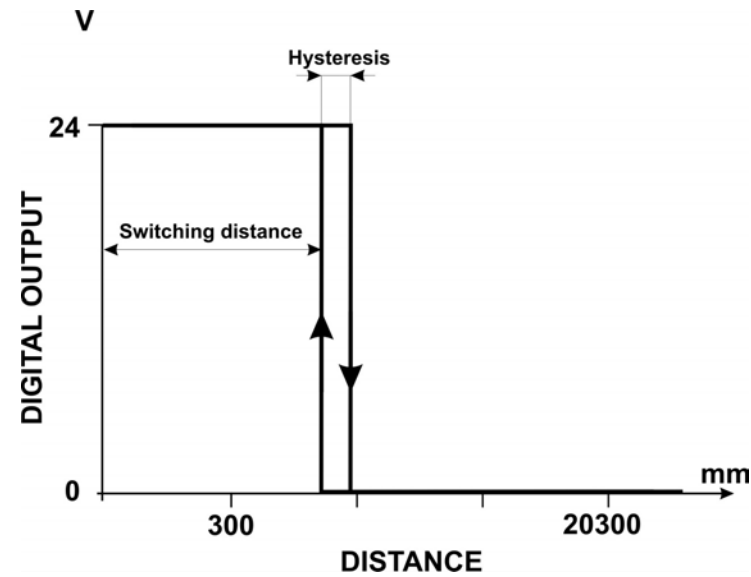
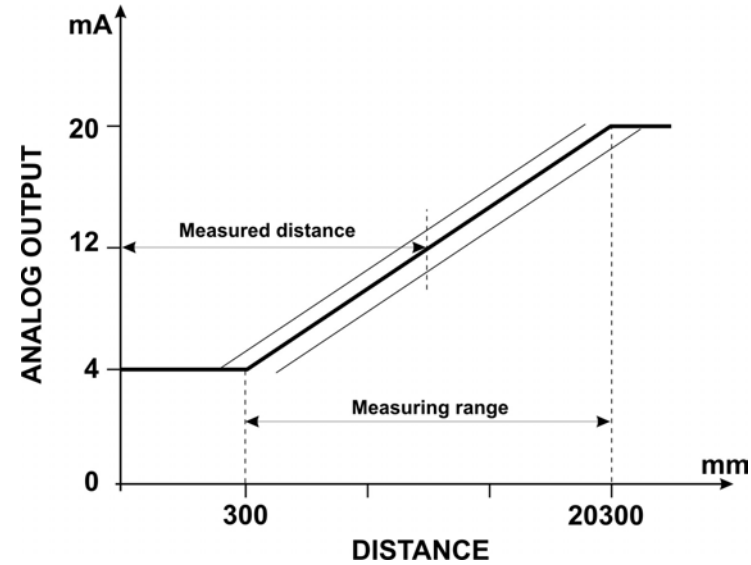

## SAFETY WARNINGS

All the safety electrical and mechanical regulations and laws have to be respected during sensor functioning. The sensor has to be protected against mechanical damages. Place the given labels in a visible position close to the laser emission.



Do not look directly into the laser beam!  
Do not point the laser beam towards people!  
Eye irradiation for over 0.25 seconds is dangerous; refer to class 2 standard (EN60825-1).  
These sensors are not conform to safety applications!

	<b>EX-II-3-D T6</b>	
	Temperature class:	T6 (<85°C)
	Max. Power consumption:	5100 mW at 30 Vdc
	Max. Internal capacitance:	187 nF
	Internal inductance:	negligible

### DECLARATION OF CONFORMITY

We DATASENSOR S.p.A. declare under our sole responsibility that these products are conform to the 2004/108/CE, 2006/95/CE Directives and successive amendments.

### WARRANTY

DATASENSOR S.p.A. warrants its products to be free from defects. DATASENSOR S.p.A. will repair or replace, free of charge, any product found to be defective during the warranty period of 36 months from the manufacturing date. This warranty does not cover damage or liability deriving from the improper application of DATASENSOR products.

DATASENSOR S.p.A. Via Lavino 265  
40050 Monte S. Pietro - Bologna - Italy  
Tel: +39 051 6765611 Fax: +39 051 6759324  
http://www.datasensor.com e-mail: info@datasensor.com

DATASENSOR S.p.A. cares for the environment: 100% recycled paper.  
 DATASENSOR S.p.A. reserves the right to make modifications and improvements without prior notification.





## S80-MH-5-Y29

Distance sensor with laser emission and time of flight measurement

### INSTRUCTION MANUAL

CLASS 2 EN 60825-1 (1994)  
LASER PRODUCT

### CONTROLS

#### FRONT INDICATORS LED

##### OUTPUT LED

The yellow LED ON indicates the OR function of the OUT1 and OUT2 outputs (one of the 2 outputs is active).

##### ALARM LED

The red LED ON indicates the absence of signal.

#### COMMAND PANEL AND DISPLAY

##### OUTPUT LED

The yellow LED ON indicates the logic OR function of the two OUT1 and OUT2 outputs (one of the 2 outputs is active).

##### DISPLAY (4-digit green coloured display)

In the normal mode, the display indicates the detected distance, in centimetres. In presence of distances larger than 9999 millimetres, the display alternates the visualisation of the first important digit with the other 4 digits. The "LLLL" message on display means distance under the minimum value. The "HHHH" message on display means distance over the maximum value. The "FFFF" message on display means low signal received condition.

##### OUT1, OUT2 LEDs

The n.1 and n.2 green LEDs ON indicate the activation of the OUT1 and OUT2 outputs.

##### FAST LED

The n.3 green LED ON indicates the activation of the FAST reading mode (500 Hz).

##### SET PUSHBUTTON

A pressure on the pushbutton activates the self-setting procedure. A long pressure on the pushbutton allows the user to access into the mode (FAST or NORM) and delay setting menu.

##### +/- PUSHBUTTONS

A light pressure on these pushbuttons allows the user to run through the menu of the sensor parameters and setting menu. Moreover, a long pressure allows to change the switching threshold value, as indicated in the "SWITCHING THRESHOLD ADJUSTMENT" paragraph.

### INSTALLATION

The sensor can be positioned by means of the three housing's holes using screws (M5x40 or longer) with nuts and washers.

Various orientable fixing brackets to ease the sensor positioning are available (please refer to the accessories listed in the catalogue).

For correct functioning, the sensor requires the RT3870 reflector. A second reflector, aligned next to the first, is recommended for distances larger than 70 m, as shown in Fig.1. The reflector is available on rigid support. Adjust the sensor position to guarantee that the spot is inside the reflector's surface (Fig.1). The operating distance is measured from the front surface of the sensor optics up to the reflector surface. The M12 connector can be oriented at two different positions (Fig.2).

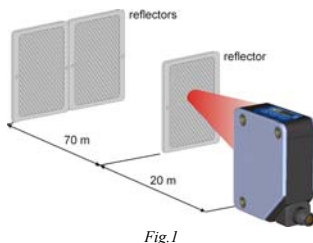
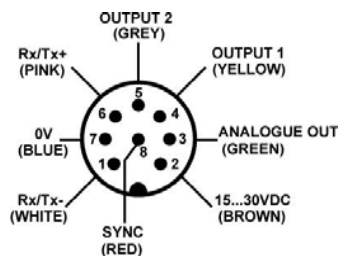

Fig. 2

### CONNECTIONS

#### M12 CONNECTOR



NOTE: the wire colours are referred to the cables manufactured according to the European standard.

### TECHNICAL DATA

Power supply:	15 ... 30 Vdc limit values
Ripple:	2 Vpp max.
Consumption (output current excluded):	130 mA max (110 mA @ 24V)
Outputs:	2 PNP or NPN outputs 30 Vdc max. (short-circuit protection) analogue output with 4-20 mA
Serial interface:	RS485, 9600Bd, 8N1
SYNC input:	PNP
Measurement range:	30 ... 10030 cm
Linearity:	0.15% (24 Vdc, 25 °C, using the RT3870 reflector)
Repeatability:	≤ 10 mm (NORM)
Digital resolution:	0.61 cm
Hysteresis:	40 mm (NORM); 60 mm (FAST)
Temperature drift:	< 2 mm/°C
Output current:	100 mA max.
Output saturation voltage:	≤ 2 V
Response time:	5 ms (NORM); 1 ms (FAST)
Switching frequency:	100 HZ (NORM); 500 HZ (FAST)
Indicators (refer to "Controls" paragraph):	<b>command panel:</b> 4-digit display (GREEN), OUTPUT LED (YELLOW) 2 OUT1, OUT2 LEDs (GREEN) FAST LED (GREEN). <b>Indicators LED:</b> OUTPUT LED (YELLOW) / ALARM LED (RED)
Setting:	SET, +/- pushbuttons
Data retention:	non volatile EEPROM memory
Operating temperature:	-10 ... 50 °C
Storage temperature:	-20 ... 70 °C
Insulating strength:	500 Vac 1 min., between electronics and housing
Insulating resistance:	20 MΩ 500 Vdc, between electronics and housing
Minimum and maximum spot dimension:	∅ 21 mm - 32 mm at 4 m ∅ 404 mm - 662 mm at 100 m
Typical spot dimension:	∅ 12 mm at 2 m ∅ 20 mm at 4 m
Emission type:	Red laser (665 nm) Class 2 (λ 665 nm) EN 60825-1 (1994)
Ambient light rejection:	According to EN 60947-5-2
Vibrations:	0.5 mm amplitude, 10 ... 55 Hz frequency, for every axis (EN60068-2-6)
Shock resistance:	11 ms (30 G) 6 shock for every axis (EN60068-2-27)
Housing material:	aluminium
Lens material:	Window and lenses in glass
Mechanical protection:	IP67
Connections:	M12-8 pole connector
Weight:	330 g. max.

### DIMENSIONS

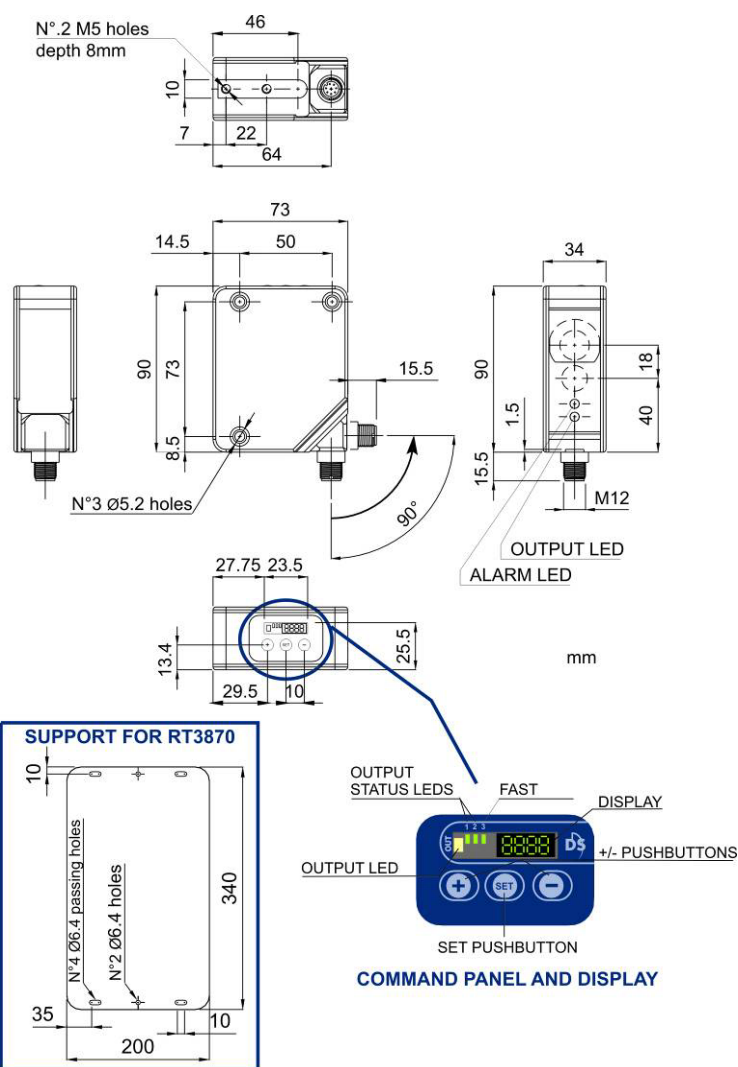

### SETTING OF THE 2 CHANNELS

**Legend:** ● pushbutton pressed ○ pushbutton not pressed  
■ LED on □ LED off

The switching threshold setting for each of the 2 channels and the selection of the logic switching is effected placing directly the object to detect in front of the sensor, according to the following procedure:

#### - Detection

- Place the object to detect in front of the sensor.

	OUT			Display				Keyboard		
OR	1	2	3	Dig1	Dig2	Dig3	Dig4	+	SET	-
■	□	■	□	1	9	4	5	○	●	○

- Press the SET pushbutton for at least 2 s.

- The "CH-1" message appears.

OR	1	2	3	Dig1	Dig2	Dig3	Dig4	+	SET	-
□	□	□	□	C	H	-	1	○	●	○

#### - Channel selection

- To select the channel setting use the +/- pushbuttons.

OR	1	2	3	Dig1	Dig2	Dig3	Dig4	+	SET	-
□	□	□	□	C	H	-	1	●	○	●
□	□	□	□	C	H	-	2	●	○	●

#### - DARK/LIGHT selection

- Press the SET pushbutton again for at least 0.5 s.

- The "L On" message appears.

OR	1	2	3	Dig1	Dig2	Dig3	Dig4	+	SET	-
□	□	□	□	L	O	n	○	●	○	○

- To select the DARK/LIGHT mode of the channel use the +/- pushbuttons.

- "L on" is visualised when the LIGHT mode is selected; "d On" in case of DARK mode

OR	1	2	3	Dig1	Dig2	Dig3	Dig4	+	SET	-
□	□	□	□	L	O	n	○	●	○	●
□	□	□	□	d	O	n	○	●	○	●

#### - Target detection phase

- Press the SET pushbutton for at least 0.5 s, the "uPdt" message begins to blink (4Hz, for 2 s).

OR	1	2	3	Dig1	Dig2	Dig3	Dig4	+	SET	-
□	□	□	□	u	P	d	t	○	●	○

- The detection distance value appears.

- The +/- pushbuttons can be used to change the detected distance value.

OR	1	2	3	Dig1	Dig2	Dig3	Dig4	+	SET	-
■	□	■	□	1	9	4	5	●	○	●

- The units change if these pushbuttons are pressed repeatedly, the tens if kept pressed.

- Press the SET pushbutton again for at least 0.5 s. to end the detection phase.

OR	1	2	3	Dig1	Dig2	Dig3	Dig4	+	SET	-
■	□	■	□	1	9	4	5	○	●	○

### SWITCHING THRESHOLD ADJUSTMENT

	OUT			Display				Keyboard		
OR	1	2	3	Dig1	Dig2	Dig3	Dig4	+	SET	-
■	□	■	□	1	9	4	5	●	○	●

- Press the +/- pushbuttons for at least 2 s.

- The "CH-1" message appears.

OR	1	2	3	Dig1	Dig2	Dig3	Dig4	+	SET	-
■	□	■	□	C	H	-	1	○	○	○

#### - Channel selection

- Use the +/- pushbuttons to select the channel to detect.

OR	1	2	3	Dig1	Dig2	Dig3	Dig4	+	SET	-
■	□	■	□	C	H	-	1	○	○	○
■	□	■	□	C	H	-	2	●	○	●

#### - Distance of threshold phase

- Press the SET pushbutton for at least 0.5 s.

- The previously detected distance value appears.

- Use the +/- pushbuttons to change the detected distance value.

- The units change if these pushbuttons are pressed repeatedly, the tens if kept pressed.

OR	1	2	3	Dig1	Dig2	Dig3	Dig4	+	SET	-
■	□	■	□	1	9	4	5	●	○	●

- Press the SET pushbutton again for at least 0.5 s. to end the adjustment phase.

OR	1	2	3	Dig1	Dig2	Dig3	Dig4	+	SET	-
■	□	■	□	1	9	6	0	○	●	○

### SETTING OF THE PARAMETERS

	OUT			Display				Keyboard		
OR	1	2	3	Dig1	Dig2	Dig3	Dig4	+	SET	-
□	□	□	□	1	9	4	5	○	●	○

Press the SET pushbutton for at least 6 s to enter into the parameter setting menu.

The "MEnu" message appears.

OR	1	2	3	Dig1	Dig2	Dig3	Dig4	+	SET	-
□	□	□	□	M	E	n	u	○	○	○

Pressing the + and - pushbuttons the user can run up and down the menu, reading the following messages.

#### - Functioning mode selection

- At each pressure of the SET pushbutton, the user can run through the options of the selected level.

OR	1	2	3	Dig1	Dig2	Dig3	Dig4	+	SET	-
□	□	□	□	n	O	r	M	○	○	○

F	A	S	t	○	●	○
---	---	---	---	---	---	---

- The setting of the normal of fast mode is in common to both outputs.

#### - Delay setting

- At each pressure of the SET pushbutton, the user can run through the options of the selected level.

OR	1	2	3	Dig1	Dig2	Dig3	Dig4	+	SET	-
□	□	□	□	d	-	0	0	○	○	○

d	-	0	5	○	●	○
---	---	---	---	---	---	---

d	-	1	0	○	●	○
---	---	---	---	---	---	---

d	-	2	0	○	●	○
---	---	---	---	---	---	---

d	-	3	0	○	●	○
---	---	---	---	---	---	---

d	-	4	0	○	●	○
---	---	---	---	---	---	---

- The delay value setting is in common to both outputs.

- When a delay value, different from zero, is set, the outputs will be maintained active for a minimum time equal to the number of milliseconds visualised on the display.

#### - Visualisation of the channel 1 data

- At each pressure of the SET pushbutton, the user can run through the options of the selected level.

OR	1	2	3	Dig1	Dig2	Dig3	Dig4	+	SET	-
□	□	□	□	C	H	-	1	○	○	○

THRESHOLD	1	9	4	5	○	●	○
-----------	---	---	---	---	---	---	---

MODE	L/d	-	O	n	○	●	○
------	-----	---	---	---	---	---	---

#### - Visualisation of the channel 2 data

At each pressure of the SET pushbutton, the user can run through the options of the selected level.

OR	1	2	3	Dig1	Dig2	Dig3	Dig4	+	SET	-
□	□	□	□	C	H	-	2	○	○	○

THRESHOLD	1	9	4	5	○	●	○
-----------	---	---	---	---	---	---	---

MODE	L/d	-	O	n	○	●	○
------	-----	---	---	---	---	---	---

#### - Serial output deactivation

At each pressure of the SET pushbutton, the user can run through the options of the selected level.

OR	1	2	3	Dig1	Dig2	Dig3	Dig4	+	SET	-
□	□	□	□	S	-	o	n	○	○	○

S	-	o	f	○	●	○
---	---	---	---	---	---	---

#### - Memorisation of the parameters set

OR	1	2	3	Dig1	Dig2	Dig3	Dig4	+	SET	-
□	□	□	□	S	A	V	E	○	○	○

S	A	V	E	○	●	○
---	---	---	---	---	---	---

- Pressing the SET pushbutton (the SAVE message blinks for 2s, 4Hz) all the changed values are saved and the user exits from the menu, and returns to the normal mode.  
- One of the +/- pushbuttons has to be pressed to return to the setting menu.

#### - Exit from the parameter setting menu

After a 10 s inactivity of the pushbuttons, the sensor returns to the normal mode visualising the distance.

## REMOTE FUNCTION

### KEYLOCK function (SET pushbutton block)

The keyboard block function is activated at powering on, connecting the SYNC terminal to the positive power supply (+Vdc) for at least 1 s.

After the first second, the SYNC input is ready for the normal synchronisation operations (refer to next paragraph)

To deactivate the *keyboard block*, the sensor has to be turned off and re-powered maintaining the SYNC wire not connected or ground connected (GND).

### SYNC input (synchronisation)

The connection of the SYNC wire to +Vdc corresponds to the passive logic status while SYNC not connected or connected to 0 V corresponds to the active logic status.

SYNC passive = +Vdc ; SYNC active = 0V

The synchronisation signal allows to calculate the beginning and ending instants of the measurement. The reading cycle begins after the transition of the SYNC signal from passive to active and the sensor outputs are updated after max. 400µs.

All the outputs are deactivated after max. 400µs from the active – passive transition.

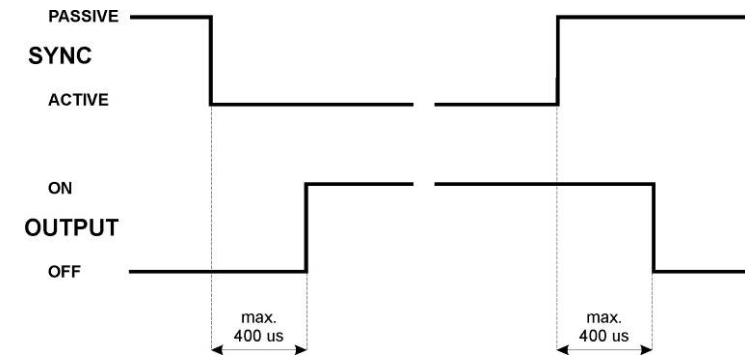

The SYNC wire is used also to determine the transmission direction when the RS485 serial connection is used.

### RS485 serial connection

The serial communication parameters are: 9600 baud, non-parity, 8 data bits, 1 stop bit. The refresh time of the serial port is 15ms.

The SYNC input is used to determine the communication direction, and in particular if low (active) direction S80->User, if high (passive) User->S80.

With SYNC active, the sensor continuously transmits the detected distance value (with a precision of 14bit) in a binary data format. 3 bytes are used: one byte with bit 0 at logic level 0 identifying the less important byte, a second byte with bit 6 at logic level 1 and bit 7 at logic level 0 identifying the intermediate byte, and finally a third byte with bits 6 and 7 at logic level 1 identifying the most important byte.

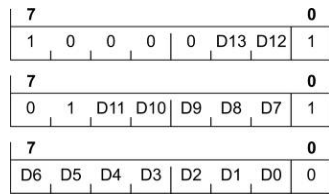

The RS485 serial interface allows also the complete remote control of the sensor. All the commands have to be sent via terminal in an ASCII format according to the following:

- **Receipt of the channel status:**  
At any moment, at the receipt of the 'r <CR> <LF>' remote command (and SYNC passive), the sensor configuration is restored.
- **Remote configuration:**  
The commands available are:  
 @ <CR> <LF> beginning of the remote setting mode (and SYNC passive)  
 cx <CR> <LF> channel selection, with x ∈ {1, 2}  
 vxxx <CR> <LF> distance selection, with xxx ∈ {0...4095}  
 bx <CR> <LF> dark/light mode selection, with x ∈ {1, 2}  
     b1 = Dark  
     b2 = Light  
 e <CR> <LF> memorisation of the configuration sequence.  
 q <CR> <LF> exit from remote setting without saving the configuration.  
 At the receipt of the q <CR> <LF> or e <CR> <LF> commands, the sensor visualises ok <CR> <LF>.
- **Delay configuration:**  
The commands available are:  
 @ <CR> <LF> beginning of the delay configuration (and SYNC passive)  
 dx <CR> <LF> delay selection, with x ∈ {0, 1, 2, 3, 4, 5}  
     d0 = 0 ms      d3 = 20 ms  
     d1 = 5 ms      d4 = 30 ms  
     d2 = 10 ms     d5 = 40 ms  
 e <CR> <LF> memorisation of the new delay value  
 q <CR> <LF> exit from the delay configuration without saving the configuration.  
 At the receipt of the q <CR> <LF> or e <CR> <LF> commands, the sensor visualises ok <CR> <LF>.
- **Normal/fast mode configuration:**  
The commands available are:  
 @ <CR> <LF> beginning of the remote setting mode (and SYNC passive)  
 mx <CR> <LF> operating mode selection, with x ∈ {1, 2}  
     m1 = normal mode  
     m2 = fast mode  
 e <CR> <LF> execution of configuration sequence.  
 q <CR> <LF> exit from the remote setting mode without saving the configuration.  
 At the receipt of the q <CR> <LF> or e <CR> <LF> commands, the sensor visualises ok <CR> <LF>.

**NOTE:** the single digits have to be distanced amongst themselves at least 1 ms, during the command transmission.

## DETECTION DIAGRAMS

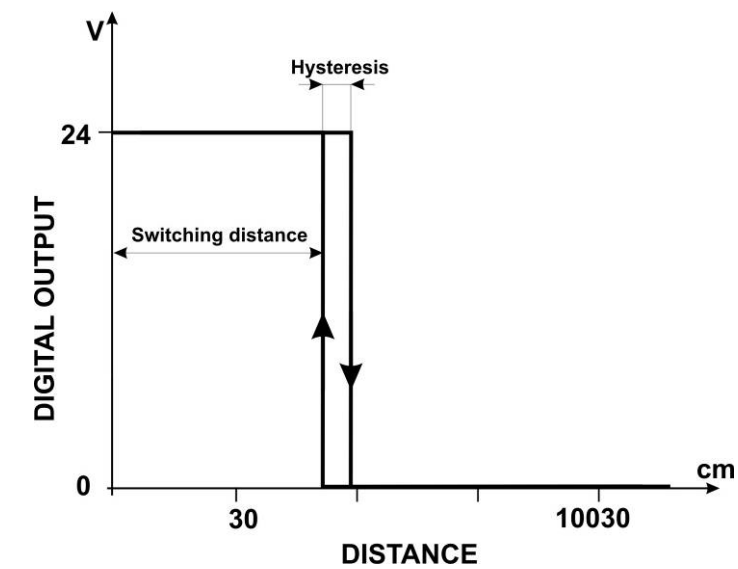
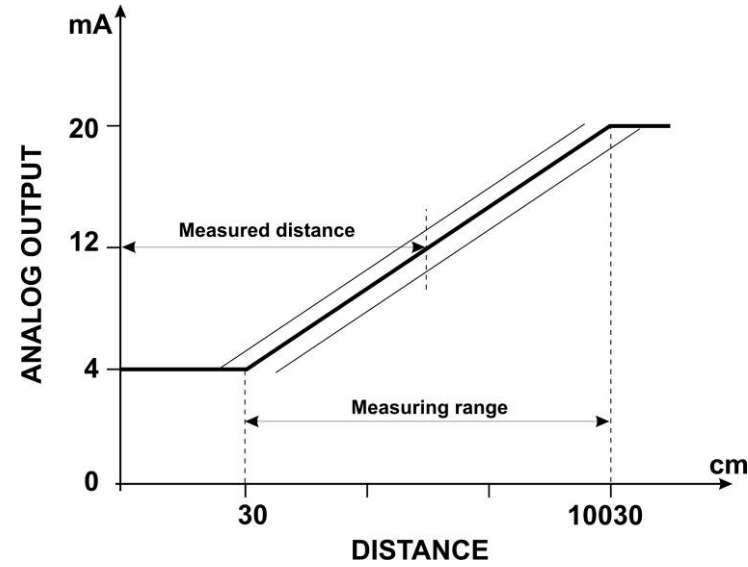

## SAFETY WARNINGS

All the safety electrical and mechanical regulations and laws have to be respected during sensor functioning. The sensor has to be protected against mechanical damages. Place the given labels in a visible position close to the laser emission.



Do not look directly into the laser beam!  
Do not point the laser beam towards people!  
Eye irradiation for over 0.25 seconds is dangerous; refer to class 2 standard (EN60825-1).  
These sensors are not conform to safety applications!

	<b>EX-II-3-D T6</b>	
	Temperature class:	T6 (<85°C)
	Max. Power consumption:	5100 mW at 30 Vdc
	Max. Internal capacitance:	187 nF
	Internal inductance:	negligible

**DECLARATION OF CONFORMITY**  
We DATASENSOR S.p.A. declare under our sole responsibility that these products are conform to the 2004/108/CE, 2006/95/CE Directives and successive amendments.



**WARRANTY**  
DATASENSOR S.p.A. warrants its products to be free from defects. DATASENSOR S.p.A. will repair or replace, free of charge, any product found to be defective during the warranty period of 36 months from the manufacturing date. This warranty does not cover damage or liability deriving from the improper application of DATASENSOR products.

DATASENSOR S.p.A. Via Lavino 265  
40050 Monte S. Pietro - Bologna - Italy  
Tel: +39 051 6765611 Fax: +39 051 6759324  
http://www.datasensor.com e-mail: info@datasensor.com

DATASENSOR S.p.A. cares for the environment: 100% recycled paper.  
DATASENSOR S.p.A. reserves the right to make modifications and improvements without prior notification.



## S80-MH-5-YL09

Distance sensor with laser emission and time of flight measurement

### INSTRUCTION MANUAL



### CONTROLS

#### FRONT INDICATORS LED

#### OUTPUT LED

The yellow LED ON indicates the OR function of the OUT1 and OUT2 outputs (one of the 2 outputs is active).

#### ALARM LED

The red LED ON indicates the absence of signal.

#### COMMAND PANEL AND DISPLAY

#### OUTPUT LED

The yellow LED ON indicates the logic OR function of the two OUT1 and OUT2 outputs (one of the 2 outputs is active).

#### DISPLAY (4-digit green coloured display)

In the normal mode, the display indicates the detected distance, in millimetres. The "LLLL" message on display means distance under the minimum value. The "HHHH" message on display means distance over the maximum value. The "FFFF" message on display means low signal received condition.

#### OUT1, OUT2 LEDs

The n.1 and n.2 green LEDs ON indicate the activation of the OUT1 and OUT2 outputs.

#### LED 3

The n.3 green LED does not indicate any function.

#### SET PUSHBUTTON

A pressure on the pushbutton allows the selection of one of the following options:

- measurement range teach-in
- switching thresholds teach-in
- setting and visualisation parameters menu

#### +/- PUSHBUTTONS

A light pressure on these pushbuttons allows the user to run through the menu of the sensor parameters and setting menu.

Moreover, a long pressure allows to change the switching threshold value, as indicated in the "SWITCHING THRESHOLD ADJUSTMENT" paragraph.

### INSTALLATION

The sensor can be positioned by means of the three housing's holes using screws (M5x40 or longer) with nuts and washers. Various orientable fixing brackets to ease the sensor positioning are available (please refer to the accessories listed in the catalogue). The operating distance is measured from the front surface of the sensor optics. The M12 connector can be oriented at two different positions (refer to figure).



### CONNECTIONS

#### M12 CONNECTOR

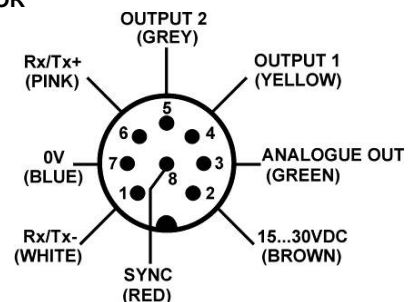

NOTE: the wire colours are referred to the cables manufactured according to the European standard.

### TECHNICAL DATA

Power supply:	15 ... 30 Vdc limit values
Ripple:	2 Vpp max.
Consumption (output current excluded):	170 mA max (110 mA @ 24 V)
Outputs:	2 PNP or NPN outputs 30 Vdc max. (short-circuit protection) analogue output with 4-20 mA
Serial interface:	RS485, 9600Bd, 8N1
SYNC input:	PNP
Measurement range:	300 ... 7000 mm (90% white) 300 ... 4000 (18% grey) 300 ... 2500 mm (6% black)
Linearity:	0.3% (24Vdc, 25°C, with 90% white target)
Repeatability:	7 mm @ 7m
Hysteresis:	5 mm
Temperature drift:	< 0.6 mm/°C
Output current:	100 mA max.
Output saturation voltage:	≤ 2 V
Response time:	6 ms
Switching frequency:	85 HZ
Indicators:	<b>command panel:</b> 4-digit display (GREEN), OUTPUT LED (YELLOW) 2 OUT1, OUT2 LEDs (GREEN) <b>Indicators LED:</b> OUTPUT LED (YELLOW) / ALARM LED (RED)
Setting:	SET, +, - pushbuttons
Data retention:	non volatile EEPROM memory
Operating temperature:	-10 ... 50 °C
Storage temperature:	-20 ... 70 °C
Electrical shock protection:	Class 2
Typical spot dimension:	∅ 12 mm at 2 m ∅ 20 mm at 4 m ∅ 40 mm at 6 m
Emission type:	Red laser (665 nm) Class 2 (λ. 665 nm) EN 60825-1 (1994)
Ambient light rejection:	According to EN 60947-5-2
Vibrations:	0.5 mm amplitude, 10 ... 55 Hz frequency, for every axis (EN60068-2-6)
Shock resistance:	11 ms (30 G) 6 shock for every axis (EN60068-2-27)
Housing material:	aluminium
Lens material:	Window and lenses in glass
Mechanical protection:	IP67
Connections:	M12-8 pole connector
Weight:	330 g. max.

### DIMENSIONS

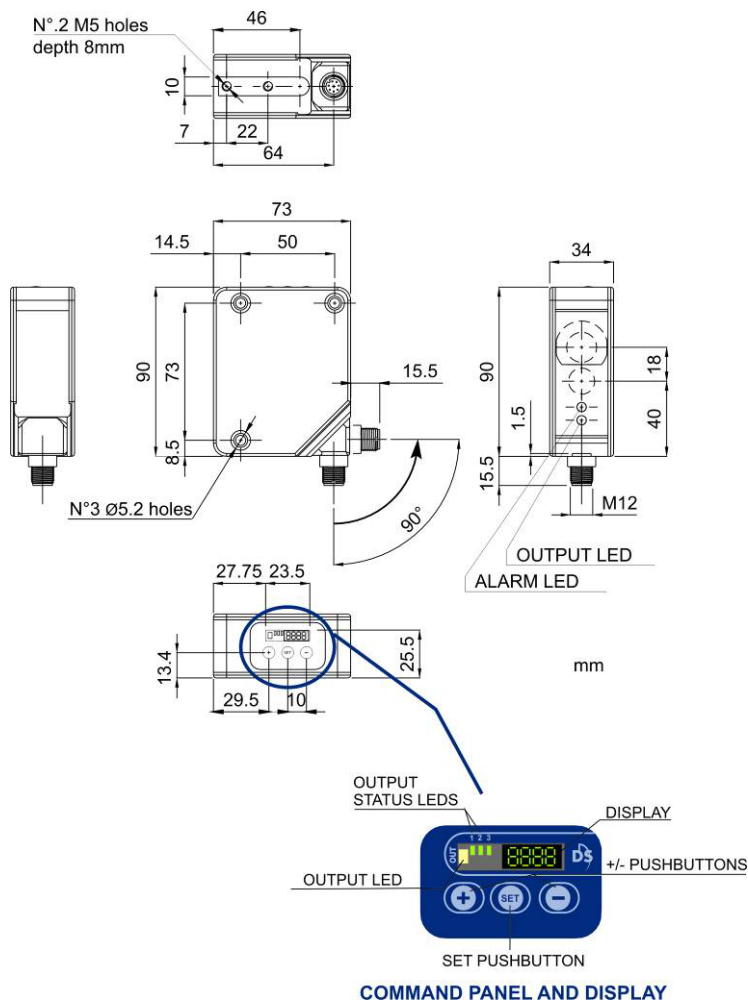

### MEASUREMENT RANGE TEACH-IN

Legend: ● pushbutton pressed ○ pushbutton not pressed  
■ LED on □ LED off

Measurement range teach-in is effected placing directly the object to detect in front of the sensor, according to the following procedure:

#### - Detection

- Place the object in front of the sensor to distance that is to be detected detect as minimum or maximum distance

OR	1	2	3	Dig1	Dig2	Dig3	Dig4	+	SET	-
■	□	■	□	1	9	4	5	○	●	○

- Press the SET pushbutton for at least 4s, until the "d\_Lo" message appears.

OR	1	2	3	Dig1	Dig2	Dig3	Dig4	+	SET	-
□	□	□	□	d	-	L	o	○	○	○

#### - Minimum - Maximum distance selection:

- +/- buttons pressure permits to select among following options:

1. minimum distance ("d\_Lo")
2. maximum distance ("d\_HI")
3. range selection menu exit, without saving any values ("ESC")
4. restoring of the standard measurement range, 300 mm - 7000 mm ("rES")

OR	1	2	3	Dig1	Dig2	Dig3	Dig4	+	SET	-
□	□	□	□	d	-	L	o	●	○	●

OR	1	2	3	Dig1	Dig2	Dig3	Dig4	+	SET	-
□	□	□	□	d	-	H	I	○	○	○

OR	1	2	3	Dig1	Dig2	Dig3	Dig4	+	SET	-
□	□	□	□	E	S	C	-	○	○	○

OR	1	2	3	Dig1	Dig2	Dig3	Dig4	+	SET	-
□	□	□	□	r	E	S	-	○	○	○

#### - Exit without saving any values

- To exit the menu without saving any value select "ESC"  
- Push the SET button for at least 0.5s

#### - Exit restoring the standard range 300mm - 7000mm

- To exit the menu restoring the standard range 300 mm - 7000mm select "rES"  
- Push the SET pushbutton for at least 0.5s

#### - Target detection phase

- Selec "d\_Lo" or "d\_HI" options  
- Push the SET pushbutton for at least 0.5s.  
- The "uPdt" message begins to blink (4Hz, per 3 s).

OR	1	2	3	Dig1	Dig2	Dig3	Dig4	+	SET	-
□	□	□	□	u	P	d	t	○	○	○

- Detection distance value appears.

- The +/- pushbuttons can be used to change the detected distance value.

OR	1	2	3	Dig1	Dig2	Dig3	Dig4	+	SET	-
■	□	■	□	1	9	4	5	○	○	○

- The units change if these pushbuttons are pressed repeatedly, the tens if kept pressed.

- Press the SET pushbutton again for at least 0.5s to end the detection phase.

OR	1	2	3	Dig1	Dig2	Dig3	Dig4	+	SET	-
■	□	■	□	1	9	4	5	○	○	○

### SETTING OF THE 2 CHANNELS

Legend: ● pushbutton pressed ○ pushbutton not pressed  
■ LED on □ LED off

The switching threshold setting for each of the 2 channels and the selection of the logic switching is effected placing directly the object to detect in front of the sensor, according to the following procedure:

#### - Detection

- Place the object to detect in front of the sensor.

OR	1	2	3	Dig1	Dig2	Dig3	Dig4	+	SET	-
■	□	■	□	1	9	4	5	○	○	○

- Press the SET pushbutton for at least 2 s.

- The "CH-1" message appears.

OR	1	2	3	Dig1	Dig2	Dig3	Dig4	+	SET	-
□	□	□	□	C	H	-	1	○	○	○

#### - Channel selection

- To select the channel setting use the +/- pushbuttons.

OR	1	2	3	Dig1	Dig2	Dig3	Dig4	+	SET	-
□	□	□	□	C	H	-	1	○	○	○

OR	1	2	3	Dig1	Dig2	Dig3	Dig4	+	SET	-
□	□	□	□	C	H	-	2	○	○	○

OR	1	2	3	Dig1	Dig2	Dig3	Dig4	+	SET	-
□	□	□	□	E	S	C	-	○	○	○

#### - Exit without saving any value

- To exit the menu select "ESC" without saving any value select "ESC"  
- Push the SET button for at least 0.5s

#### - Switching threshold teach-in: DARK/LIGHT selection

- Select "CH1" or "CH2" options  
- Press the SET pushbutton again for at least 0.5 s.  
- The "L On" message appears.

OR	1	2	3	Dig1	Dig2	Dig3	Dig4	+	SET	-
□	□	□	□	L	O	n	○	○	○	○

- To select the DARK/LIGHT mode of the channel use the +/- pushbuttons.  
- "L on" is visualised when the LIGHT mode is selected; "d On" in case of DARK mode

OR	1	2	3	Dig1	Dig2	Dig3	Dig4	+	SET	-
□	□	□	□	L	O	n	○	○	○	○

OR	1	2	3	Dig1	Dig2	Dig3	Dig4	+	SET	-
□	□	□	□	d	O	n	○	○	○	○

#### - Target detection phase

- Press the SET pushbutton for at least 0.5 s, the "uPdt" message begins to blink (4Hz, for 2 s).

OR	1	2	3	Dig1	Dig2	Dig3	Dig4	+	SET	-
□	□	□	□	u	P	d	t	○	○	○

- The detection distance value appears.

- The +/- pushbuttons can be used to change the detected distance value.

OR	1	2	3	Dig1	Dig2	Dig3	Dig4	+	SET	-
■	□	■	□	1	9	4	5	○	○	○

- The units change if these pushbuttons are pressed repeatedly, the tens if kept pressed.

- Press the SET pushbutton again for at least 0.5 s. to end the detection phase.

OR	1	2	3	Dig1	Dig2	Dig3	Dig4	+	SET	-
■	□	■	□	1	9	4	5	○	○	○

### SWITCHING THRESHOLD ADJUSTMENT

OR	1	2	3	Dig1	Dig2	Dig3	Dig4	+	SET	-
■	□	■	□	1	9	4	5	○	○	○

- Press the +/- pushbuttons for at least 2 s.

- The "CH-1" message appears.

OR	1	2	3	Dig1	Dig2	Dig3	Dig4	+	SET	-
■	□	■	□	C	H	-	1	○	○	○

#### - Channel selection

- Use the +/- pushbuttons to select the channel to detect.

OR	1	2	3	Dig1	Dig2	Dig3	Dig4	+	SET	-
■	□	■	□	C	H	-	1	○	○	○

OR	1	2	3	Dig1	Dig2	Dig3	Dig4	+	SET	-
■	□	■	□	C	H	-	2	○	○	○

#### - Distance of threshold phase

- Press the SET pushbutton for at least 0.5 s.

- The previously detected distance value appears.

- Use the +/- pushbuttons to change the detected distance value.

- The units change if these pushbuttons are pressed repeatedly, the tens if kept pressed.

OR	1	2	3	Dig1	Dig2	Dig3	Dig4	+	SET	-
■	□	■	□	1	9	4	5	○	○	○

- Press the SET pushbutton again for at least 0.5 s. to end the adjustment phase.

OR	1	2	3	Dig1	Dig2	Dig3	Dig4	+	SET	-
■	□	■	□	1	9	6	0	○	○	○

## SETTING OF THE PARAMETERS

OR	1	2	3	Dig1	Dig2	Dig3	Dig4	+	SET	-
<input type="checkbox"/>	<input type="checkbox"/>	<input type="checkbox"/>	<input type="checkbox"/>	1	9	4	5	○	●	○

Press the SET pushbutton for at least 8s to enter into the parameter setting menu.  
The "MEnu" message appears.

OR	1	2	3	Dig1	Dig2	Dig3	Dig4	+	SET	-
<input type="checkbox"/>	<input type="checkbox"/>	<input type="checkbox"/>	<input type="checkbox"/>	M	E	n	u	○	○	○

Pressing the + and - pushbuttons the user and run up and down the menu, reading the following messages.

### Maximum distance visualization

- At each pressure of the SET pushbutton, the user can run through the options of the selected level.

OR	1	2	3	Dig1	Dig2	Dig3	Dig4	+	SET	-
<input type="checkbox"/>	<input type="checkbox"/>	<input type="checkbox"/>	<input type="checkbox"/>	D	-	H	I	○	●	○
DISTANZA				7	0	0	0			

### Minimum distance visualization

- At each pressure of the SET pushbutton, the user can run through the options of the selected level.

OR	1	2	3	Dig1	Dig2	Dig3	Dig4	+	SET	-
<input type="checkbox"/>	<input type="checkbox"/>	<input type="checkbox"/>	<input type="checkbox"/>	d	-	L	o	○	○	○
DISTANZA				0	3	0	0			

### Delay setting

- At each pressure of the SET pushbutton, the user can run through the options of the selected level.

OR	1	2	3	Dig1	Dig2	Dig3	Dig4	+	SET	-
<input type="checkbox"/>	<input type="checkbox"/>	<input type="checkbox"/>	<input type="checkbox"/>	d	-	0	0	○	●	○
DISTANZA				d	-	0	5			
				d	-	1	0			
				d	-	2	0			
				d	-	3	0			
				d	-	4	0			

- The delay value setting is in common to both outputs.  
- When a delay value, different from zero, is set, the outputs will be maintained active for a minimum time equal to the number of milliseconds visualised on the display.

### Visualisation of the channel 1 data

- At each pressure of the SET pushbutton, the user can run through the options of the selected level.

OR	1	2	3	Dig1	Dig2	Dig3	Dig4	+	SET	-
<input type="checkbox"/>	<input type="checkbox"/>	<input type="checkbox"/>	<input type="checkbox"/>	C	H	-	1	○	○	○
THRESHOLD				1	9	4	5			
MODE				L/d	-	O	n			

### Visualisation of the channel 2 data

At each pressure of the SET pushbutton, the user can run through the options of the selected level.

OR	1	2	3	Dig1	Dig2	Dig3	Dig4	+	SET	-
<input type="checkbox"/>	<input type="checkbox"/>	<input type="checkbox"/>	<input type="checkbox"/>	C	H	-	2	○	○	○
THRESHOLD				1	9	4	5			
MODE				L/d	-	O	n			

### Serial output deactivation

At each pressure of the SET pushbutton, the user can run through the options of the selected level.

OR	1	2	3	Dig1	Dig2	Dig3	Dig4	+	SET	-
<input type="checkbox"/>	<input type="checkbox"/>	<input type="checkbox"/>	<input type="checkbox"/>	S	-	o	n	○	○	○
DISTANZA				S	-	o	f			

### Memorisation of the parameters set

OR	1	2	3	Dig1	Dig2	Dig3	Dig4	+	SET	-
<input type="checkbox"/>	<input type="checkbox"/>	<input type="checkbox"/>	<input type="checkbox"/>	S	A	V	E	○	○	○
DISTANZA				S	A	V	E			

- Pressing the SET pushbutton (the SAVE message blinks for 2s, 4Hz) all the changed values are saved and the user exits from the menu, and returns to the normal mode.  
- One of the +/- pushbuttons has to be pressed to return to the setting menu.

### Exit from the parameter setting menu

After a 10 s inactivity of the pushbuttons, the sensor returns to the normal mode visualising the distance.

## REMOTE FUNCTION

### KEYLOCK function (SET pushbutton block)

The keyboard block function is activated at powering on, connecting the SYNC terminal to the positive power supply (+Vdc) for at least 1 s.  
After the first second, the SYNC input is ready for the normal synchronisation operations (refer to next paragraph).  
To deactivate the keyboard block, the sensor has to be turned off and re-powered maintaining the SYNC wire not connected or ground connected (GND).

### SYNC input (synchronisation)

The connection of the SYNC wire to +Vdc corresponds to the passive logic status while SYNC not connected or connected to 0 V corresponds to the active logic status.

SYNC passive = +Vdc ; SYNC active = 0V

The synchronisation signal allows to calculate the beginning and ending instants of the measurement. The reading cycle begins after the transition of the SYNC signal from passive to active and the sensor outputs are updated after max. 400µs.  
All the outputs are deactivated after max. 400µs from the active - passive transition.

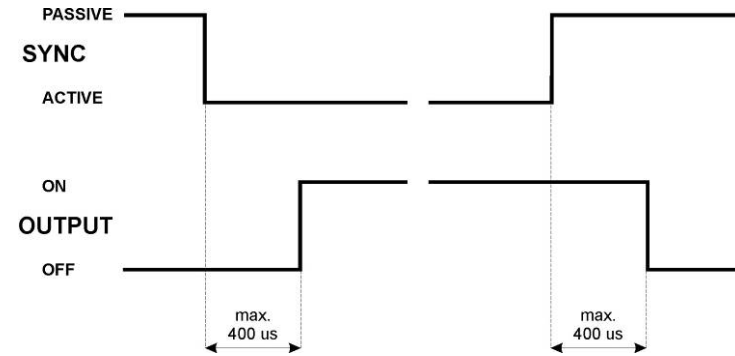

The SYNC wire is used also to determine the transmission direction when the RS485 serial connection is used.

### RS485 serial connection

The serial communication parameters are: 9600 baud, non-parity, 8 data bits, 1 stop bit.  
The refresh time of the serial port is 15ms.  
The SYNC input is used to determine the communication direction, and in particular if low (active) direction S80->User, if high (passive) User->S80.  
With SYNC active, the sensor continuously transmits the detected distance value (with a precision of 14bit) by means of a binary data format. 3 byte are used; one with bit 0 at logic level 1 identifies the most important byte, second with bit 6 at logic level 1 and bit 7 at logic level 0 identifies intermediate byte, third with bit 6 at logic level 1 and bit 7 at logic level 1 identifies more important byte.



Low signal received condition, corresponding to "FFFF" display indication, is represented on RS485 serial connection by the following sequence:



Out of range condition, corresponding to "HHHH" or "LLLL" display indication, is represented on RS485 serial connection by the following sequence:

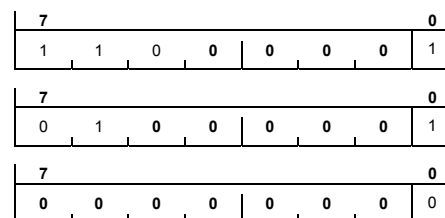

The RS485 serial interface allows also the complete remote control of the sensor. All the commands have to be sent via terminal in an ASCII format according to the following:

### Receipt of the channel status:

At any moment, at the receipt of the 'r <CR> <LF>' remote command (and SYNC passive), the sensor configuration is restored.

### Remote configuration:

The commands available are:

@ <CR> <LF> beginning of the remote setting mode (and SYNC passive)  
c1 <CR> <LF> channel 1 selection  
vxxx <CR> <LF> distance selection, with xxx ∈ {0...4095}  
bx <CR> <LF> dark/light mode selection, with x ∈ {1, 2}  
b1 = Dark  
b2 = Light

e <CR> <LF> memorisation of the configuration sequence.  
q <CR> <LF> exit from remote setting without saving the configuration.

At the receipt of the q <CR> <LF> or e <CR> <LF> commands, the sensor visualises ok <CR> <LF>.

### Delay configuration:

The commands available are:

@ <CR> <LF> beginning of the delay configuration (and SYNC passive)  
dx <CR> <LF> delay selection, with x ∈ {0, 1, 2, 3, 4, 5}  
d0 = 0 ms d3 = 20 ms  
d1 = 5 ms d4 = 30 ms  
d2 = 10 ms d5 = 40 ms

e <CR> <LF> memorisation of the new delay value  
q <CR> <LF> exit from the delay configuration without saving the configuration.

At the receipt of the q <CR> <LF> or e <CR> <LF> commands, the sensor visualises ok <CR> <LF>.

NOTE: the single digits have to be distanced amongst themselves at least 1 ms, during the command transmission.

## DETECTION DIAGRAMS

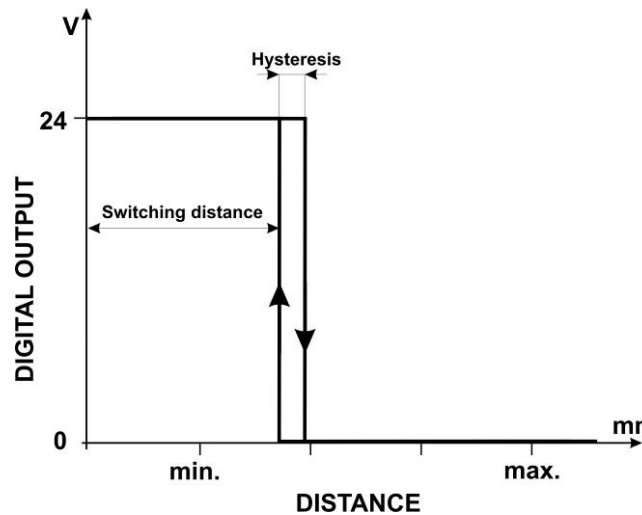
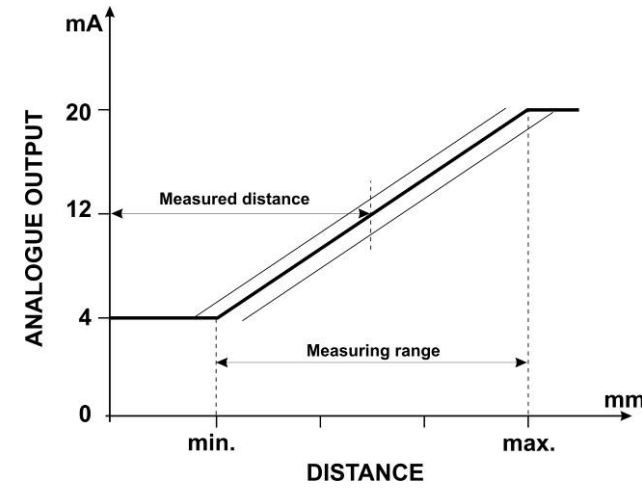

## SAFETY WARNINGS

All the safety electrical and mechanical regulations and laws have to be respected during sensor functioning. The sensor has to be protected against mechanical damages.  
Place the given labels in a visible position close to the laser emission.



Do not look directly into the laser beam!  
Do not point the laser beam towards people!  
Eye irradiation for over 0.25 seconds is dangerous; refer to class 2 standard (EN60825-1).  
These sensors are not conform to safety applications!

	<b>EX-II-3-D T6</b>	
	Temperature class:	T6 (<85°C)
	Max. Power consumption:	5100 mW at 30 Vdc
	Max. Internal capacitance:	187 nF
	Internal inductance:	negligible

**DECLARATION OF CONFORMITY**  
We DATASENSOR S.p.A. declare under our sole responsibility that these products are conform to the 2004/108/CE, 2006/95/CE Directives and successive amendments.

**WARRANTY**  
DATASENSOR S.p.A. warrants its products to be free from defects.  
DATASENSOR S.p.A. will repair or replace, free of charge, any product found to be defective during the warranty period of 36 months from the manufacturing date.  
This warranty does not cover damage or liability deriving from the improper application of DATASENSOR products.

DATASENSOR S.p.A. Via Lavino 265  
40050 Monte S. Pietro - Bologna - Italy  
Tel: +39 051 6765611 Fax: +39 051 6759324  
http://www.datasensor.com e-mail: info@datasensor.com

DATASENSOR S.p.A. cares for the environment: 100% recycled paper.  
DATASENSOR S.p.A. reserves the right to make modifications and improvements without prior notification.