

## INDEX

<b>1. GENERAL INFORMATION</b> .....	<b>1</b>
1.1. General description of the SAFEasy™ safety light curtain .....	1
1.2. General features.....	4
1.3. Typical applications.....	6
1.4. Safety information .....	7
<b>2. INSTALLATION MODE</b> .....	<b>8</b>
2.1. Precautions to respect for the choice and installation of the device .....	8
2.2. General information on device positioning .....	9
2.2.1. <i>Minimum installation distance</i> .....	9
2.2.2. <i>Minimum distance from reflecting surfaces</i> .....	10
2.2.3. <i>Installation of several adjacent safety light curtains</i> .....	12
2.2.4. <i>Precautions to respect during the use of deviating mirrors</i> .....	13
<b>3. MECHANICAL MOUNTING</b> .....	<b>13</b>
3.1. Mounting of active unit .....	13
3.2. Deviating mirror mounting .....	15
3.3. Mounting of passive unit.....	17
3.4. Mounting of mechanical arms .....	19
<b>4. ELECTRICAL CONNECTIONS</b> .....	<b>21</b>
4.1. Notes on connections.....	22
<b>5. ALIGNMENT PROCEDURE</b> .....	<b>26</b>
5.1. Correct light curtain alignment procedure of single mirrors.....	26
5.2. Guide to correct alignment procedure of passive unit.....	27
5.3. Guide to correct alignment procedure of Muting arms .....	29
<b>6. FUNCTIONING MODE</b> .....	<b>30</b>
<b>6. FUNCTIONING MODE</b> .....	<b>30</b>
6.1. Dip-switch selectable functions .....	30
6.2. Standard configuration .....	30
6.3. Restart mode.....	31
6.4. Reset function .....	33
6.5. Muting function .....	34
6.6. Muting function .....	37
6.6.1. <i>Applications</i> .....	38
6.6.2. <i>SE4-L model</i> .....	41
6.6.3. <i>SE4-T model</i> .....	42
6.7. Override function .....	43
6.8. EDM function.....	46
<b>7. DIAGNOSTIC FUNCTIONS</b> .....	<b>47</b>
7.1. Visualisation of the functions.....	47
7.2. Alignment control.....	48
7.3. Operating mode.....	48
7.4. Fault and diagnostic messages.....	49
<b>8. CHECKS AND PERIODICAL MAINTENANCE</b> .....	<b>50</b>
8.1. Maintenance.....	51
8.2. General information and useful data .....	51
8.3. Warranty.....	52
<b>9. TECHNICAL DATA</b> .....	<b>53</b>
<b>10. DIMENSIONS</b> .....	<b>54</b>
<b>11. ACCESSORIES</b> .....	<b>56</b>

## 1. GENERAL INFORMATION

### 1.1. General description of the SAFEasy™ safety light curtain

The **SAFEasy™** safety light curtain of the SE4-R Series, is an optoelectronic multibeam device, that can be used to protect working area that, in presence of machines, robots, and automatic systems in general, can become dangerous for operators that get in touch, even accidentally, with moving parts.

The **SAFEasy™** light curtains of the SE4-R Series are Type 4 intrinsic safety systems used as accident-prevention protection devices and are manufactured in accordance with the international Standards in force for safety, in particular:

**CEI IEC 61496-1: 2004** Safety of machinery:  
electro-sensitive protective  
equipment. Part 1: General  
requirements and tests.

**CEI IEC 61496-2: 1997** Safety of machinery:  
electro-sensitive protective  
equipment. Particular  
requirements for equipment  
using active optoelectronic  
protective devices.

The device, consisting in one active unit inside a sturdy aluminium profile and a passive unit composed of two deviating mirrors, generates a couple of infrared beams able to detect an opaque object positioned within the light curtain detection field.

The active unit is composed of two optic groups: an emitting and a receiving unit. The infrared beam, generated by the emitting optic group, is reflected by the deviating mirrors and thus re-guided towards the receiving optic group of the active unit.

Two configurations for the passive unit are available: a composite system composed of two mirrors mounted on separate supports (Fig. 1); and a sturdy aluminium profile containing two pre-assembled and pre-aligned mirrors (Fig. 2).

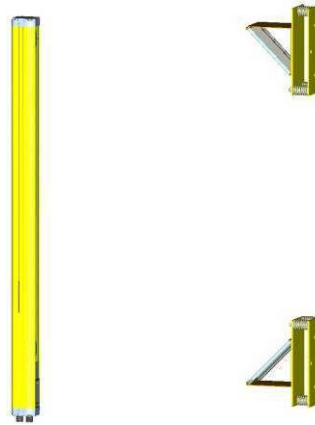

Fig. 1

For the configuration with passive mirrors inside the profile, the solution with integrated Muting arms can be implemented both in a 'T' or 'L' configuration.

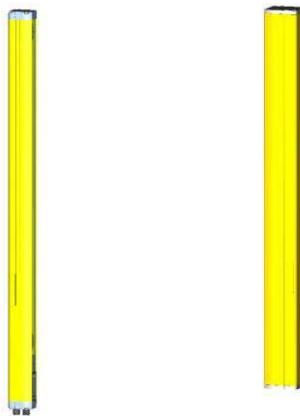

Fig. 2

English

The command and control functions are available inside the active unit. The connections are made through two M12 connectors located in the lower side of the profile.

The microprocessors guarantee the check and the management of the beams that are sent and received through the units: the microprocessors – through some LEDs – inform the operator about the general conditions of the light curtain and about eventual faults (see section 7 “Diagnostic functions”).

As soon as an object, a limb or the operator’s body accidentally interrupts the beams sent by the emitter, the receiver immediately opens the OSSD outputs and blocks the machine (if correctly connected to the OSSD).

**Note:** *The following abbreviations, defined by the standards in force, will be used in this manual:*

**AOPD** *Active opto-electronic protective device*

**ESPE** *Electro-sensible protective equipment*

**OSSD** *Output signal switching device (switching output)*

**TX** *Emitting device*

**RX** *Receiving device*

**EDM** *External device monitoring*

Some parts or sections of this manual containing important information for the operator are preceded by a note:



Notes and detailed descriptions about particular characteristics of the **SAFEasy™** safety devices in order to better explain their functioning; special instructions regarding the installation process. The information provided in the paragraphs following this symbol is very important for safety and may prevent accidents.



Always read this information accurately and carefully follow the advice to the letter.

This manual contains all the information necessary for the selection and operation of the **SAFEasy™** safety devices.

However, specialised knowledge not included in this technical description is required for the planning and implementation of a safety light curtain on a power-driven machine.

As the required knowledge may not be completely included in this manual, we suggest the customer to contact DATASENSOR Sales Technical Service for any necessary information relative to the functioning of the SE4-R Series light curtains and the safety rules that regulate the correct installation (see section 8 “Checks and periodical maintenance”).

## 1.2. General features

The SE4-R light curtains efficiently satisfy all applications that require the Muting function thanks to specific Muting sensor inputs.

There are at least three different main characteristics that should be considered when choosing a safety light curtain:

- **The resolution** strictly depending on the part of the body to be protected.



The resolution of the device is the minimum dimension, which an opaque object must have in order to obscure at least one of the beams that constitute the sensitive area.

As shown in Fig. 3, the resolution only depends on the geometrical characteristics of the lenses, diameter and distance between centres, and is independent of any environmental and operating conditions of the safety light curtain.

The resolution value is obtained applying the following formula:

$$R = I + d$$

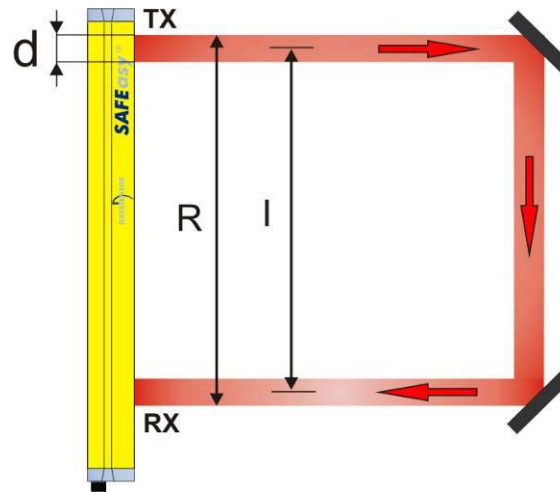

Fig. 3

English

The following table shows the values of the optic interaxis (**I**), the resolution (**R**) and the optic diameter (**d**), of the safety light curtains.

Model	Optic interaxis <i>mm</i> ( <b>I</b> )	N°. Optics ( <b>n</b> )	Resolution <i>mm</i> ( <b>R</b> )	Optics Ø <i>mm</i> ( <b>d</b> )	Operating distance <i>m</i>
SE4-RA1-PP-W	500	2	515	16	7.5
SE4-RA1L-PP-W	500	2	515	16	3
SE4-RA1T-PP-W	500	2	515	16	3

**Note:** Safety light curtains for body protection with sensitive area heights and optic interaxis different from the standard versions can be manufactured upon specific request.

- The height of the protected area  
It is important to distinguish between “Height of the sensitive area” and “Height of the controlled area” (Fig. 4).
  - The height of the sensitive area is the distance between the lower and the upper limits respectively of the first and the last lens.
  - The height of the controlled area is the effectively protected area; it delimits the area where an opaque object with larger or equal dimensions respect to the resolution of the safety light curtain may certainly cause the interruption of a beam.

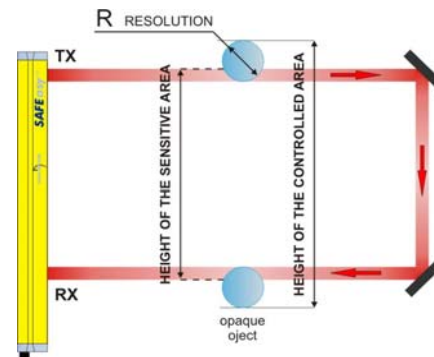

Fig. 4

- The safety distance  
It is important to carefully calculate the distance between the point where the safety device will be placed and the possible danger associated with the machine to be protected (see section 2 “Installation mode” for the calculation of the safety distance).

### 1.3. Typical applications

The **SAFEasy**<sup>™</sup> safety light curtains of the SE4-R Series are used in all automation fields where control and protection of the access to dangerous zones is necessary, as well as allowing, by means of the Muting function, material passage inside a dangerous zone during working.

In particular they are used to stop the moving mechanical parts in:

- Access control
- Working areas
- Packaging machines, handling machines, storing machines;
- Automatic and semi-automatic assembly lines;
- Automatic warehouses;
- Robotics.



In food industry applications, DATASENSOR Technical Service has to verify the compatibility of the material of the safety light curtain housing with any chemical agents used in the production process.

The following pictures show some main applications.

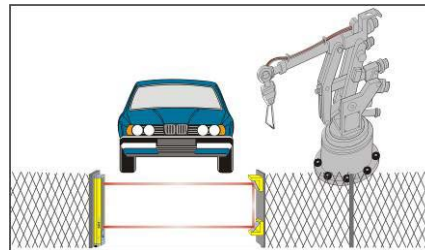

*Robotised assembly lines*

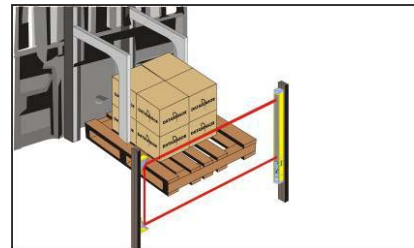

*Transfer areas*

#### 1.4. Safety information



The following points must be observed for a correct and safe use of the **SAFEasy™** safety light curtains of the SE4-R Series:

- The stopping system of the machine must be electrically controlled.
- This control system must be able to instantly stop the dangerous movement of the machine during all the phases of the working cycle.
- Mounting and connection of the safety light curtain must only be carried-out by qualified personnel, according to the indications included in the special sections (refer to sections 2; 3; 4; 5; 6).
- The safety light curtain must be securely placed in a particular position so that access to the danger zone is not possible without the interruption of the beams (see section 2 “Installation mode”).
- The personnel operating in the dangerous area must be well trained and must have adequate knowledge of all the operating procedures of the safety light curtain.
- The TEST/START button must be located outside the protected area because the operator must check the protected area during all the Test, Override and Reset operations.
- The built-in signalling lamp of the active Muting must be visible from all operating sides.
- Please carefully respect the mounting instructions for the correct functioning of the Muting devices.
- The function of the external device monitoring (EDM) is active only if the specific wire is correctly connected to the device. Please carefully read the instructions for the correct functioning before powering the light curtain.

## 2 INSTALLATION MODE

### 2.1. Precautions to respect for the choice and installation of the device



- Make sure that the protection level assured by the **SAFEasy™** (Type 4) is compatible with the real danger level of the machine to be controlled, according to EN 954-1.
- The outputs (OSSD) of the ESPE must be used as machine stopping devices and not as command devices. The machine must have its own START command.
- The dimension of the smallest object to be detected must be larger than the resolution level of the ESPE.
- The ESPE must be installed respecting the technical characteristics indicated in section 9.
- Do not place the device, in particular the receiving optics, near intense light sources.
- Strong electromagnetic interferences can compromise the correct functioning of the device. DATASENSOR suggests contacting its own Technical Service when this problem occurs.
- The operating distance of the device can be reduced in presence of smog, fog or airborne dust
- Strong vibrations and shocks can jeopardise the alignment of the two units, especially if the units are positioned near the maximum operating distance allowed.
- A sudden change in environment temperature, with very low minimum peaks, can generate a small condensation layer on the lenses and so jeopardise functioning.
- The Muting function is signalled by a specific Muting signalling lamp. Ensure that the signalling device has sufficient lighting and visibly positioned near the dangerous zone.
- Ensure to correctly use Muting sensors as described in the instructions supplied hereinafter. Avoid incongruent connections that cannot be controlled and thus excluding undesired potentially dangerous activations.

## 2.2. General information on device positioning

### 2.2.1. Minimum installation distance

The safety device must be placed at a specific safety distance (Fig. 5). This distance must ensure that the danger zone cannot be reached before the dangerous motion of the machine has been stopped by the ESPE.

The safety distance depends on 4 factors, according to the EN-999, 775 and 294 Standards:

- 1 Response time of the ESPE (the time between the effective beam interruption and the opening of the OSSD contacts).
- 2 Machine stopping time (the time between the effective opening of the contacts of the ESPE and the real stop of the dangerous movement of the machine).
- 3 ESPE resolution.
- 4 Approaching speed of the object to be detected.

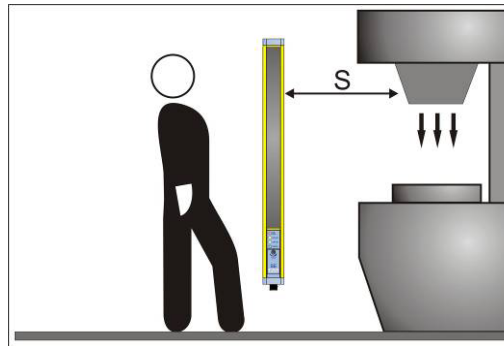

Fig. 5

The following formula is used for the calculation of the safety distance:

$$S = K (t_1 + t_2) + C$$

where:

**S** = Minimum safety distance in mm.

**K** = Speed of the object, limb or body approaching the dangerous area in mm/sec.

**t<sub>1</sub>** = Response time of the ESPE in seconds (see section 9 "Technical data")

**t<sub>2</sub>** = Machine stopping time in seconds.

**d** = Resolution of the system.

**C** = 850 mm for device with resolution > 40mm.

**Note:** The value of K is:

2000 mm/s if the calculated value of S is  $\leq 500$  mm

1600 mm/s if the calculated value of S is  $> 500$  mm

### 2.2.2. Minimum distance from reflecting surfaces

Reflecting surfaces placed near the light beams of the **SAFEasy™** device (over, under or laterally) can cause passive reflections. These reflections can compromise the recognition of an object inside the controlled area (see Fig. 6).

However, if the **RX** receiver detects a secondary beam (reflected by the side-reflecting surface) the object might not be detected, even if the object interrupts the main beam.

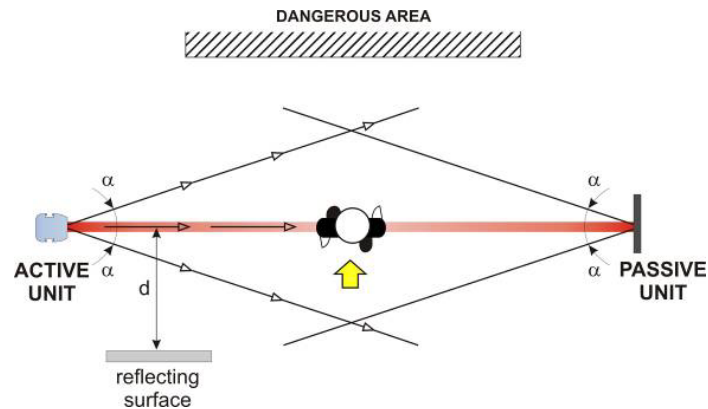

Fig. 6



- It is thus important to position the safety light curtain according to the minimum distance from reflecting surfaces. The minimum distance depends on:
- Operating distance between active and passive units;
- Maximum aperture angle of the light beam emitted by the safety light curtain, depending on the type of the device; in particular:

**5° for ESPE type 4 ( $\pm 2.5^\circ$  as to the optic axis)**

The graphic in Fig. 7 shows the data of the minimum distance

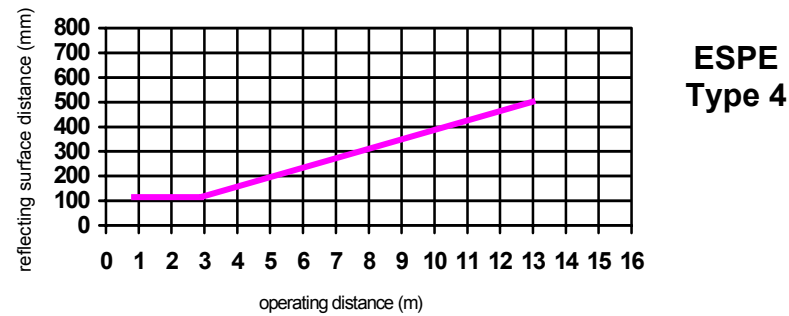

Fig. 7

*in particular:*

$d \geq 100 \text{ mm}$  for  $0.5 \div 3 \text{ m}$  operating distances.

$d \geq 100 \text{ mm} + 40 \text{ mm/m} \times [\text{operating distance (m)} - 3]$  for operating distance  $\geq 3 \text{ m}$ .

Even in presence of beam interruption due to reflecting objects, the correct device functioning is guaranteed and certified up to a maximum operating distance of 7.5 m. The use of the device at higher distances, when possible, is however not recommended. If used, the user must check the correct functioning verifying that no dangerous reflections towards the receiving optics are generated by shiny objects (Fig. 8).

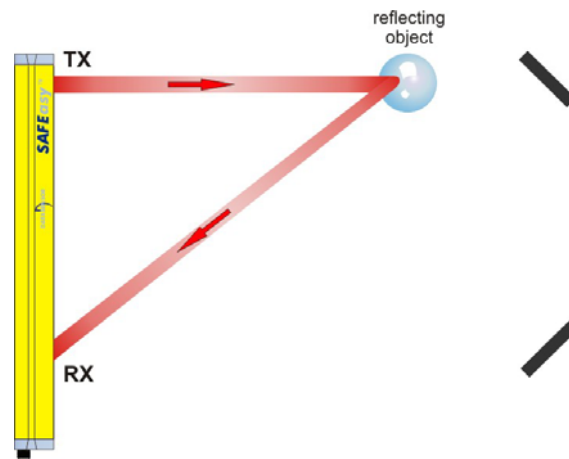

Fig. 8

### 2.2.3. Installation of several adjacent safety light curtains

When several safety devices must be installed in adjacent areas, interferences between the emitter of one device and the receiver of the other must be avoided.

Fig. 9 provides an example of possible interferences between different devices and two pertinent solutions.

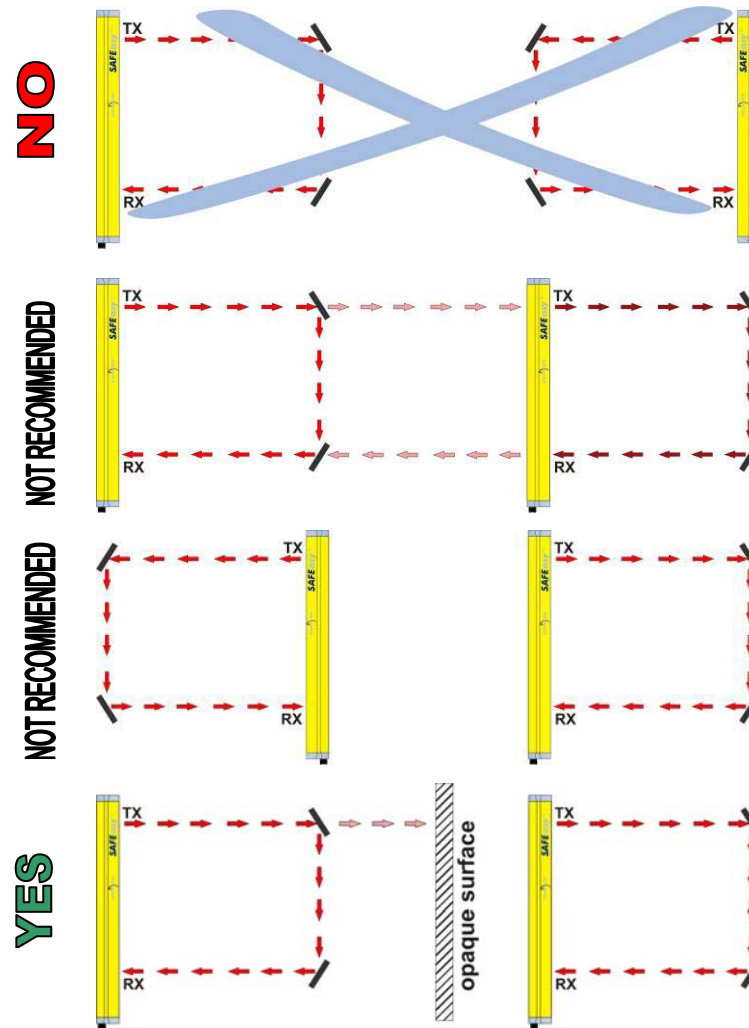

Fig. 9

#### 2.2.4. Precautions to respect during the use of deviating mirrors

The operator must observe the following precautions when using the deviating mirrors:

- ☞ • The alignment of the active unit can become a very critical operation when deviating mirrors are used. Even a very small angular displacement of the mirror is enough to loose alignment. A laser pointer (available as an accessory) can be used to avoid this problem.
- The presence of dust or dirt on the reflecting surface of the mirror causes a drastic reduction in the range.

### 3. MECHANICAL MOUNTING

The active and passive units must be installed with the relevant sensitive surfaces facing each other, within the operating distance of the model used (see section.9 “*Technical data*”).

Once positioned the two units, the two bars should be aligned and parallel as much as possible.

#### 3.1. Mounting of active unit

To mount the active unit, use the threaded pins supplied, inserting them into the slots on the profile (Fig. 10 and Fig. 11).

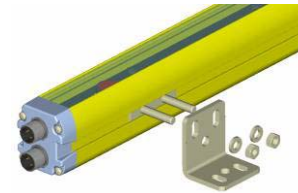

Fig. 10

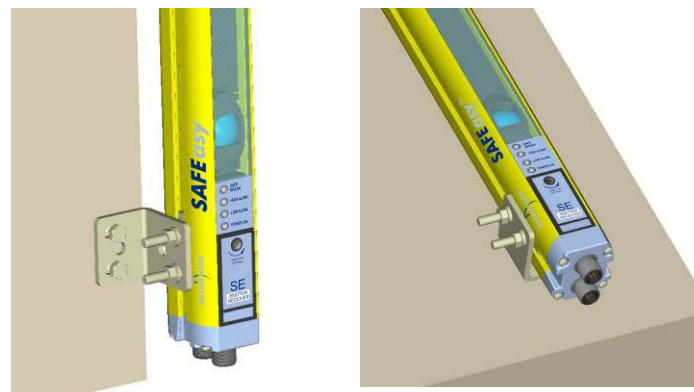

Fig. 11

Fixing brackets can be used where no large mechanical compensation is required during the alignment operation.

The rotating supports for the correction of the bar inclination are available on request (see section 12 "Accessories").

In case of applications with particularly strong vibrations, anti-vibration shock absorbers, together with threaded pins, rigid brackets and/or rotating supports, are recommended to reduce the impact of the vibrations.

The recommended mounting positions according to the safety light curtain length are shown in the following drawings and table:

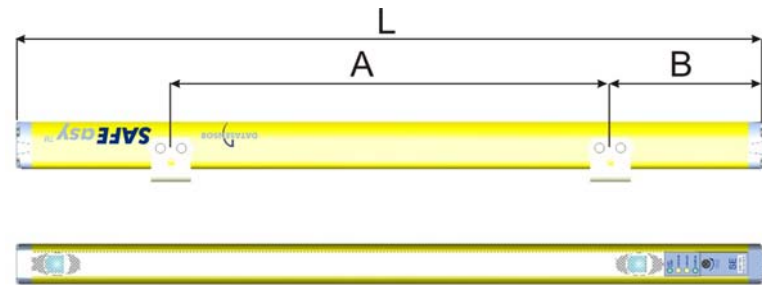

MODEL	L (mm)	A (mm)	B (mm)
SE4-RA1-PP-W	642	342	150
SE4-RA1L-PP-W	642	342	150
SE4-RA1T-PP-W	642	342	150

English

**3.2 Deviating mirror mounting**

The deviating mirrors are composed of the following parts:

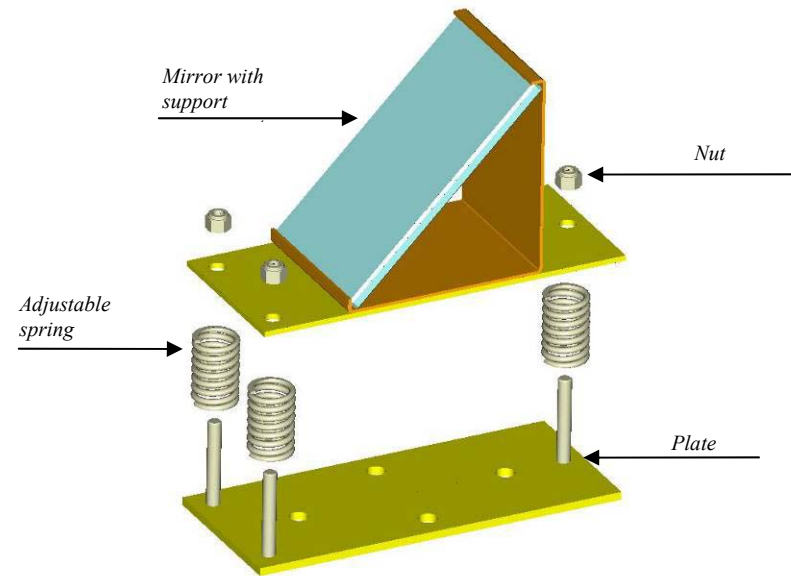

Assembling the single parts, the mirrors be mounted as illustrated in Fig. 12:

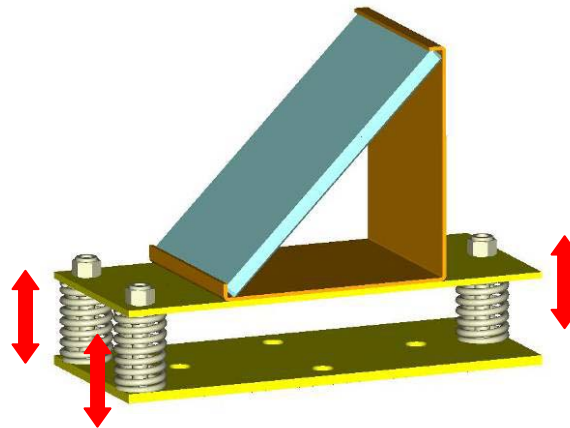

**Fig. 12**

### Mounting sequence

1. Fix the plate to the support, ensuring that it is very stable.

The plate must be mounted respecting the following criteria (Fig. 13):

- Ensure that the active unit is mounted in the definitive position.
- Establish a reference in common with the active unit and mirrors (e.g. floor).
- Measure the distance ( $d1$ ) between the lower optics' centre of the active unit and the reference.
- Fix the lower plate guaranteeing that the interaxis found between the two closest slots has a certain distance ( $d2$ ) from the reference equal to the distance previously measured for the inferior optics ( $d1=d2$ ).
- Fix the upper plate ensuring that the distance between the two interaxis found between the two closest slots is equal to 500 mm.

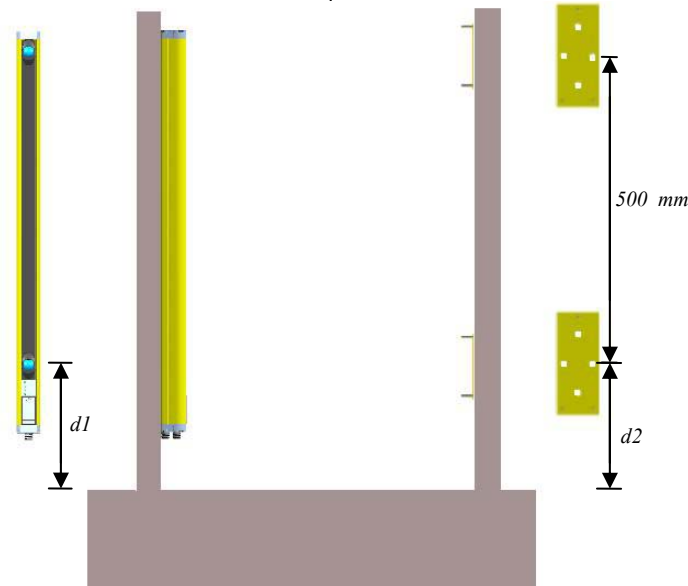

Fig. 13

2. Insert the springs on the plate pins.
3. Insert mirror and support on the pins and block the entire system using the nuts.

Adjust the nuts (screw or unscrew) to increase or decrease the tension on the springs and thus regulate the mirror to obtain the correct orientation.

English

**3.3. Mounting of passive unit**

To mount the active unit use the threaded pins supplied inserting them into the slots on the units (Fig. 14 and Fig. 15).

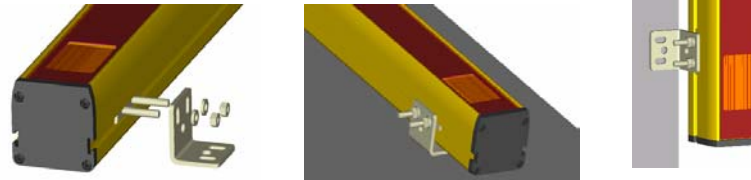

**Fig. 14**

Fixing brackets can be used where no large mechanical compensation is required during the alignment operation. The rotating supports for the correction of the bar inclination are available on request (see section 12 “Accessories”). In case of applications with particularly strong vibrations, anti-vibration shock absorbers, together with threaded pins, rigid brackets and/or rotating supports, are recommended to reduce the impact of the vibrations. Fig. 15 shows the recommended mounting positions according to the safety light curtain length.

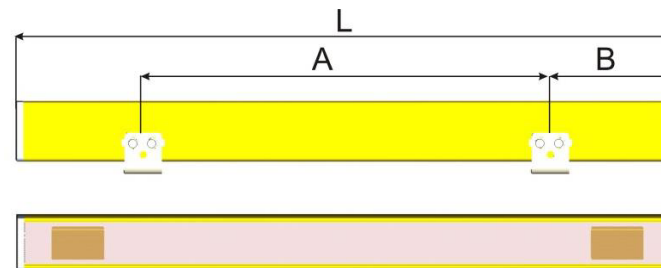

**Fig. 15**

MODEL	L (mm)	A (mm)	B (mm)
SE4-RDB	612	376	118
SE4-RDBL	612	376	118
SE4-RDBT	612	376	118

*Mounting sequence*

- Fix the plate to the support according to the following criteria (Fig. 16).
- Ensure that the active unit is mounted in the definitive position.
- Establish a reference in common with the active unit and mirrors (e.g. floor) and position the units with the **SAFEasy™** labels on the same side.
- Measure the distance ( $d1$ ) between the lower optics' centre of the active unit and the reference.
- Fix the passive part guaranteeing that centre of the profile's front ( $d2$ , please refer to profile's reference mark) is equal to the distance previously measured for the inferior optics of the active unit ( $d1=d2$ ).

English

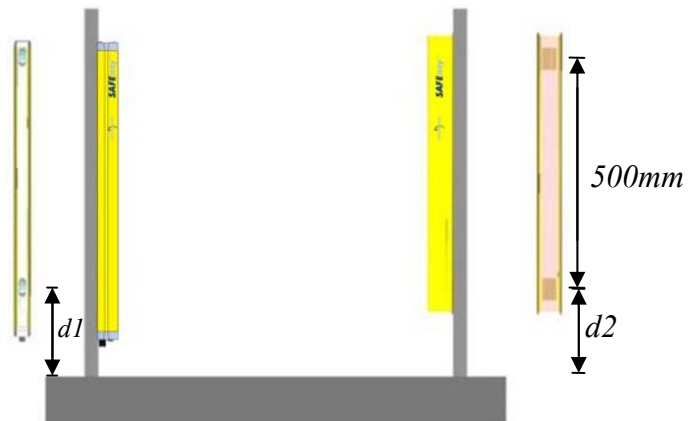

Fig. 16

### 3.4. Mounting of mechanical arms

To mount the arms for the Muting function for both the "L" and "T" version use the fixing brackets provided respectively for the active and passive units (Fig. 18).

This accessory guarantees the perfect arm alignment and ortogonality of these respect to the principal unit.

Position the fixing bracket with the arm (s) mounted on the main unit as shown (Fig. 17).

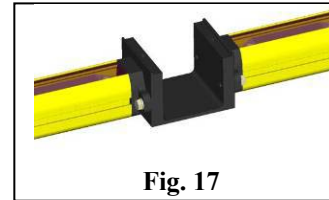

Fig. 17

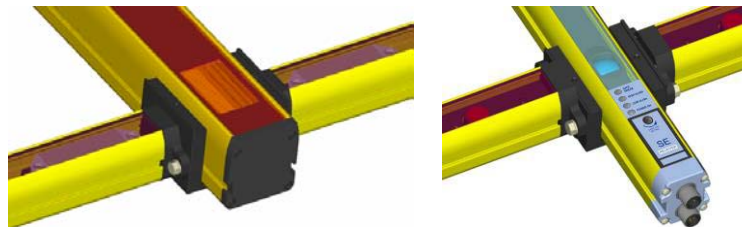

Fig. 18

Verify the correct functioning position and block the group fixing the two plates and screws using a CH.2.5 allen key.

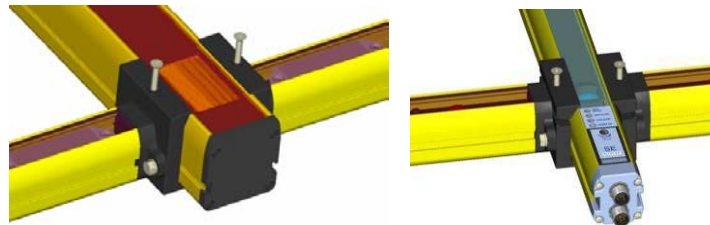

Fig. 19



The following conditions have to be considered when mounting the mechanical arms for the "L" and "T" Muting function:

- Mount the arm with the active Muting sensors on the active unit and the arms with the reflector on the passive unit.
- In the L configuration mount the arms in order to intercept the object before entering in the controlled area.

- The two arms have to be mounted the most parallel and aligned possible. The sensors are alligned by default, but the rotation around the main arm axis can be adjusted by moving the fixing bracket mounted on the profile.
- In difficult applications with strong shocks and vibrations, the arms have to be fixed on the rigid support using the fixing brackets supplied.
- The use of the arms for the Muting function limits the operating distance to maximum 3 m.
- The Muting arms can be adjusted vertically to suit the application and the connection cable length (max. 14 cm height variation allowed).

**English**

### 4. ELECTRICAL CONNECTIONS

All electrical connections are made through M12 male connectors, located on the lower part of the safety light curtain. In particular a M12 8-pole and a M12 5-pole connectors are used for the Muting sensor connection.

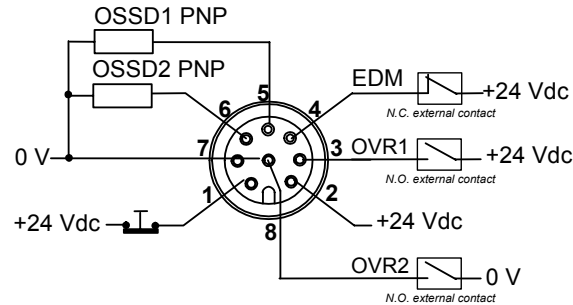

- |            |              |
|------------|--------------|
| 1 = white  | = TEST/START |
| 2 = brown  | = +24 Vdc    |
| 3 = green  | = OVERRIDE1  |
| 4 = yellow | = EDM        |
| 5 = gris   | = OSSD1      |
| 6 = pink   | = OSSD2      |
| 7 = blue   | = 0 V        |
| 8 = red    | = OVERRIDE2  |

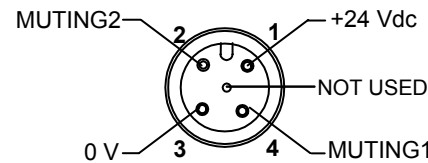

- |           |            |
|-----------|------------|
| 1 = brown | = +24 Vdc  |
| 2 = white | = MUTING2  |
| 3 = blue  | = 0 V      |
| 4 = black | = MUTING1  |
| 5 = grey  | = NOT USED |

#### 4.1. Notes on connections

For the correct functioning of the **SAFEasy™** safety light curtains of the SE4-R Series, the following precautions regarding the electrical connections have to be respected:



- Only shielded cables must be used for the connection of the two units. The light curtain has been developed to offer an adequate immunity level against disturbances in the most critical working conditions.
- It is possible to connect to ground the device housing using the mechanical part supplied for ground connection (refer to configuration illustrated in Fig. 20).

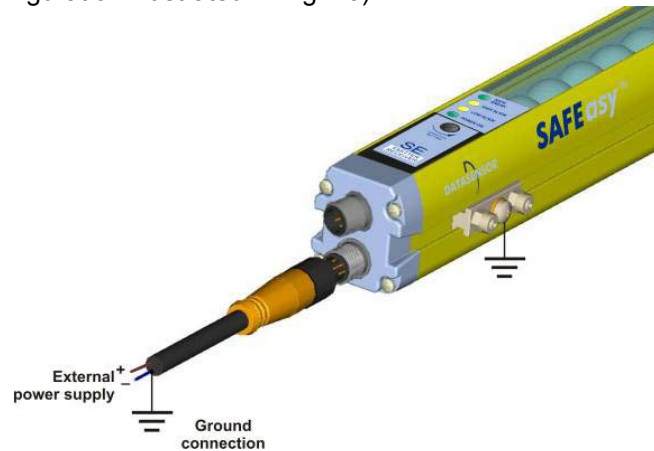



Fig. 20

- Do not place connection cables in contact or near high-voltage cables (e.g. motor power supplies, inverters, etc.);
- Do not connect in the same multi-pole cable the OSSD wires of different light curtains;
- The TEST/START wire must be connected through a N.C. button to the supply voltage of the ESPE. A daily manual test is necessary to verify the correct functioning of the safety light curtain. Push the specific button to activate the test.
- If the light curtain is activated without connecting to 24 Vdc the TEST/START wire, it enters into a monitoring status where the OSSD outputs are not active. Reconnect correctly and restart the system in order to return to normal safety functioning.

-  The TEST/START button must be located in such a way that the operator can check the protected area during any Test, Override and Reset operation. (see section 6 “Functioning mode”).
- The EDM wire has to be connected to a 24 Vdc normally closed contact, before powering.
- The monitoring function, if selected, is not activated if at powering the wire is not correctly connected; in this case the light curtain enters in a failure condition.
- The Muting function is activated only if the wires are connected to the sensors. The integrated Muting lamp is commanded.
-  The device is already equipped with internal overvoltage and overcurrent suppression devices. The use of other external components is allowed but not recommended.
- Read the “Functioning mode” section 6 relative to the Muting function, its use and the positioning of the activating sensors.

The ground connection of the active unit depends on the electrical protection class to be guaranteed (see section 9 "Technical Data" for more information).

This connection can be carried-out using the mechanical part supplied for ground connection (see Fig. 21).

Insert the support plate (M4x0.7 mm threaded holes) in one of the two slots visible laterally on the profile.

The two pins (M4x14) have to be screwed on the external support hole, leaving the central hole free. We suggest to screw the pins using a Couple included between 2.2 and 2.5 Nm.

The Couple guarantees that the pin head passes through the paint allowing the contact with the metal housing.

Block the pins using the two M4 self-fixing nuts.

The nuts have to be tightened using a hexagonal CH.7 wrench.



The nuts avoid the unscrewing of the pins in presence of strong vibrations.

Insert the M4 ring and screw it on the central support hole.



Fig. 21

English

- 
 • The OSSD1 and OSSD2 safety contacts cannot be connected in series or in parallel, but can be used separately (Fig. 22).  
 If one of these configurations is erroneously used, the device enters into the output failure condition (see cap.7 “Diagnostic functions”).
  - Connect both OSSD to the activating device.
- 
 The avoided connection of an OSSD to the activating device jeopardises the system safety degree that the light curtain has to control.

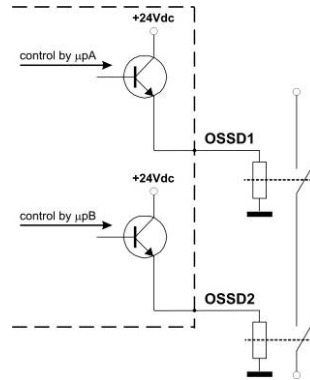

Fig. 22

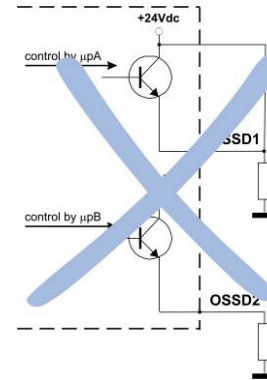

Fig. 23

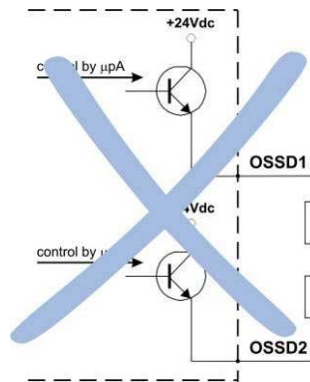

Fig. 24

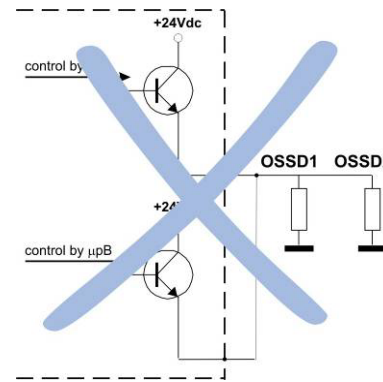

Fig. 25

## 5. ALIGNMENT PROCEDURE

The alignment between the active and passive units is necessary to guarantee the correct device functioning.

### 5.1. Correct light curtain alignment procedure of single mirrors

The light curtain alignment can be effected, only after having completed the mechanical installation and the electrical connections. The following procedure has to be followed:

- Control that the green LED on the active unit is ON (POWER ON).
- Verify that at least one of the following conditions is present:
  - 1 Low green POWER ON LED and high red SAFE/BREAK LED (BREAK) are both ON: non-alignment condition.
  - 2 Low green POWER ON LED and high green SAFE/BREAK LED (SAFE) are both ON: alignment condition.
- Continue with the following steps to pass from condition 1 to condition 2:
  - A The use of a laser pointer, available as an accessory, is recommended, to correctly carry-out the alignment of the two units (see cap 12 “Accessories”).
  - B Fix the mirror-support plates on the vertical bar/wall at the necessary height (see paragraph 3.1).
  - C Position the laser pointer in correspondence of the emitting optic group.
  - D Adjust the mirror placed on the front of the emitting optic group, by simply regulating the screws, in order to guarantee that the spot emitted by the laser pointer centers mirror the most possible.

**NOTE: a reflecting target can be very useful to test the exact spot position.**

- Repeat the same procedure on the mirror placed in front of the receiving optics.
- Always regulating the screws positioned on the front of the receiving optics, verify that the laser spot hits exactly the optics' center.

The system may not result correctly aligned even if these procedures have been carried-out as the laser pointer and emitting optics may not be aligned.

The procedure can be completed by simply adjusting the screws using also the SAFE/BREAK LED signal. The device is correctly configured when the SAFE/BREAK LED becomes green (from red).

**Note:** Ensure that the green light of the SAFE/BREAK LED (as well as the alignment LEDs) is ON and steady.

- Fix the two units firmly using pins and brackets.
- Verify that the green SAFE/BREAK LED is ON on the active unit (condition where the beams are free, SAFE) and verify that the same LED turns red if even one single beam is obscured (condition where an object has been detected, BREAK).

#### 5.2. Guide to correct alignment procedure of passive unit

The light curtain alignment can be effected, only after having completed the mechanical installation and the electrical connections. The following procedure has to be followed:

- Control that the green LED on the active unit is ON (POWER ON).
- Verify that at least one of the following conditions is present:
  - 1 Low green POWER ON LED and high red SAFE/BREAK LED (BREAK) are both ON: non-alignment condition.
  - 2 Low green POWER ON LED and high green SAFE/BREAK LED (SAFE) are both ON: alignment condition.
- Continue with the following steps to pass from condition 1 to condition 2:
  - A The use of a laser pointer, available as an accessory, is recommended, to correctly carry-out the alignment of the two units (see cap 12 “Accessories”).
  - B Fix the mirror-support plates on the vertical bar/wall at the necessary height (see paragraph 3.1).

- C Position the laser pointer in correspondence of the emitting optic group.
- D Adjust the mirror placed on the front of the emitting optic group, by simply regulating the screws, in order to guarantee that the spot emitted by the laser pointer centers mirror the most possible.

**NOTE:** a reflecting target can be very useful to test the exact spot position.

**Verify that the laser spot hits exactly the optics' center by regulating the screws positioned on the front of the receiving optics.**

The system may not result correctly aligned even if these procedures have been carried-out as the laser pointer and emitting optics may not be aligned.

The device is correctly configured when the SAFE/BREAK LED becomes green (from red).

**NOTE:** Ensure that the green light of the SAFE/BREAK LED (as well as the alignment LEDs) is ON and steady.

- Fix the two units firmly using pins and brackets.
- Verify that the green SAFE/BREAK LED is ON (condition where the beams are free, SAFE) and verify that the same LED turns red if even one single beam is obscured (condition where an object has been detected, BREAK).

English

•

### 5.3. Guide to correct alignment procedure of Muting arms

The correct aligned of the arm's Muting sensors has to be verified by adjusting the specific fixing racket, after having aligned the safety light curtain, mounted the arms and electrical connection.

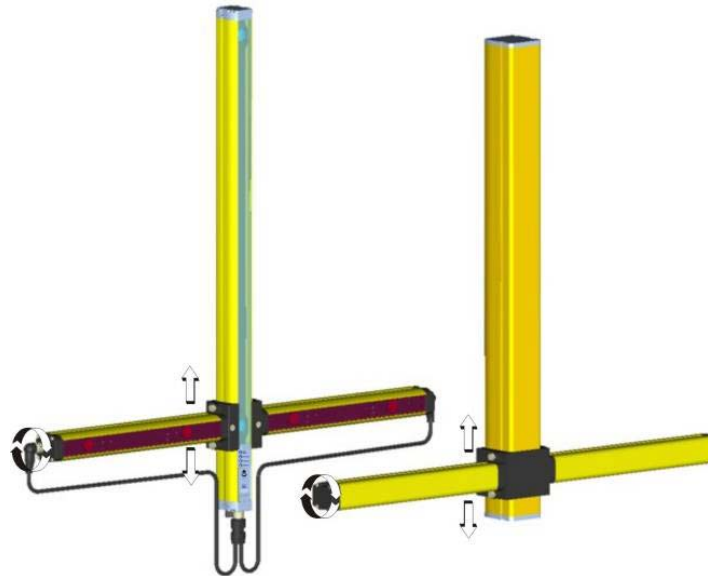

Fig. 26

The arm height can be changed according to the position height and rotation respect to the main axis.

Avoid precarious alignment conditions controlling carefully the status of the signalling LEDs positioned on the active arms.

The optimal alignment condition is reached when all signalling LEDs are off.

## 6. FUNCTIONING MODE

### 6.1. Dip-switch selectable functions

A slot situated in the front side of the active unit (Fig. 27), that can be easily opened using a screwdriver, facilitates the access to the internal dip-switches for the configuration of the following functions:

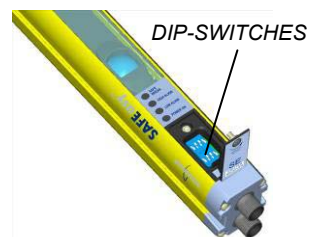
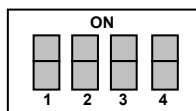

Fig. 27

dip-sw	Function	ON	OFF
1	Muting time-out	10 min.	$\infty$
2	Muting	4 beam config.	2 beam config.
3	EDM	Deactivated	Activated
4	Reset	Automatic	Manual

**⚠ Muting time-out “ $\infty$ ” does not comply with the requirements of IEC 61496-1. Therefore all possible risks must be considered and related precautions undertaken before selecting the “ $\infty$ ” option.**

**⚠** The device does not accept configuration changes during normal functioning. A change is accepted only beginning from the successive powering of the device. Particular attention has to be taken during the configuration dip-switch management and use.

**👉 Note:** For the SE4-R devices, the top and bottom dip-switches must be configured in the same manner.

### 6.2. Standard configuration

The device is supplied with the following standard configuration with all dip-switches ON, i.e.:

Muting time-out = 10 min	EDM deactivated
4 beam Muting configuration	Automatic Reset

**Note:** The Muting function can be activated only if the Muting1 and Muting2 inputs are correctly connected. The EDM function can be activated only if the specific input is correctly connected to the appropriate device. For further details of these functions see sections 6.3 and 6.4.

**6.3. Restart mode**

The interruption of the infrared beams due to an opaque causes the switching of the OSSD outputs (i.e. the opening of the safety contacts - BREAK condition).

The restart of the ESPE (i.e. the closing of the OSSD safety contacts - SAFE condition) can be carried-out in two different ways:

**Automatic Restart:** when an opaque object is detected, the ESPE enters in the BREAK condition. Then, after the opaque object has been removed from the controlled area, the ESPE begins its normal functioning again.

**Manual Restart:** after the ESPE has detected an opaque object in the controlled area, the light curtain begins its normal functioning again only by pressing the Restart button (press TEST/START button for at least 0.5sec) and after the object has been removed from the controlled area.

*Temporal diagram (Manual Restart)*

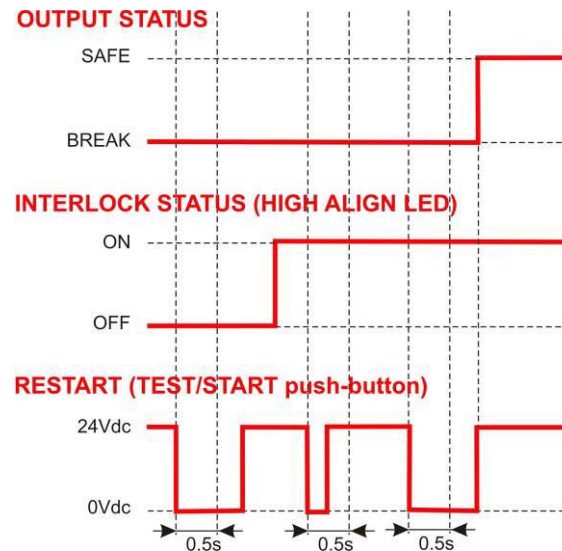
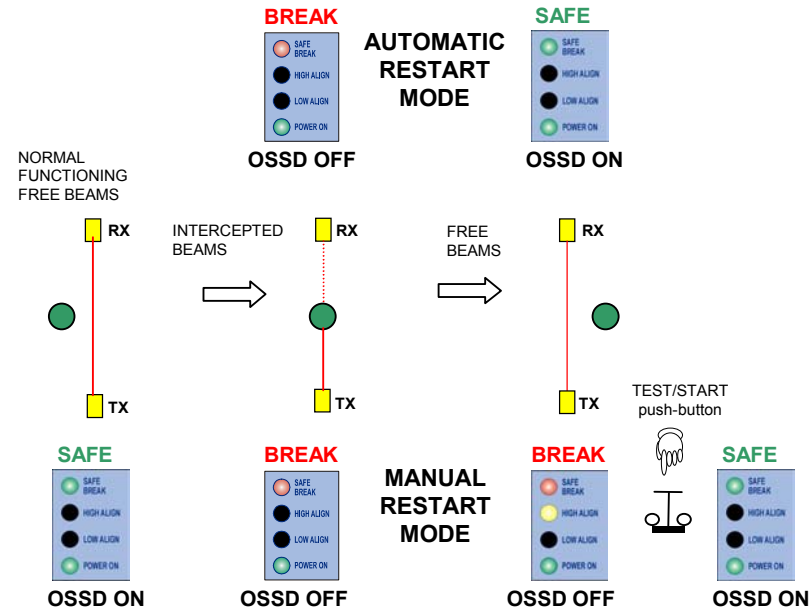

Fig. 28 below shows the two functioning modes.



English

Fig. 28

The selection of the manual/automatic Restart mode is made using the dip-switches placed under the slot of the active unit. In particular, the position 4 of both switches must be ON to activate the automatic Restart mode; OFF for the manual Restart mode.

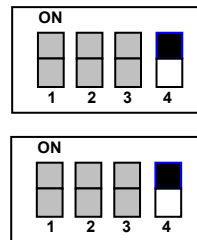

**Note:** The dip-switches not used for this function are in grey. The lever position of the specific dip-switch is in black (ON) in the automatic Restart mode.

#### 6.4. Reset function

The light curtain has a Reset function that is activated in presence of an internal failure.

The operator has to press the TEST/START button resetting the break condition and thus return to normal functioning.

The button has to be kept pressed for at least 5 seconds in one of the following conditions:

- *output failure;*
- *optic failure;*
- *failure of the Muting signalling device;*
- *failure of EDM test function.*

#### Temporal diagram of the Reset function

##### Safety light curtain status

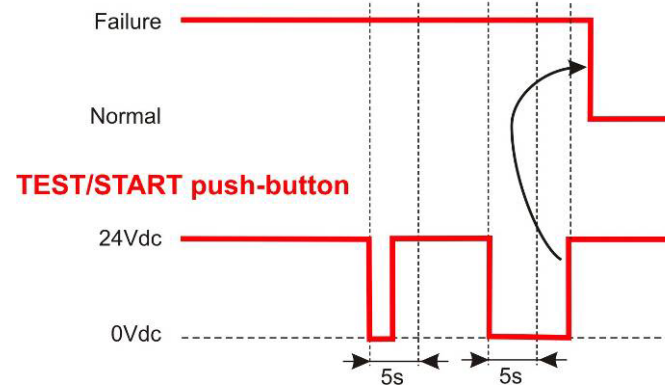

### 6.5. Muting function

The Muting sensors must be able to recognise the passing material (pallets, vehicles, ...) according to the material's length and speed.

In case of different transport speeds in the Muting area, it is necessary to consider their effect on the total Muting duration.

- The Muting function, excludes the light curtain during functioning, maintaining active the OSSD outputs, according to particular operating requirements (Fig. 29).

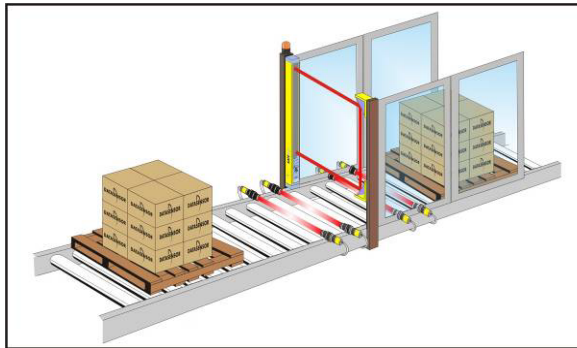

Fig. 29

- The safety light curtain is equipped with two inputs (Muting1 and Muting2) for the activation of this function, according to the Standards in force.
- This function is particularly suitable when an object, but not a person, has to pass through the dangerous area, under certain conditions.
- It is important to remember that the Muting function represents a forced system condition and therefore has to be used with the necessary precautions.



English

Two Muting sensors activate the two inputs. These two sensors have to be correctly connected and positioned in order to avoid undesired Muting or potentially dangerous conditions for the operator.

The Muting status is signalled by the Muting lamp built-in the active unit.



The Muting lamp has to be visibly and clearly positioned during installation.

If the Muting lamp is faulty, the Muting or Override opens the safety contacts and signals the Muting lamp failure status and the device is blocked (refer to *cap.7.4 "Fault and diagnostic messages"*).



Fig. 30 shows an example of Muting functioning:

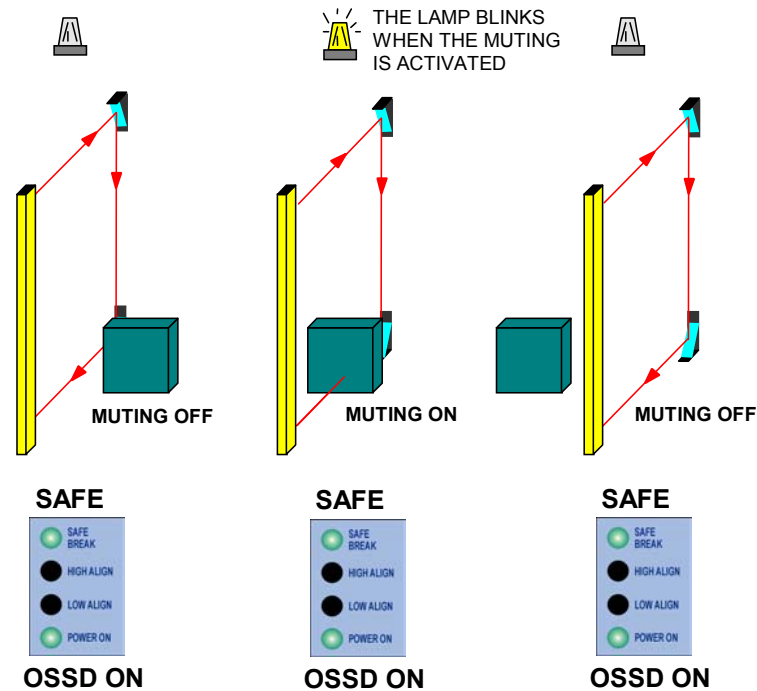
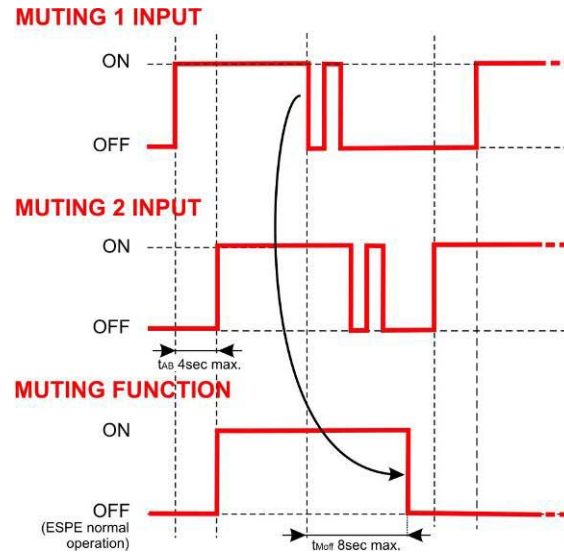

Fig. 30

Temporal diagram of the Muting function for two-sensor configuration (crossed-beam version)



English

Temporal diagram of the Muting function for four-sensor configuration

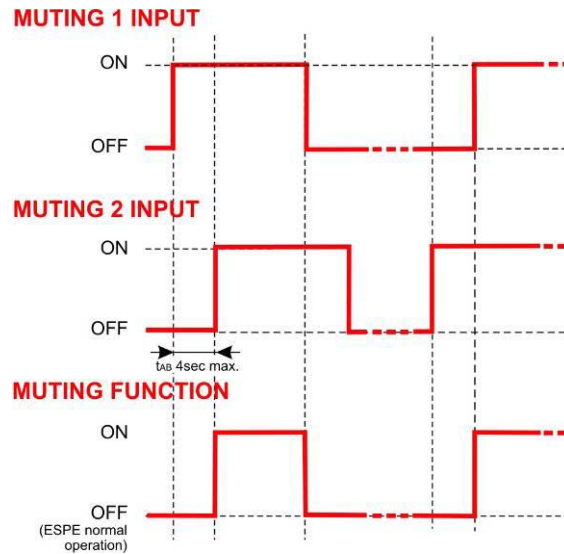

### 6.6. Muting function

 The safety light curtains of the SE4-R Series have a dip-switch dedicated to the Muting configuration selection.

The requested configuration is obtained using the dip-switches n° 2 present on the receiving unit.

With dip-switch 2 ON, the 4-sensor configuration is obtained.

With dip-switch 2 OFF, the 2-sensor configuration is obtained.

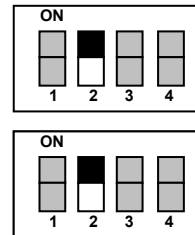

 **Select carefully the configuration, as a wrong configuration can cause the incorrect functioning of the Muting function and a reduction of the safety level.**

- The Muting sensors must be positioned in such a way that the activation of the Muting function is not possible with the accidental passing of a person.
- The Muting request can be performed in 2 manners:
  - activating the two Muting inputs contemporarily;
  - activating the Muting1 first and then the Muting2, or viceversa.

If the activations occur in sequence, the second activation should occur within 4 sec. after the first; otherwise the Muting will not be activated.

Any Muting request can not be made if the ESPE is in the BREAK condition (red LED is ON and the beams are interrupted).

### 6.6.1. Applications

Fig. 31 provides an installation example of a SE4-R light curtain mounted on a conveyor, with the relative external Muting sensors. The A1, A2, B1, B2 Muting activation sensors temporarily inhibit the ESPE if a package passes between the sensors. The outputs of these sensors are connected to the Muting1 and Muting2 inputs of the receiving unit of the ESPE. The contacts of these sensors are controlled by the active unit.

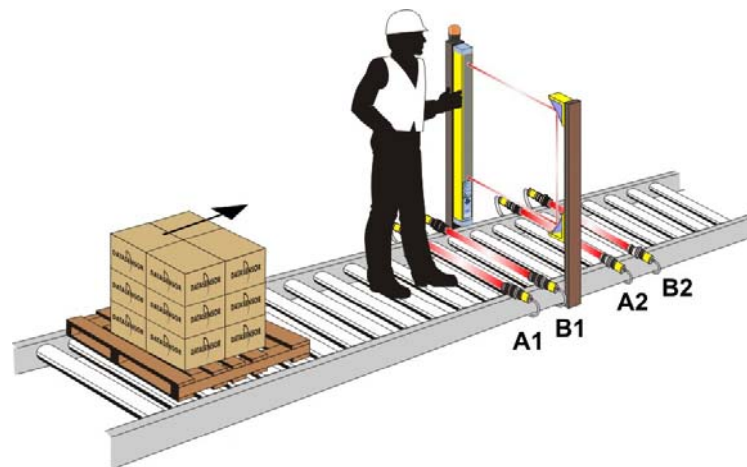

Fig. 31

English

Optoelectronic, mechanical, proximity sensors etc, can be used as Muting sensors, with closed contact in the presence of the object to be detected.

The following are some configuration examples when using the Muting function:

**- Application with 4 optoelectronic sensors: parallel-beam configuration**

The solution is suitable for applications requiring bidirectional movements of objects.

For correct functioning, position the dip-switches 2 in the ON position.

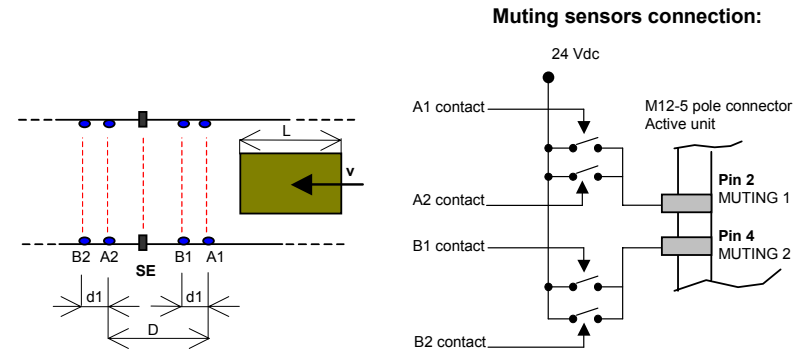

Symbol	Unit	Formula	Min	Typ	Max	Description
D	cm		L			Interaxis between sensors connected to the same Muting input
d <sub>1</sub>	cm	$= V * t_{AB} * 100$	0.1			Interaxis between sensor A and sensor B
t <sub>AB</sub>	sec	<b>Compulsory condition</b>	0.01		4	Activation time of the second sensor after first sensor activation (A→B) (B→A)
D <sub>oA</sub>	cm		d <sub>1</sub> + D			Distance to respect between adjacent objects to obtain the correct Muting functioning
L	cm		D			Object dimension to activate the Muting function passing between the sensors
V	cm/sec	$= d_1 / t_{AB}$			250 (suggested)	Object speed to activate the Muting function passing between the sensors

### - Application with 2 optoelectronic sensors: parallel-beam configuration

The solution is suitable for applications requiring unidirectional movements of objects.

For correct functioning, position the dip-switch 2 in the OFF position.

The reset of normal Muting functioning is obtained at a DMoff distance from sensor A.

#### Muting sensors connection:

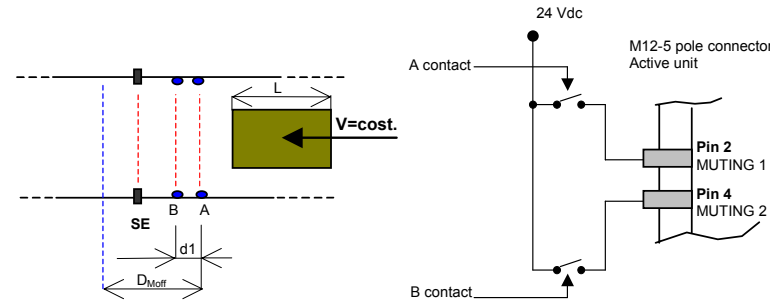

English

Symbol	Unit	Formula	Min	Typ	Max	Description
$d_1$	cm	$= V * t_{AB} * 100$	0.1			Interaxis between sensor A and sensor B
$D_{Moff}$	cm	<b>Compulsory condition</b>		33		Distance from sensor A at which the Muting function is deactivated and the light curtain returns to normal functioning
$t_{AB}$	sec	<b>Compulsory condition</b>	0.01		4	Activation time of the second sensor after first sensor activation (A→B)
$t_{Moff}$	sec	$= D_{Moff} / V$		0.132 <i>(at max. suggested speed)</i>	8	Time period, referred to sensor A, after which the Muting function is deactivated and the light curtain returns to normal functioning
$D_{oA}$	cm	$= D_{Moff}$	33			Distance to respect between adjacent objects to obtain the correct Muting functioning
$L$	cm		$d_1$			Object dimension to activate the Muting function passing between the sensors
$V$	cm/sec	$= d_1 / t_{AB}$	4.125		250 <i>recommended</i>	Object speed to activate the Muting function passing between the sensors

6.6.2. SE4-RA1-L model

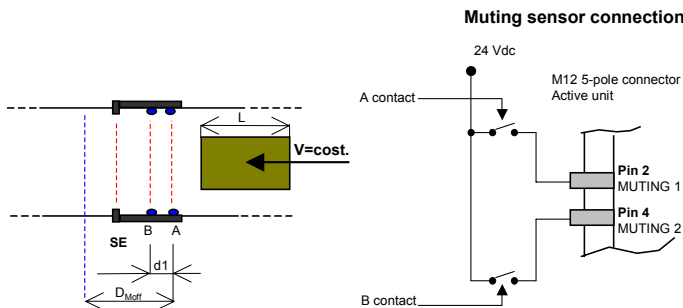

The Muting solution integrated in the “L” configuration facilitates sensor installation and suits applications with only one object entrance direction.

For correct functioning, put dip-switch 2 in the OFF position.

The re-activation of normal functioning of the Muting condition is obtained at a  $D_{Moff}$  distance from sensor A.

Simble	Unit	Formula	Min	Typ	Max	Description
$d_1$	cm	<b>Compulsory condition</b>		16.5		Interaxis between sensor A and sensor B
$D_{Moff}$	cm	<b>Compulsory condition</b>		33		Distance from sensor A at which the Muting function is deactivated and the light curtain returns to normal functioning
$t_{AB}$	sec	<b>Compulsory condition</b>	0.01		4	Activation time of the second sensor after first sensor activation (A→B)
$t_{Moff}$	sec	$= D_{Moff} / V$	0.132 <i>(at max. recommended speed)</i>		8	Time period, referred to sensor A, after which the Muting function is deactivated and the light curtain returns to normal functioning
$D_{OA}$	cm	$= D_{Moff}$	33			Distance to respect between adjacent objects to obtain the correct Muting functioning
L	cm		$d_1$			Object dimension to activate the Muting function passing between the sensors
V	cm/sec	$= d_1 / t_{AB}$	4.125		250 <i>(reccomended)</i>	Object speed to activate the Muting function passing between the sensors

## 6.6.3. SE4-RA1-T model

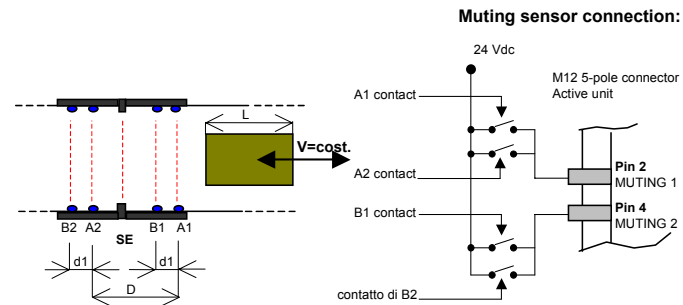

The Muting solution integrated in the “T” configuration facilitates sensor installation and suits applications with a two-way object direction.

For correct functioning, put dip-switch 2 in the ON position.

The re-activation of normal functioning of the Muting condition is obtained deactivating A2 (or B1 according to the object entrance direction).

Simble	Unit	Formula	Min	Typ e	Max	Description
D	cm	<b>Compulsory condition</b>		34.5		Interaxis between sensors at the same Muting entrance
d <sub>1</sub>	cm	<b>Compulsory condition</b>		16.5		Interaxis between sensor A and sensor B
t <sub>AB</sub>	sec	<b>Compulsory condition</b>	0.01		4	Activation time of the second sensor after first sensor activation (A1→B1) (B2→A2)
t <sub>Moff</sub>	sec	= D <sub>Moff</sub> / V	0.132 <i>(at max. recommended speed)</i>		8	Time period, referred to sensor A2 (B1), after which the Muting function is deactivated and the light curtain returns to normal functioning
D <sub>OA</sub>	cm		d <sub>1</sub> + D = 51			Distance to respect between adjacent objects to obtain the correct Muting functioning
L	cm	= D	34.5			Object dimension to activate the Muting function passing between the sensors
v	cm/sec	= d <sub>1</sub> / t <sub>AB</sub>	4.125		250 <i>(recommended)</i>	Object speed to activate the Muting function passing between the sensors

English

### 6.7. Override function

This function allows to force a Muting condition when machine reset is necessary, even if one or more beams are interrupted by passing material.

The purpose is to clear the protected area of any material accumulated consequently to a failure in the working cycle.

For example, if a pallet stops inside the protected area, the conveyor may not restart as the ESPE (that has one or more interrupted beams) opens the OSSD outputs and will not permit the controlled area clearance.

The activation of the Override function makes permits this operation.

#### - **Activation of the Override function**

The activation of the Override function can not be made from a block condition.

When the activation request is coherent, the user interface signals that the Override function can be carried-out.

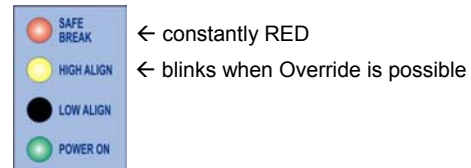

Two input lines are available to activate the Override function (OVR1 and OVR2) that have to be connected respectively to 24 Vdc and to 0 Vdc through normally open contacts.

Usually an automatically resetting key/push-button is used to activate the function. The key/push-button is positioned outside the dangerous area.

The Override function is activated closing both contacts contemporarily.

A maximum 400 ms de-synchronisation period between the closing of the two contacts is present as shown below.

Temporal diagram of the Override function

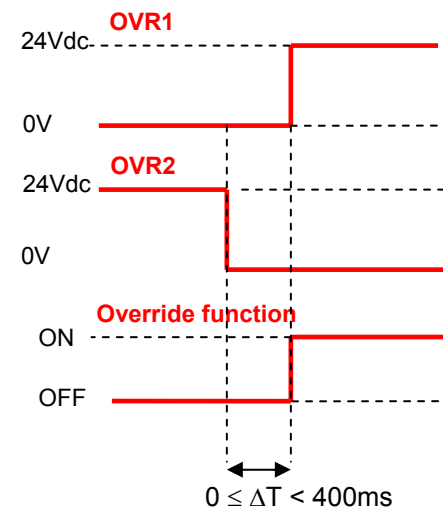

English

The Override function ends automatically when one of the following conditions occurs:

- all Muting sensors are active (\*);
- when Muting time-out is overdue;
- the necessary conditions for the function activation are no longer present (at least one Override input is deactivated).

*(\*) this occurs for the safety light curtains with T-Muting configuration. In safety light curtains with L-Muting configuration, the Override function will end when the Muting sensors are deactivated and the light curtain enters in the free beam condition.*

- Turn the key/push-button ON until the protected area is free.
- When the Override function is activated, the external Muting signalling lamp blinks to indicate that the safety device has been excluded.
- The maximum duration of the Override function is 120 seconds. After that time the ESPE returns to normal functioning, even if the the Override contacts are kept closed.  
If the key/push-button is released before the maximum time, the Override function is immediately interrupted.

All possible error conditions during functioning as explained in the following table:

Error	Cause	Action
Contacts not closed simultaneously: When the Override function is tested, the activation time-out ends.	A short-circuit at Vdc or GND may be present in one of the two Override inputs or the contacts may be faulty.	Override is deactivated; error signalled through LED user interface. This is not a block condition and so the Override function can be activated as soon as the error has been solved.

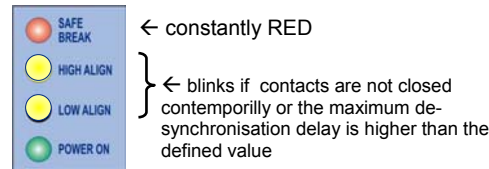

### 6.8. EDM function

The External Devices Monitoring (EDM) function carries-out the light barrier control by opening/closing the electrical contacts.

To correctly use this function:

- select it using the specific dip-switch
- connect EDM input to the 24Vdc N.C. contact of the device to control.

The function controls the N.C. contact switching according to the changes of the OSSD status.

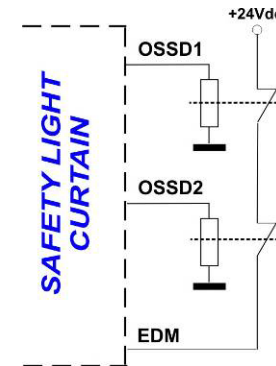

#### OSSD STATUS

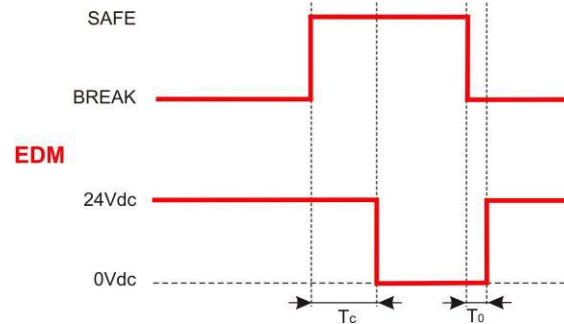

$T_c \geq 350\text{msec}$  time after the OSSD OFF-ON passage when EDM is carried-out

$T_0 \geq 100\text{msec}$  time after the OSSD ON-OFF passage when EDM is carried-out

The use of non-conform devices may cause failures.

The periodical testing of the function is recommended.

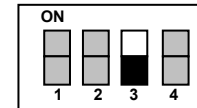

**The correct dip-switch positioning (dip 3 OFF) for the function activation is shown here aside.**

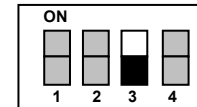

English

## 7. DIAGNOSTIC FUNCTIONS

### 7.1. Visualisation of the functions

The operator can visualise the operating condition of the light curtains through four LEDs positioned on the active unit (Fig. 32).



Fig. 32

The meaning of the LEDs positioned on the active unit depends on the light curtain operating mode.

## 7.2. Alignment control

In this condition the outputs are OFF.

### SAFE LED (Safe/Break) GREEN/RED:

**GREEN ON (Safe):** indicates that the active and passive units are aligned and no objects have been detected.

**RED ON (Break):** indicates that the two RX and TX units are non-aligned or an object has been detected.

### POWER ON LED (Power) GREEN:

**GREEN ON** indicates that the unit is correctly aligned.

## 7.3. Operating mode

### SAFE LED (Safe/Break) GREEN/RED:

**GREEN ON (Safe):** indicates that no objects have been detected.

**RED ON (Break):** indicates that an object has been detected. In this condition the outputs are OFF.

### HIGH ALIGN LED (Interlock) YELLOW:





























**FIXED ON:** signals the need to press TEST/START to re-start the device, after object detection.









This situation occurs only when the device is configured in the manual Reset mode.

7.4. Fault and diagnostic messages

The operator is able to check the main causes of the system stop and failure, using the same LEDs used for the visualisation of the functions.

**ACTIVE UNIT:**

Failure	Cause	Check and repair
 SAFE BREAK  HIGH ALIGN  LOW ALIGN  POWER ON Red blinking Yellow blinking Green ON	Output failure	<ul style="list-style-type: none"> <li>- Check the output connections.</li> <li>- Check if the load characteristics are in accordance with the Technical data (<i>see section 9</i>)</li> </ul>
 SAFE BREAK  HIGH ALIGN  LOW ALIGN  POWER ON Red blinking OFF Yellow blinking Green ON	Failure of external switching device (EDM test function)	<ul style="list-style-type: none"> <li>- Control the EDM connections</li> <li>- Check the compatibility of external switching device with EDM test time</li> <li>- Switch OFF and switch ON the devices; if failure persists replace external switching device</li> </ul>
 SAFE BREAK  HIGH ALIGN  LOW ALIGN  POWER ON OFF Yellow blinking Green ON	Microprocessor failure	<ul style="list-style-type: none"> <li>- Check the correct positioning of the configuration dip-switches.</li> <li>- Switch OFF and switch ON the device; if the failure continues contact DATASENSOR</li> </ul>
 SAFE BREAK  HIGH ALIGN  LOW ALIGN  POWER ON Red ON Yellow blinking OFF Green ON	Override request possible	<ul style="list-style-type: none"> <li>- This signal is not an error</li> <li>- Activate Override to remove the material inside the protected area.</li> </ul>
 SAFE BREAK  HIGH ALIGN  LOW ALIGN  POWER ON Red ON Yellow blinking Green ON	Override failure	<ul style="list-style-type: none"> <li>- Control the contacts of the Override function; if the failure continues contact DATASENSOR.</li> </ul>
 SAFE BREAK  HIGH ALIGN  LOW ALIGN  POWER ON OFF OFF Yellow blinking Green ON	Optic failure	<ul style="list-style-type: none"> <li>- Verify the alignment of both units.</li> <li>- Switch OFF and switch ON the device; if the failure continues contact DATASENSOR</li> </ul>
 SAFE BREAK  HIGH ALIGN  LOW ALIGN  POWER ON Green blinking Yellow blinking Green ON	Failure of the external Muting signalling lamp	<ul style="list-style-type: none"> <li>- Switch OFF and switch ON the device; if the failure continues contact DATASENSOR</li> </ul>

Failure	Cause	Check and repair
 OFF  OFF  OFF  OFF	Power supply failure	<ul style="list-style-type: none"> <li>- Check power supply.</li> <li>- If the failure continues contact DATASENSOR</li> </ul>
 OFF  OFF  OFF  Green ON	<p>The power supply voltage is outside the allowed range.</p> <p>Main microprocessor failure</p>	<ul style="list-style-type: none"> <li>- Check power supply.</li> <li>- Switch OFF and switch ON the device; if the failure continues contact DATASENSOR</li> </ul>

## 8. CHECKS AND PERIODICAL MAINTENANCE

The following is a list of recommended check and maintenance operations that should be periodically carried-out by qualified personnel.

Check that:

- The ESPE stays locked during beam interruption along the entire protected area, using the suitable "Test Piece".
- Pressing the TEST/START button, the OSSD outputs should open (the red BREAK LED is ON and the controlled machine stops).
- The response time at the machine STOP (including response time of the ESPE and of the machine) is within the limits defined by the calculation of the safety distance (see section 2 "Installation Mode").
- The safety distance between the dangerous areas and the ESPE are in accordance with the instructions included in section 2 "Installation Mode".
- Access to the dangerous area of the machine from any unprotected area is not possible .
- The ESPE and the external electrical connections are not damaged.

The frequency of checks depends on the particular application and on the operating conditions of the safety light curtain.

### 8.1. Maintenance

The SE4-R safety devices do not require any particular maintenance, with the exception of the cleaning of the protection front surfaces of the optics.

When cleaning, use a cotton cloth dampened with water.



**Do not under any circumstances use:**

- alcohol or solvents
- wool or synthetic cloths

### 8.2. General information and useful data

The safety devices fulfil their safety function only if they are correctly installed, in accordance with the Standards in force.



If you are not certain to have the expertise necessary to install the device in the correct way, DATASENSOR Technical Service is at your disposal to carry-out the installation.

Auto-regenerating type fuses are used. Consequently, in presence of a short-circuit, these fuses protect the device.

After the intervention of the fuses, it is necessary to disconnect the power supply and wait for 20 seconds so that the fuses can automatically restart normal functioning.

A power failure caused by interferences may cause the temporary opening of the outputs, but the safe functioning of the light curtain will not be compromised.

### 8.3. Warranty

All appliances are under a 36 month warranty from the manufacturing date.

DATASENSOR will not be liable for any damages to persons and things caused by the non-observance of the correct installation modes and device use.

The warranty will not cover damages caused by incorrect installation, incorrect use and accidental causes such as bumps or falls.

In presence of a non-functioning device, always return the emitting and receiving units for repair or replacement.



In presence of failures send the both units to DATASENSOR S.p.A.

#### **Sales Technical Service**

Tel.: +39 051 6765611

Fax: +39 051 6759324

email: [service@datasensor.com](mailto:service@datasensor.com)

### 9. TECHNICAL DATA

Power supply = Vdd:	24 Vdc ± 20% (SELV/PELV)
Internal capacitance:	120 nF (Rx)
Active unit consumption:	100 mA max. (without load) / 3W
Outputs:	2 PNP outputs (2 NPN on request) short-circuit protection max: 1.4A at 55°C min: 1.1A at -10°C
Output current:	0.5 A max / each output
Output voltage - ON min:	Vdd -1 V
Output voltage - OFF max:	0.2 V
Leakage current:	< 1mA
Capacitive load (pure):	65 nF max at 24 Vdc
Resistive load (pure):	56Ω min. at 24 Vdc
Response time:	14 msec.
Emission type:	Infrared (880 nm)
Resolution:	515 mm
Operating distance:	0.5...7.5 m ("Linear" version) 0.5...3 m ("T" and "L" versions)
Safety category:	Type 4
Auxiliary functions:	Override Automatic/Manual Reset/EDM/Reset
Time-out period:	Muting: 10 minutes / ∞ Override: 2 minutes
Operating temperature:	- 10...+ 55 °C
Storage temperature:	- 25...+ 70 °C
Temperature class:	T6
Humidity:	15...95 % (no condensation)
Electrical protection:	Class 1 (**refer to note)
Mechanical protection:	IP 65 (EN 60529)
Ambient light rejection:	IEC-61496-2
Vibrations:	0.35 mm width, 10 ... 55 Hz frequency, 20 sweep for each axis, 1octave/min (EN 60068-2-6)
Shock resistance:	16 ms (10 G) 1.000 shock for each axis (EN 60068-2-29)
Reference Standards:	IEC 61496-1; IEC 61496-2
Housing material:	Painted aluminium (yellow RAL 1003)
Cap material:	PC MAKROLON
Lens material:	PMMA
Connections:	M12 8-pole connector + M12-5 pole connector (active unit)
Cable length:	50 m. max (* refer to note) (with 50nF capacitive load and Vdc=24V)
Weight:	1.2 Kg max./m of total height

\* = if a longer cable is used, please verify that the same specifications are respected.

** Electrical protection	Class 1	Class 3
Protective grounding	Compulsory	Not accepted
Symbol for connection protective grounding	Compulsory	Not accepted
Protection by means of extra-low voltage with protective separation (SELV and PELV)	Recommended	Compulsory

### 10. DIMENSIONS

All the dimensions are given in mm.

#### Linear version – Active unit

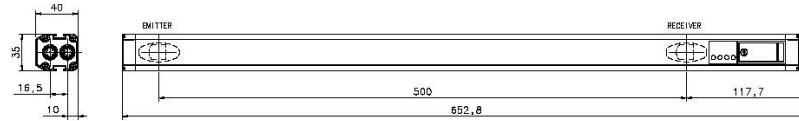

MODEL	DESCRIPTION
SE4-RA1-PP-W	ACTIVE H=500mm PNP-PNP-NO

#### Linear version – Passive unit

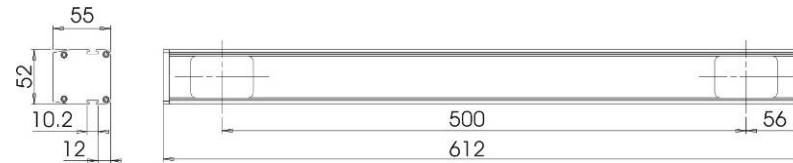

MODEL	DESCRIPTION
SE4-RDB	DEFLECTING BAR H=500

#### Deviating mirror

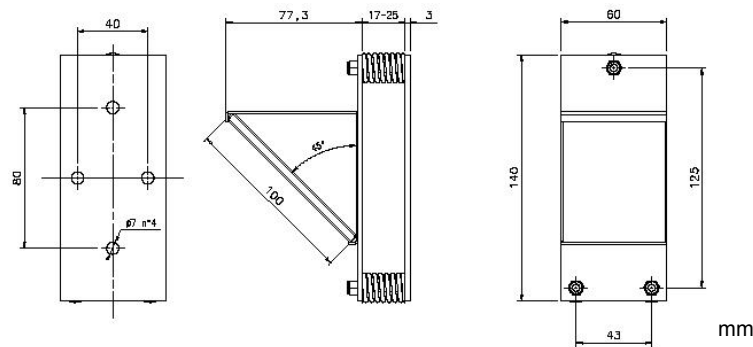

MODEL	DESCRIPTION
SE4-R	Deviating mirror

English

T/L version – Active unit

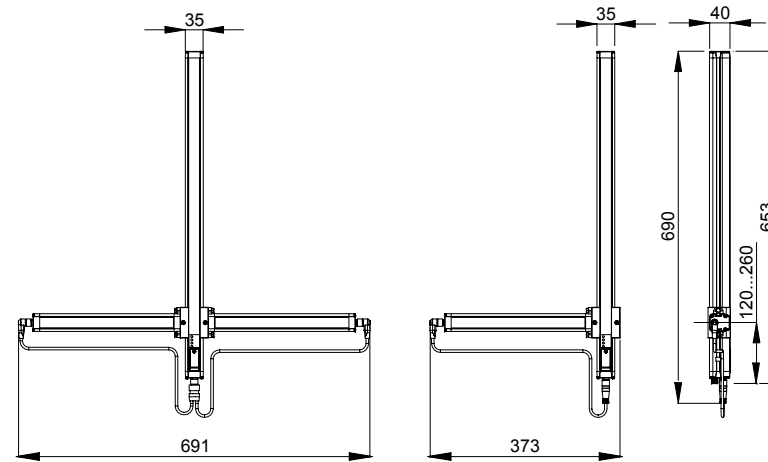

MODEL	DESCRIPTION
SE4-RA1L-PP-W	L-ACTIVE H=500mm PNP-PNP-NO
SE4-RA1T-PP-W	T-ACTIVE H=500mm PNP-PNP-NO

T/L version - Passive unit

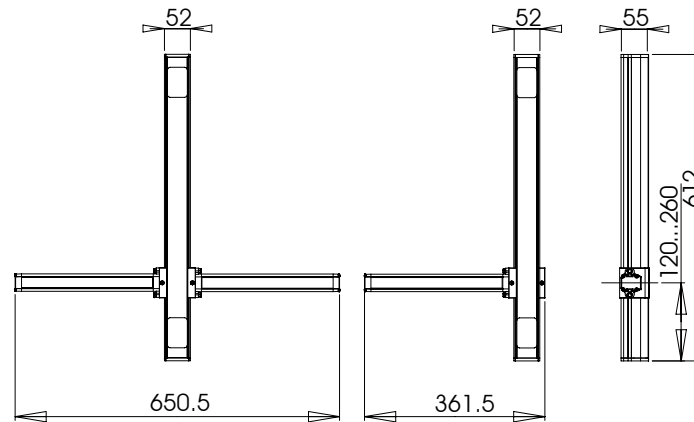

MODEL	DESCRIPTION
SE4-RDBL	L-PASSIVE DEFLECTING BAR H=500
SE4-RDBT	T-PASSIVE DEFLECTING BAR H=500

## 11. ACCESSORIES

### Muting arms for “L” versions

MODELLO	DESCRIZIONE
SE4-RLS	Active “L” arm with integrated Muting sensors
SE4-RLR	Passive “L” arm with integrated reflectors

**SE4-RLS**

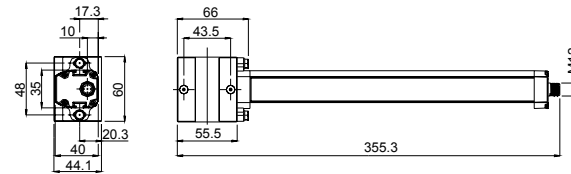

**SE4-RLR**

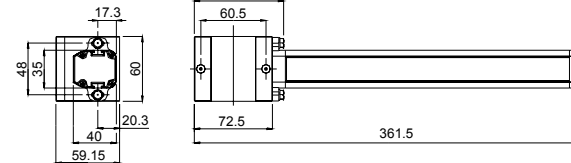

### Muting arms for “T” versions

MODELLO	DESCRIZIONE
SE4-RTS	Active “T” arm with integrated Muting sensors
SE4-RTR	Passive “T” arm with integrated reflectors

**SE4-RTS**

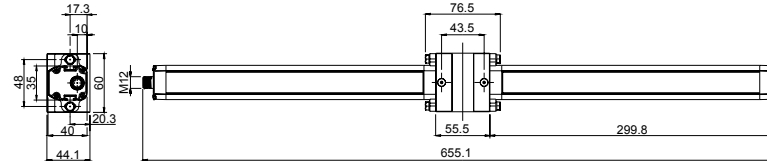

**SE4-RTR**

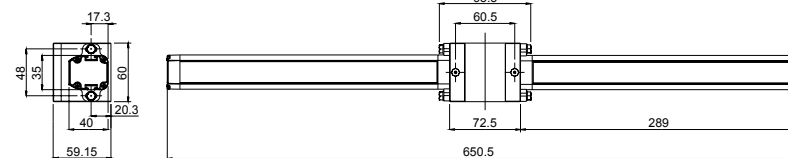

English

Fixing brackets

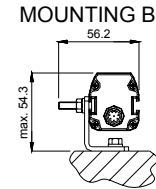
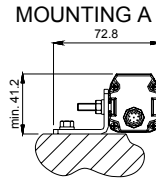

Angled fixing bracket

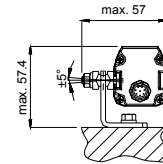
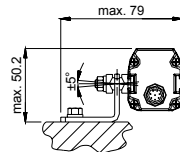

Angled fixing bracket + Orientable support

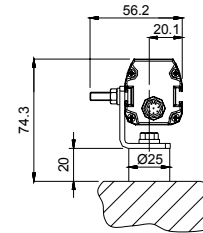
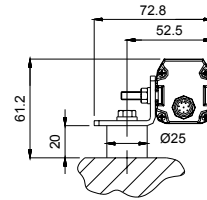

Angled fixing bracket + Antivibration support

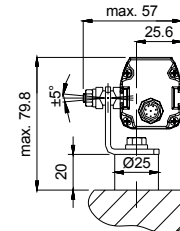
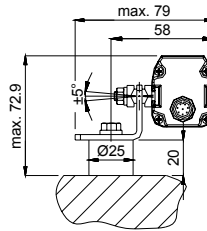

Angled fixing bracket + Orientable support + Antivibration support

MODEL	DESCRIPTION
ST-KSTD	Fixing brackets for angle mounting (4 pcs kit)
ST-K4AV	Antivibration support (4 pcs kit)
ST-K6AV	Antivibration support (6 pcs kit)
ST-K4OR	Orientable support (4 pcs kit)
ST-K6OR	Orientable support (6 pcs kit)

## Columns and floor stands

MODEL	DESCRIPTION	L (mm)	X (mm)
SE-S 800	Column and floor stand H= 800 mm	800	30x30
SE-S 1000	Column and floor stand H= 1000 mm	1000	30x30
SE-S 1200	Column and floor stand H= 1200 mm	1200	30x30
SE-S 1500	Column and floor stand H= 1500 mm	1500	45x45
SE-S 1800	Column and floor stand H= 1800 mm	1800	45x45

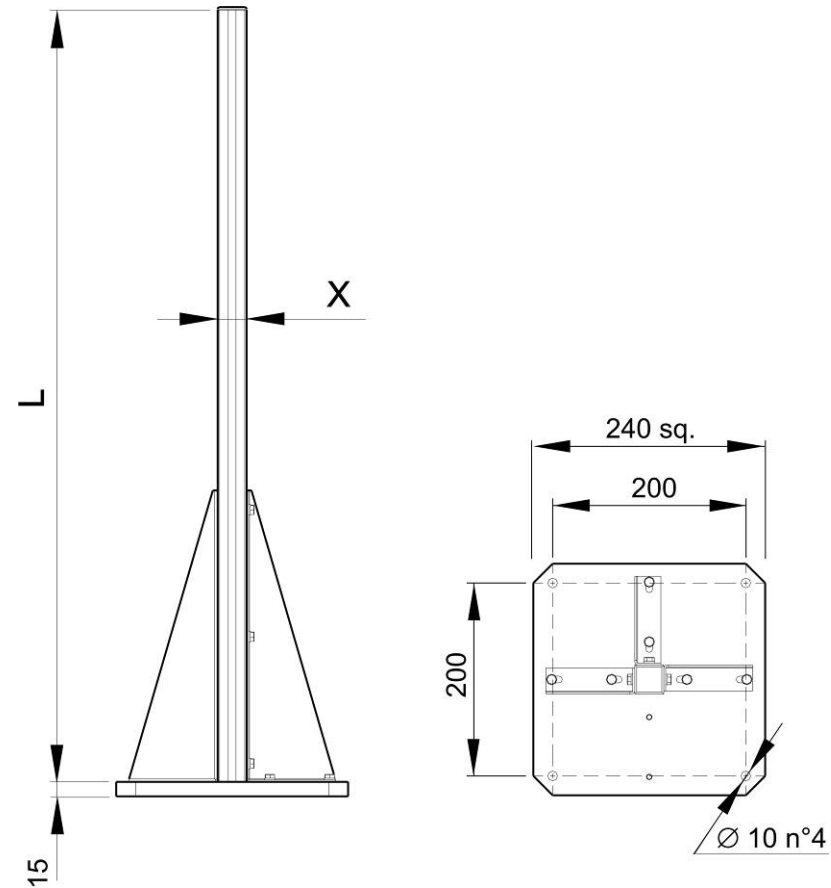

English

Protective stands

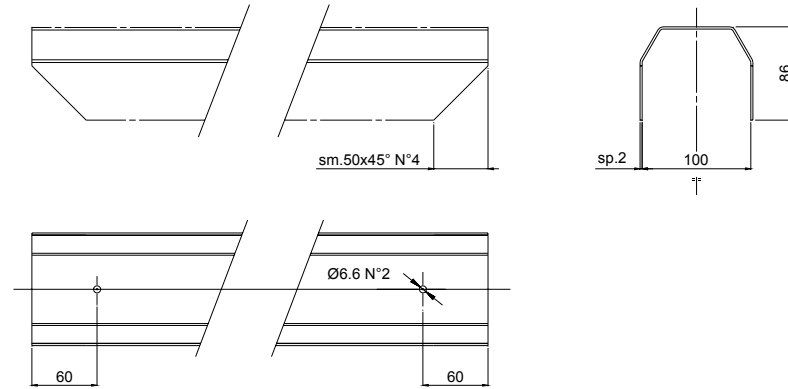

MODEL	DESCRIPTION	L (mm)
SE-P 600	Protective stand H= 714 mm	714
SE-P 750	Protective stand H= 861 mm	861
SE-P 800	Protective stand H= 969 mm	969
SE-P 900	Protective stand H= 1069 mm	1069
SE-P 1050	Protective stand H= 1155 mm	1155
SE-P 1200	Protective stand H= 1302 mm	1369
SE-P 1350	Protective stand H= 1449 mm	1449
SE-P 1500	Protective stand H= 1596 mm	1596
SE-P 1650	Protective stand H= 1743 mm	1743

## Connection cables

MODEL	DESCRIPTION
CV-A1-22-B-03	Axial shielded 4-pin 3 m cable
CV-A1-22-B-05	Axial shielded 4-pin 5 m cable
CV-A1-22-B-10	Axial shielded 4-pin 10 m cable
CV-A1-26-B-03	Axial shielded 8-pin 3 m cable
CV-A1-26-B-05	Axial shielded 8-pin 5 m cable
CV-A1-26-B-10	Axial shielded 8-pin 10 m cable
CV-A2-22-B-03	Radial shielded 4-pin 3 m cable
CV-A2-22-B-05	Radial shielded 4-pin 5 m cable
CV-A2-22-B-10	Radial shielded 4-pin 10 m cable
CV-A2-26-B-03	Radial shielded 8-pin 3 m cable
CV-A2-26-B-05	Radial shielded 8-pin 5 m cable
CV-A2-26-B-10	Radial shielded 8-pin 10 m cable
CS-A1-03-G-03 (*)	Axial no-shielded 5-pole 3 m
CS-A1-03-G-03 (*)	Axial no-shielded 5-pole 5 m
CS-A1-03-G-03 (*)	Axial no-shielded 5-pole 10 m

(\*) for connecting Muting sensors with the M12 5-pole connector in the SE4-RA1-PP-W version

English

## Safety relay

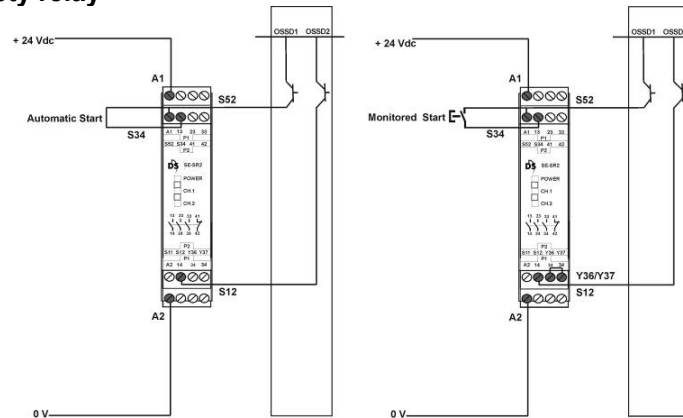

The drawing shows the connection between the **SAFEasy™** safety light curtain and the Type 4 safety relay of the **SE-SR2** series functioning in the automatic Restart mode (left side) and manual Restart with monitoring (right side).

MODEL	DESCRIPTION
SE-SR2	Type 4 safety relay - 3 NO 1NC

**Laser pointer**

The laser pointer of the **SE-LP** series represents a valid alignment and installation support for the SE4-R safety light curtain series. The pointer can be moved along the light curtain profile to verify the complete device alignment (top and bottom).

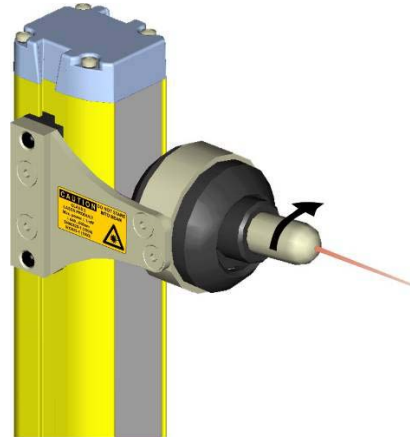

MODEL	DESCRIPTION
SE-LP	Laser pointer

**Connection box**

The **SE-SRT** connection box is used to facilitate the connection and use of the SE4-R. Two force-guided contact relays and a terminal block are inside the connection box to ease cabling.

MODEL	DESCRIPTION
SE-SRT	Muting connection box

