

Kemro

CP 265/X

CPU module

Project engineering manual V1.00

Translation of the original instructions

KEBA[®]

Automation by innovation.

Document : V1.00 / article no.: 1008447
Filename : cp265xpjen.pdf
Pages : 40

© KEBA 2012

Specifications are subject to change due to further technical developments. Details presented may be subject to correction.

All rights reserved.

A: KEBA AG, Gewerbepark Urfahr, A-4041 Linz, Tel.: +43 732 7090-0, Fax: +43 732 7309-10, E-Mail: keba@keba.com
D: KEBA GmbH Automation, Leonhard-Weiss-Straße 40, D-73037 Göppingen, Tel.: +49 7161 9741-0, Fax: +49 7161 9741-40, E-Mail: keba@keba.com
US: KEBA Corp., 100 West Big Beaver Road, Troy, MI 48084, US, Tel.: +1 248 526-0561, Fax: +1 248 526-0562, E-Mail: usa@keba.com
CN: Beijing Austrian KEBA Science and Technology Development Ltd., Room B516, Nan Xin Cang Tower, A22 Dong Si Shi Tiao, Dong Cheng District, Beijing, 100027, P.R. China, Tel. +86 10 6409-6592, Fax +86 10 6409-6312, E-Mail: china@keba.com

www.keba.com

Record of Revision

Version	Date	Change in chapter	Description	changed by
1.00	03-2012	-	Newly created	born, ekr, swb

Table of Contents

1	Introduction	7
1.1	Purpose of the document.....	7
1.2	Preconditions.....	7
1.3	Intended use.....	8
1.4	Notes on this document.....	8
	1.4.1 Contents of the document.....	8
	1.4.2 Not contained in this document.....	8
1.5	Documentation for further reading.....	8
1.6	EtherCAT declaration.....	9
2	Safety notes	10
2.1	Representation.....	10
2.2	General safety instructions.....	11
2.3	Safety instructions for personal safety.....	11
3	Description of the module	12
3.1	Front view.....	12
3.2	Compact Flash slot.....	12
	3.2.1 Precautions when using the CF card.....	13
	3.2.2 Inserting the Compact Flash card.....	13
	3.2.3 Removing the Compact Flash card.....	13
3.3	Accessories.....	14
	3.3.1 Compact Flash card.....	14
	3.3.2 Connector strip.....	14
4	Displays and operating elements	15
4.1	Diagnostic display (DIAG).....	15
4.2	Status LEDs.....	15
4.3	Program load key (CTRL).....	15
4.4	CAN Status LEDs.....	15
4.5	Ethernet status LEDs.....	16
5	Mounting and installation instructions	17
5.1	Mounting of the module.....	17
5.2	Inserting and removing of option modules.....	17
5.3	Adding modules.....	19
5.4	Air conditioning and ventilation.....	19
	5.4.1 Use of air filters.....	20
6	Connections and wiring	21
6.1	Power supply.....	21
	6.1.1 Connection example.....	22
6.2	Grounding.....	22
6.3	Graphic interface (PANEL / SI0).....	23
	6.3.1 Pin assignment.....	24

6.3.2	Cable and plug specification.....	24
6.4	CAN interface (CAN0).....	24
6.4.1	Pin assignment, connection example.....	24
6.4.2	Cable and plug specification.....	25
6.4.3	CAN bus termination.....	25
6.5	Ethernet interfaces (ETHERNET0-2).....	26
6.5.1	Pin assignment.....	26
6.5.2	Cable and plug specification.....	27
6.6	USB ports (USB0, USB1).....	27
6.6.1	Cable and plug specification.....	27
6.7	EMC and wiring guidelines.....	27
7	Configuration.....	28
7.1	Setting the K-Net address.....	28
8	Operating behavior.....	29
8.1	Failure of supply voltage.....	29
8.2	Response to module errors.....	29
9	Diagnosis.....	30
10	Maintenance.....	31
10.1	Battery.....	31
10.1.1	Battery type and service life.....	31
10.1.2	Replacing the battery.....	31
10.2	Fan.....	32
10.2.1	Service life.....	32
10.2.2	Replacing fan.....	32
11	Disposal.....	35
11.1	Disposal of the module.....	35
11.2	Disposal of the battery.....	35
12	Technical data.....	36
12.1	In general.....	36
12.2	Environmental conditions.....	36
12.3	Computer kernel.....	36
12.4	Interfaces.....	36
12.5	Dimensions.....	37
13	EC directives and standards.....	38
13.1	EC directives.....	38
13.2	Standards.....	38
13.2.1	General procedures and safety principles.....	38
13.2.2	EMC guideline.....	38
13.2.3	Electrical safety and fire protection.....	38
13.2.4	Environmental and surrounding conditions.....	38
13.3	Standards for the American market.....	38
13.3.1	UL test for industrial control equipment.....	38
14	Declaration of conformity.....	39

1 Introduction

1.1 Purpose of the document

This document describes the structure of the CP 265/X (CPU module).

Additionally, the installation and configuration is described enough to obtain an operationally ready module. "Ready for operation" means that the assembly is ready for the synchronization of the firmware and the application.

Information

This manual is not addressed to end costumers! Necessary safety notes for the end costumer have to be taken into the costumer manual in the respective national language by the machine builders and system providers.

1.2 Preconditions

This document contains information for persons with the following skills:

Target group	Knowledge and skills pre-requirement
Project engineer	<p>Basic technical training (University of Applied Science/University level, engineering degree or corresponding professional experience).</p> <p>Knowledge in:</p> <ul style="list-style-type: none"> • working mode of a PLC, • safety regulations, • the application.
Operator	<p>Basic technical training (Vocational high school, engineering degree or corresponding professional experience).</p> <p>Knowledge in:</p> <ul style="list-style-type: none"> • safety regulations, • working mode of machine or plant, • principal functions of the application, • system analysis and troubleshooting, • setting options at the operating installations.
Service technician	<p>Basic technical training (Vocational high school, engineering degree or corresponding professional experience).</p> <p>Knowledge in:</p> <ul style="list-style-type: none"> • working mode of a PLC, • safety regulations, • working mode of machine or plant, • diagnosis possibilities, • systematic error analysis and rectification.

1.3 Intended use

The CP 265/X was developed for control applications in industrial machines. The typical applications areas include injection molding machines, robots, presses, machine tools and similar.

The CP 265/X may only be used for the types of use described in the technical descriptions and only in conjunction with recommended/approved third-party equipment/installations.

The CP 265/X has been developed, manufactured, tested and documented in accordance with the appropriate safety standards. Therefore, the products do not pose any danger to the health of persons or a risk of damage to other property or equipment under normal circumstances, provided that the instructions and safety precautions relating to the intended use are properly observed.

1.4 Notes on this document

This manual is integral part of the product. It is to be retained over the entire life cycle of the product and should be forwarded to any subsequent owners or users of the product.

1.4.1 Contents of the document

- Description of the module
- Mounting and installation instructions
- Description of interfaces including EMC guidelines
- Description of the configuration
- Description of diagnostics functions
- Maintenance instructions
- Technical data

1.4.2 Not contained in this document

- Programming instruction
- Application diagnosis
- Firmware description

1.5 Documentation for further reading

The following documents are to be observed depending on the system solution used:

If you are using the KeStudio U2 tool suite:

Doc.No.	Name	Target group
DE: 65352 EN: 65353	K2-200 automation system manual	<ul style="list-style-type: none"> • Project engineer • Electrician • Programmer • Commissioning foreman • Service technician

If you are using the KeStudio U3 tool suite:

Doc.No.	Name	Target group
DE: 1000868 EN: 1000869	System manual Kemro automation system	<ul style="list-style-type: none"> • Project engineer • Electrician • Programmer • Commissioning foreman • Service technician

1.6 EtherCAT declaration



EtherCAT® is registered trademark and patented technology, licensed by Beckhoff Automation GmbH, Germany .

2 Safety notes

2.1 Representation

At various points in this manual you will see notes and precautionary warnings regarding possible hazards. The symbols used have the following meaning:



DANGER!

- indicates an imminently hazardous situation which will result in death or serious bodily injury if the corresponding precautions are not taken.
-



WARNING!

- indicates a potentially hazardous situation which can result in death or serious bodily injury if the corresponding precautions are not taken.
-



CAUTION!

- means that if the corresponding safety measures are not taken, a potentially hazardous situation can occur that may result in property injury or slight bodily injury.
-

CAUTION

- CAUTION used without the safety alert symbol indicates a potentially hazardous situation which, if not avoided, may result in damage to property.
-



- This symbol reminds you of the possible consequences of touching electrostatically sensitive components.
-

Information

Useful practical tips and information on the use of equipment are identified by the "Information" symbol. They do not contain any information that warns about potentially dangerous or harmful functions.

2.2 General safety instructions



WARNING!

- It is absolutely essential that you also observe the safety instructions in the system manual for your automation system.
 - The following areas of application are expressly excluded for the CPU module:
 - Use in areas where there is a risk of explosion or fire
 - Use in the mining sector
 - Use in the open airOther products are to be used for these applications!
 - The CPU module is not designed for safety-relevant control tasks (e.g.: shutdown in case of an emergency). For safety-relevant control tasks and personnel security, additional external safety measures must be implemented to ensure the system remains in a safe operating condition even in the event of a fault.
 - At the development of the CPU module the standard EN ISO 13849-1 was not considered.
 - The module is defined as "open type equipment" (UL 508) or as "open equipment" (EN 61131-2) and must therefore be installed in a control cabinet.
-

CAUTION

Improper use of the assembly or the control system leads to irreparable damage!

- Turn off the power supply before inserting or removing the module. Otherwise, the module can be destroyed or undefined signal states can lead to damage of the control system.
-

2.3 Safety instructions for personal safety



WARNING!

Danger of personal injury due to electric shock!

- Supply the KEBA control exclusively from power sources that have a protective low voltage (e.g. SELV or PELV according to EN 61131-2).
 - Connect only voltages and power circuits to connections, terminals and interfaces up to 50 V rated voltage that have a secure disconnect for hazardous voltages (e.g. with sufficient isolation and voltage-proof).
-



CAUTION!

Fire hazard during module failure!

- Provide suitable fuses for the 24 V DC power supply of the control system for the final application! (for details, refer to the Power supply section).
-

3 Description of the module

The CPU module is an intelligent master module designed for a medium-range performance within the Kemro automation system.

3 slots for option modules are available for extensions.

3.1 Front view

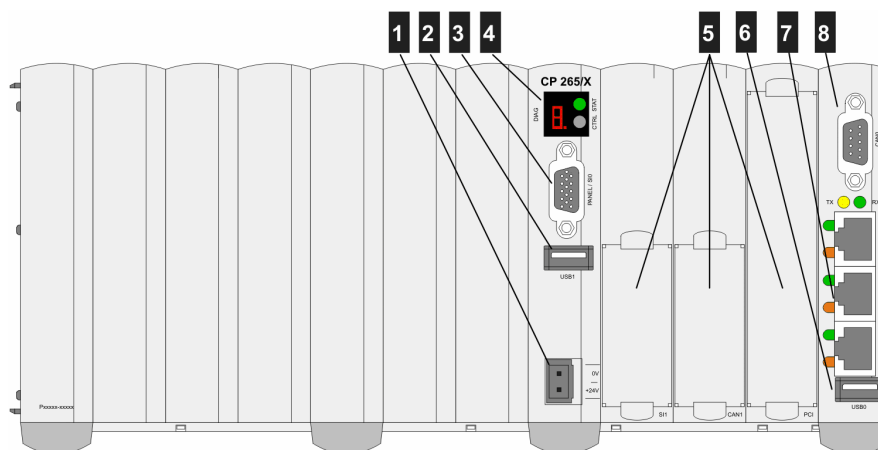

Fig.3-1: Front view CP 265/X

1 ... Power supply	2 ... USB port (USB1)
3 ... Graphic interface	4 ... Diagnosis display
5 ... 3 slots for option modules	6 ... USB port (USB0)
7 ... Ethernet interfaces	8 ... CAN interface

3.2 Compact Flash slot

To operate the CP 265/X, a Compact Flash card with the firmware and the application must be plugged into the Compact Flash slot.

For more information for the directory structure on the Compact Flash card, please see the system manual for your automation system.

3.2.1 Precautions when using the CF card

CAUTION

Improper insertion can cause damage to the contact pins.

Do not use force when inserting the Compact Flash card into the slot. It is constructed so that it can only be inserted in one direction and it should slide into the slot easily with little force.

The card:

- should be kept away from moisture, heat and direct sunlight,
- should be protected against static electricity,
- should not be dropped or bent.
- should not be removed or the device switched off while the card is being written to.

3.2.2 Inserting the Compact Flash card

- 1) Turn off the power supply.
- 2) Insert the Compact Flash card (see drawing).

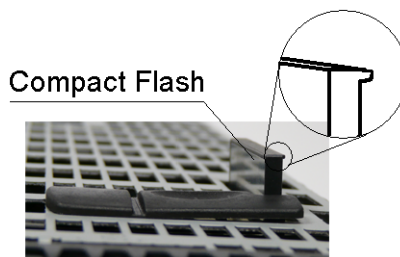

Fig.3-2: Inserting the CF card

3.2.3 Removing the Compact Flash card

- 1) Turn off the power supply.
- 2) Press the eject button (1, see drawing).
- 3) Pull out the Compact Flash card (2).

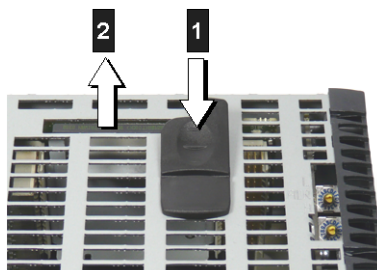

Fig.3-3: Removing the CF card

3.3 Accessories

3.3.1 Compact Flash card

Information

Use only Compact Flash cards which are approved by KEBA . A proper function is not guaranteed when using other Compact Flash cards.

The approved Compact Flash cards may be requested and ordered by KEBA.

3.3.2 Connector strip

Socket board	Color	Number	Weidmüller order number
2-pole	sw	1	BLZF 5.08/2 SN SW - 170769

The appropriate female connectors are not included in the delivery of KEBA, but can be purchased from KEBA.

The technical data for the terminals are contained in the technical data sheet of the manufacturer of the female connectors.

For further information see System manual.

4 Displays and operating elements

4.1 Diagnostic display (DIAG)

A single-digit 7-segment display on the front side indicates the start-up modes and error codes.

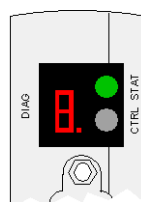

Fig.4-1: Diagnosis display and CTRL key

Further information: See system manual.

4.2 Status LEDs

The multi-colored status LED on the CPU module is located above the program loading button (CTRL).

Display	Significance
Dark	No supply voltage
Flashing green	Initialization phase
Green	Operation
Flashing red	Error on module (e.g. overload, line interruption, etc.)
Red	Fatal module error – the module is out of operation.

4.3 Program load key (CTRL)

The program load key (CTRL) is located next to the 7-segment-display on the right. Different functions can be executed with the key, e.g. switching over the control to a different operating state.

Further information: See system manual.

4.4 CAN Status LEDs

The module has two CAN Status LEDs (RX- and TX-LEDs) per CAN interface, which are activated from the Microcontroller.

Display	Significance
RX-LED (green)	briefly lights up on receipt of a CAN-message.
TX-LED (yellow)	briefly lights up on transmission of a CAN-message.

4.5 Ethernet status LEDs

The Ethernet-socket (RJ-45) offers a Link-Status-LED and an Activity-LED.

Display	Significance
Link-Status-LED (green)	Lights up as soon as an Ethernet connection is available.
Activity-LED	Lights up when sending and receiving data.

5 Mounting and installation instructions

5.1 Mounting of the module

Further information: See system manual.

5.2 Inserting and removing of option modules

The front side of the CP 265/X provides 3 slots for the option modules. Modules from the Kemro series can be inserted into these slots.

Assignment of the slots

- Left slot
1
 - SX 210/A for RS 232
 - SX 220/A for Current-Loop
 - SX 230/A for RS-485-A, RS-422-A
- Middle slot
2
 - FX 200/A for CAN
- Right slot
3
 - NX 252/A for Ethernet
 - BX 250/A for K-Net
 - BX 252/A for K-Net, Ethernet
 - FX 271/C for Sercos, Ethernet

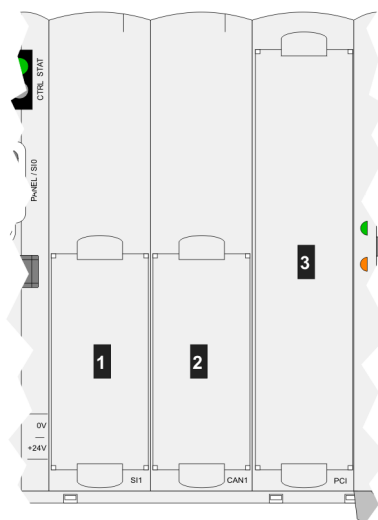

Fig.5-1: Assignment of the slots



- Slots not used must be closed with reserve modules to secure contact protection of the ESD-sensitive parts.

Information

The option modules may not be plugged or removed, if the CP 265/X is activated.

Weitere Informationen für den Anschluss und Betrieb: Siehe Projektierungshandbücher der verwendeten Optionsmodule.

Inserting an option module into slot

- 1) Turn off power supply
- 2) Remove dummy module
- 3) Insert module in the right position (labeling of option module must on the right) into the intended position (see image).

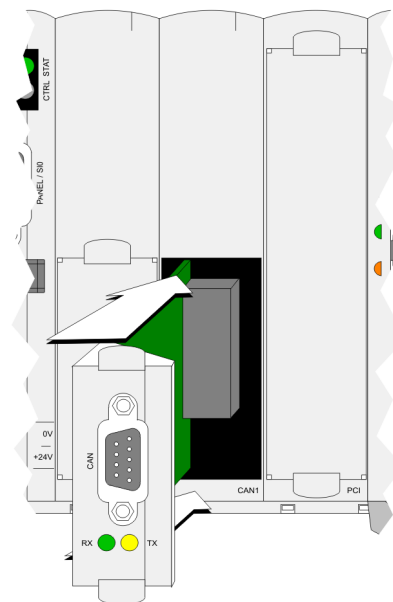

Fig.5-2: Inserting the option module into slot

Removing an option module

- 1) Turn off power supply
- 2) Pull module out of the slot
- 3) Insert dummy module.

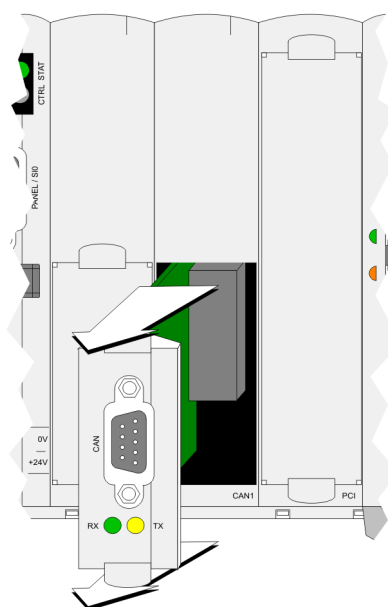

Fig.5-3: Removing the option module

5.3 Adding modules

The CP 265/X makes the following output available for up to 12 add-on modules:

Output power on the K-Bus (5 V):	10 W
Output power on the K-Bus (24 V):	45 W

To guarantee stable functioning of the module cluster the power demand on the added-on modules must not exceed the specified power values.

Information

For the calculation of the number of modules that can be added, the performance values specified in the technical data of the respective project engineering manual under "Power consumption 5 V on the K-Bus" and "Power consumption 24 V on the K-Bus" must be used.

For further information: See system manual.

Further information: See system manual.

5.4 Air conditioning and ventilation

The module is equipped with ventilation holes for heat dissipation. Make sure that the ventilation holes are not covered.

The CP 265/X is also equipped with an internal ventilator. For further information on the ventilator, please consult the maintenance section of this manual.



CAUTION!

High temperatures may destroy the module!

- The operating temperature inside the control cabinet must not be higher than the permissible ambient temperature of the module. If this cannot be guaranteed through natural heat dissipation, an air conditioning of the control cabinet must be provided.

Information

There must be a free space of at least 30 mm above and below the modules to guarantee head dissipation.

5.4.1 Use of air filters

To ensure that the contamination does not exceed contamination level 2 (according to EN 61131-2), the control must be installed in a dustproof, closed control cabinet. Fan openings of the control cabinet must be equipped with air filters. The filter elements must be cleaned or replaced regularly.

Information

Contamination level 2, description according to standard:

"The occurring contamination is generally not conductive. However, temporary conductivity must be expected due to condensation."

6 Connections and wiring

6.1 Power supply

The 24 V terminal supplies the CP 265/X and all add-on modules.

To avoid problems with the electrical potential and stray electric current all 0 V potential have to be linked on a neutral point with a ground rail.

Additionally a shield rail for the connections of all shields of the cables has to be used.



WARNING!

Danger of personal injury due to electric shock!

- Supply the device exclusively from power sources that have an extra low voltage (e.g. SELV or PELV according to EN 61131-2)
 - Connect only voltages and power circuits to connections, terminals and interfaces up to 50 V rated voltage that have a secure disconnect for hazardous voltages (e.g. with sufficient isolation).
-



CAUTION!

Fire hazard during module failure!

- Provide suitable fuses for the 24 V DC power supply for the final application. Only fuses with a maximum nominal disconnecting current of 10 A may be used.
-

Section

Refer to the manufacturer-specific data sheet of the of the female connectors used for type, cross-section and material. For further information: See chapter Accessories.

The actual permissible wire cross-section is specified by the electrical conditions of the connected equipment an the female connectors used:

- Max. load current and required heat dissipation through the connected wire at maximum ambient temperature.
- Permissible voltage drop for error-free operation of the connected equipment.

6.1.1 Connection example

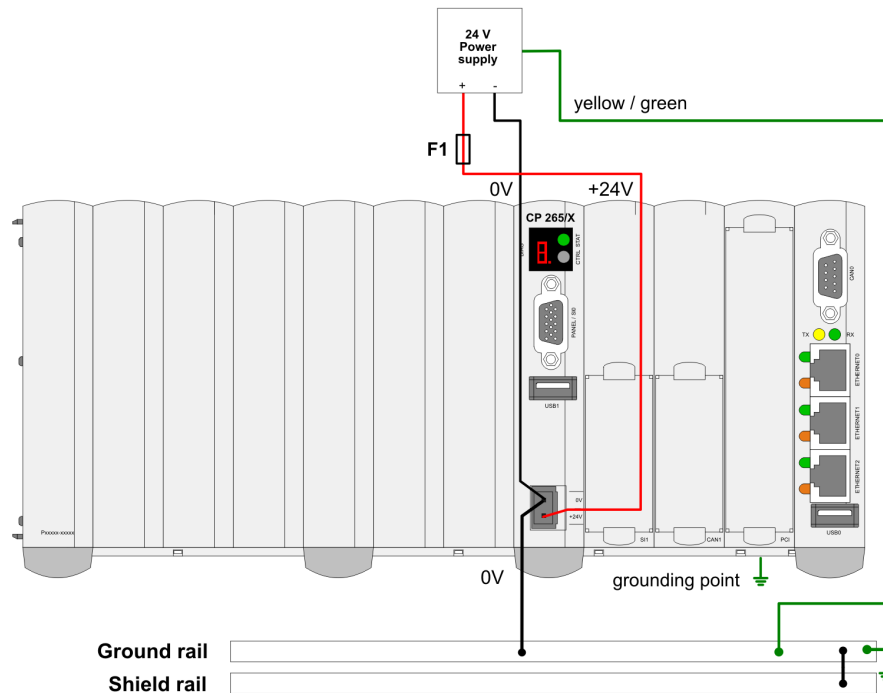

Fig.6-1: Power supply

Fuse F1

The rated current for fuse F1 is dependent on the power consumption of the added-on modules.

6.2 Grounding

If required for reasons of electrical safety for the end usage, the metal parts of the module have to be grounded via the threaded bushing (M4) that is located on the underside of the casing (grounding point).

Material: Electrolytic galvanized sheet steel, blue galvanized self-clinching standoff.

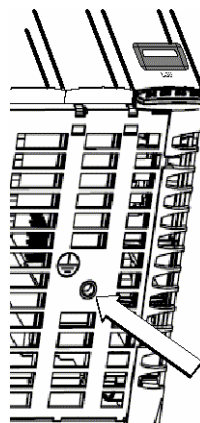

Fig.6-2: Position of the grounding point

6.3 Graphic interface (PANEL / SI0)

The graphic interface is used to connect an operating panel (DVI interface).

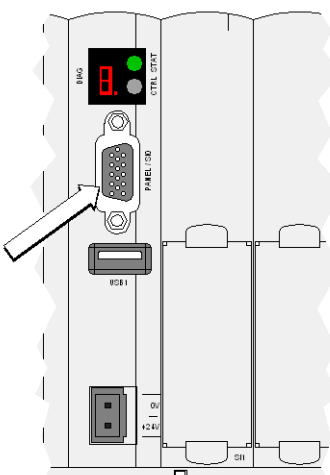
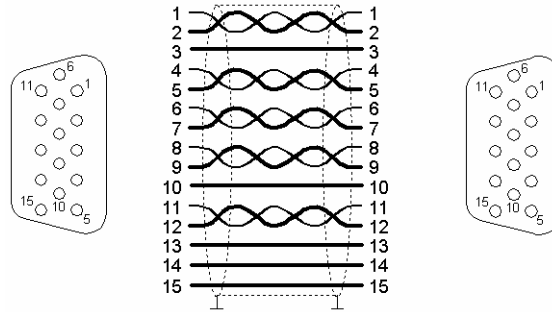

Fig.6-3: Position of the graphic interface

6.3.1 Pin assignment



01 ... CLK+ (Pair 1)	02 ... CLK- (Pair 1)
03 ... +5 V	04 ... RS485+ (pair 2)
05 ... RS485- (pair 2)	06 ... DATA0+ (Pair 3)
07 ... DATA0- (Pair 3)	08 ... DATA1+ (Pair 4)
09 ... DATA1- (Pair 4)	10 ... GND (connect via free line or via cable shield)
11 ... DATA2+ (Pair 5)	12 ... DATA2- (Pair 5)
13 ... SDA	14 ... SDC
15 ... Panel-present	

6.3.2 Cable and plug specification

Further information: See system manual.

6.4 CAN interface (CAN0)

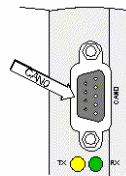

Fig.6-4: Position of the CAN interface (CAN0)

6.4.1 Pin assignment, connection example

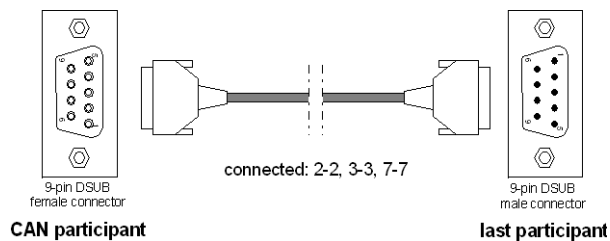

Fig.6-5: CAN connection at the module: 9-pole D-SUB male connector

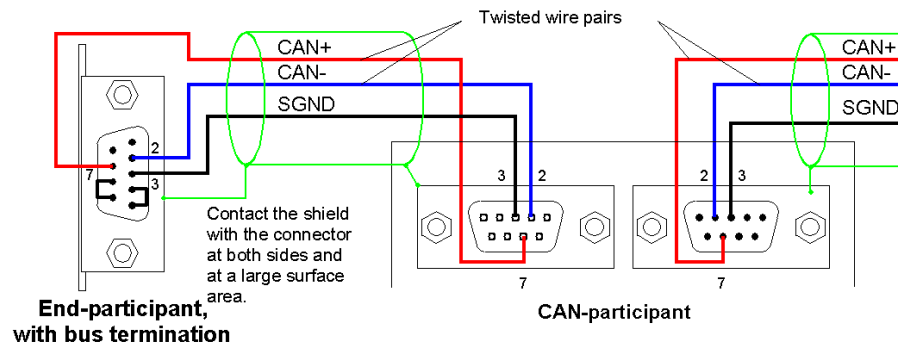

Fig.6-6: Connection example for CAN circuit

Information

Both SGND (Signal Ground) and GND (optional ground) connections are connected internally. The designation was selected to correspond with the standard CiA (CAN in Automation).

Further information: See system manual.

6.4.2 Cable and plug specification

Further information: See system manual.

6.4.3 CAN bus termination

To activate the bus termination at the first and last participant, both the pins 4 and 5 (TERM1) must be connected as well as the pins 8 and 9 (TERM2).

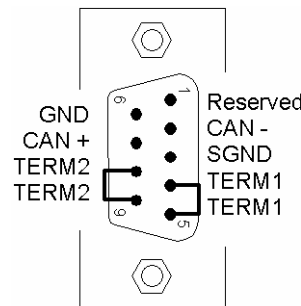

Fig.6-7: CAN interface with activated bus termination

6.5 Ethernet interfaces (ETHERNET0-2)

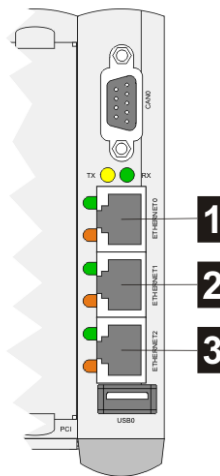

Fig.6-8: Position of the Ethernet interfaces

1 ... ETHERNET0	2 ... ETHERNET1 / EtherCAT
3 ... EtherCAT / ETHERNET2	

Information

Take the slot EtherCat / ETHERNET2 (**3**) by using one EtherCAT.

Take the slots ETHERNET1 / EtherCAT and EtherCAT / ETHERNET2 (**2** and **3**) by using two EtherCAT.

6.5.1 Pin assignment

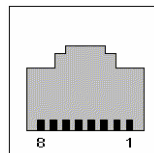

Fig.6-9: Ethernet connection

Pin no.	Signal designation		Input / Output
1	Tr. Data +	Transmit Data +	Output
2	Tr. Data -	Transmit Data -	Output
3	Re. Data +	Receive Data +	Input
4	Bi-Data +	n.c.	---
5	Bi-Data -	n.c.	---
6	Re-Data-	Receive Data -	Input
7	Bi-Data +	n.c.	---
8	Bi-Data -	n.c.	---

6.5.2 Cable and plug specification

Further information: See system manual.

6.6 USB ports (USB0, USB1)

2 ports are available to connect external USB-devices.

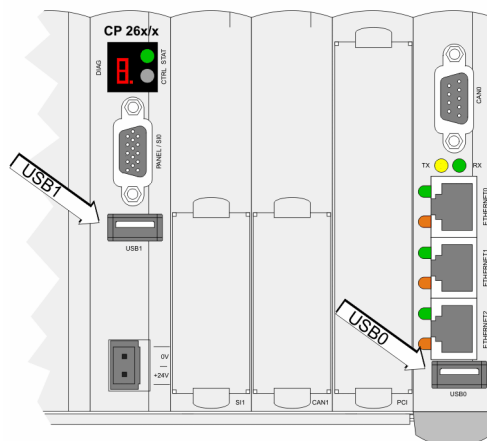

Fig.6-10: Position of the USB ports

Further information: See system manual.

CAUTION

- The use of common USB devices may result in unexpected system behavior or system failures, as these devices are not normally designed for operation in an environment with industrial interference.
- Never keep USB-devices constantly connected, as the USB-ports are not operationally reliable (danger of unplugging).
- For constant operations use a strain relief.

6.6.1 Cable and plug specification

Further information: See system manual.

6.7 EMC and wiring guidelines

Pay attention from the outset to careful wiring and shielding.

Further information: See system manual.

7 Configuration

General information

A Kemro system needs data for the configuration of system performance, its I/O-devices and interfaces. The system reads this data during the start-up operation and allocates them to its components and devices.

Configuration data is created by included configuration tools or by editing configuration files.

For further information to the configuration see the documentation of the included configuration tool.

7.1 Setting the K-Net address

Different masters have to be identified via the addressing in the K-Net multi master operating mode.

The station address of the CP 265/X is entered via the delivered tool.

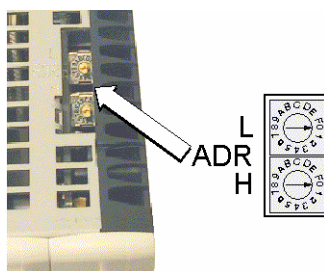

Fig.7-1: Position of address switches

On leaving the factory, all modules are set to address 0.

The CP 265/X has no onboard K-Net. To use K-Net the option module BX 250/A has to be used.

8 Operating behavior

8.1 Failure of supply voltage

In case of a complete power supply failure a Reset is triggered. All lined-up modules are also set into reset-status and all outputs are switched off.

Data in the battery-buffered SRAM remain intact and the real-time clock continues to run.

8.2 Response to module errors

In case an error occurs, this error will be displayed on the diagnosis display on the front side of the CP 265/X.

Further information: See system manual.

9 Diagnosis

The module has a 7-segment display for signalling status information and error codes.

Further information: See system manual.

10 Maintenance

10.1 Battery

10.1.1 Battery type and service life

Battery type:	CR2032 (Lithium-Mn, 3 V/220 mAh)
Service life:	min. 3 years, typically 5 years

10.1.2 Replacing the battery

CAUTION

- **Do not use force!**
Otherwise you risk breaking the holder.
 - **Risk of explosion!**
Improper exchange of the battery, replacement of the battery by a different type or non-observance of the polarity can lead to irreparable damage to the battery.
 - **New batteries should not be touched with bare fingers because this could cause contact problems due to oxidation.**
 - **If the battery is not replaced when there is a warning message, the retain data can be lost if the front panel supply power is interrupted.**
-

The battery is located in the battery case on the top side of the housing and may only be replaced with a battery of the same type.

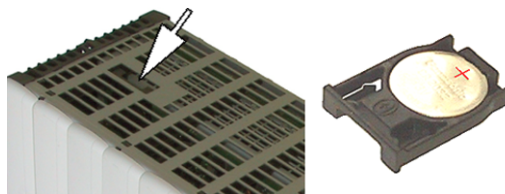

Fig.10-1: Position and view of battery case

- 1) To prevent a loss of data, the **power supply** must not be disconnected when replacing the battery.
 - 2) Remove battery case.
 - 3) Remove old battery and replace it with new battery. **Pay attention to polarity!**
 - 4) Re-insert battery case into CP 265/X.
-

CAUTION

- **If the battery is inserted incorrectly, the retain data is lost if the front panel power supply is interrupted.**
-

10.2 Fan

10.2.1 Service life

Service life: minimum of 3 years, typically 5 years.

10.2.2 Replacing fan

CAUTION

- **Operation without fan is not permitted since this could overheat the module and destroy it.**
-

The fan located in the fan case on the bottom of the housing may only be replaced with a fan of the same type.

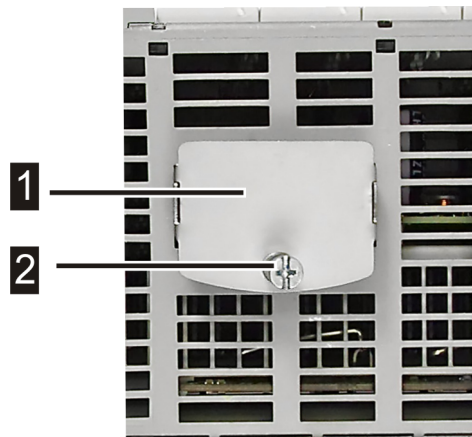

Fig.10-2: Fan case. Position on the bottom of the housing

- | | |
|----------|--|
| 1 | ... Back side of the fan case |
| 2 | ... Fastening screw with pressure spring |

The fan case with fan must be obtained from KEBA.



Fig.10-3: Fan case with fan

1 ... Connector
2 ... Fastening screw with pressure spring

Ordering information

Designation	Comment	Order number
Fan case with cae	for CP 25x moduls	76105

Replacing the fan

CAUTION

Do not use force!

Otherwise you risk bending the connections on the ventilator case.

Replace fan according to the following the instructions:

- 1) Disconnect power supply.
- 2) If necessary dismount the module.
- 3) Loose the screw on the fan case with a screwdriver. By reason of the spring the loosen screw would not get seperate from the fan case.
- 4) Pull out fan case in a straight way.
- 5) Insert new fan with fan case. Pay attention to the mounting direction, like displayed in the picture.

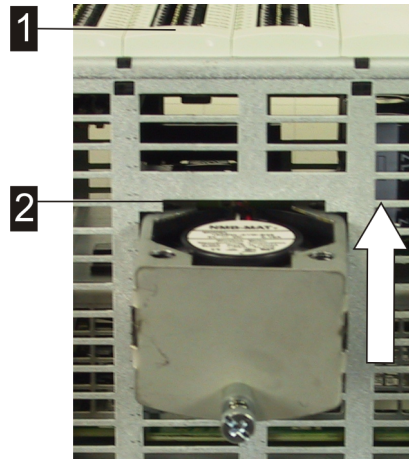

1 ... Front of the housing, direction upwards

2 ... Cut for fan case

Information

The fan case has to be inserted straight into the slot, otherwise the internal connector would not plug in.

6) Fix the fan case with the screw.

The fan is now replaced.

11 Disposal

11.1 Disposal of the module

CAUTION

Please observe the regulations regarding disposal of electric appliances and electronic devices!



- The symbol with the crossed-out waste container means that electrical and electronic devices including their accessories must not be disposed of in the household garbage.
- The materials are recyclable in accordance with their labeling. You can make an important contribution to protecting our environment by reusing, renewing and recycling materials and old appliances.

11.2 Disposal of the battery

CAUTION

- Pay attention to hazardous waste regulations when disposing of batteries.
 - Although batteries have a low voltage, they can provide enough current when short-circuited to ignite flammable material. They should not be disposed of together with conductive material (e.g. iron filings, wire wool contaminated with oil, etc.)
-

12 Technical data

12.1 In general

Power supply voltage:	24 V DC
Max. switch-on current:	10 A
Overvoltage category:	II
Equipment class:	III according to En 61131-2
Galvanic isolation:	No
Max. total power consumption:	Approximate value: 99 W - tests in progress
Power consumption own consumption:	Approximate value: 38 W - tests in progress
Max. output power K-Bus 24 V:	Approximate value: 40 W - tests in progress
Max. output power K-Bus 5 V:	Approximate value: 10 W - tests in progress
Fan:	Unit fan, replaceable from the outside.
Protection class:	IP20

12.2 Environmental conditions

Operating temperature:	+5 °C to +55 °C
Storage temperature:	-40 °C to 70 °C
Relative humidity of air:	10 % to 95 % (non condensing)
Vibration resistance:	according to EN 61131-2:2007
Shock resistance:	according to EN 61131-2:2007

12.3 Computer kernel

Processor:	Embedded Processor - Intel Atom 1,8 GHz
Memory:	1 GB DDR3 SDRAM
Battery-buffered SRAM:	1 MB

12.4 Interfaces

CAN interface (onboard):	Communication with periphery components
CAN bus baudrates:	To be set via software (max. 1 Mbaud)
Ethernet:	10/100 Mbit/s
USB:	USB 2.0; high speed
Compact Flash:	Typ 1
Possibilities of plugs for serial interface:	For serial interface module (Kemro-K2 series)
Possibilities for plugs for CAN extension module:	For CAN module (Kemro-K2 series)
Possibilities for plugs for PCI modules:	For BX 250, NX 250, BX 252, FX 271
DVI + RS-485-A:	Graphic interface for panel (e.g. OP 362, ...)

12.5 Dimensions

Footprint:	
• Height:	120 mm
• Width:	270 mm
• Depth:	100 mm
Weight:	1335 g

13 EC directives and standards

13.1 EC directives

Guideline 2004/108/EG	EC guideline on electromagnetic compatibility
Guideline 2002/95/EG	RoHS guideline

13.2 Standards

To check the conformity of the system with the directives, the following non-binding legal European standards were applied:

13.2.1 General procedures and safety principles

EN 61131-1:2003	Programmable controllers - Part 1
-----------------	-----------------------------------

Information

This product was developed for the use in industrial areas and can cause radio interference when used in residential areas.

13.2.2 EMC guideline

EN 61131-2:2007	Programmable controllers - Part 2
-----------------	-----------------------------------

13.2.3 Electrical safety and fire protection

EN 61131-2:2007	Programmable controllers - Part 2
-----------------	-----------------------------------

13.2.4 Environmental and surrounding conditions

EN 61131-2:2007	Programmable controllers - Part 2
-----------------	-----------------------------------

13.3 Standards for the American market

13.3.1 UL test for industrial control equipment

UL 508, 2005	Industrial Control Equipment
--------------	------------------------------

14 Declaration of conformity



EC Declaration of Conformity



KEBA AG
Gewerbepark Urfahr
4041 Linz
AUSTRIA

Document No.: 87889/CE

We declare that the following product(s)

Name of product: CP 265

Variants: CP 265/W (Mat.Nr.: 87889), CP 265/X (Mat.Nr.: 87890)

is/are in conformity with the essential requirements of the following European Council Directive(s):

- EC-Directive relating to electromagnetic compatibility 2004/108/EC

Conformity to the directive 2004/108/EC is assured by the compliance with the applicable parts of the following harmonized european standards:

- EN 61131-2:2007

Important notes:

Any modification on the product(s), or of the manuals that is performed without KEBA's consent will render this declaration invalid.

This declaration certifies the conformity with the directives mentioned, but does not imply any warranty of the features of the product(s).

The safety instructions contained in the documentation supplied with the product(s) must be followed.

