

Right choice for ultimate yield

LSIS strives to maximize customers' profit in gratitude of choosing us for your partner.

Programmable Logic Controller

High Speed Counter

XGT Series

User's Manual

XGF-HO2A XGF-HD2A



Safety Instructions

- Read this manual carefully before installing, wiring, operating, servicing or inspecting this equipment.
- Keep this manual within easy reach for quick reference.

LS Industrial Systems

Before using the product ...

For your safety and effective operation, please read the safety instructions thoroughly before using the product.

- ▶ Safety Instructions should always be observed in order to prevent accident or risk with the safe and proper use the product.
- ▶ Instructions are divided into “Warning” and “Caution”, and the meaning of the terms is as follows.

 **Warning** This symbol indicates the possibility of serious injury or death if some applicable instruction is violated

 **Caution** This symbol indicates the possibility of severe or slight injury, and property damages if some applicable instruction is violated

Moreover, even classified events under its caution category may develop into serious accidents relying on situations. Therefore we strongly advise users to observe all precautions properly just like warnings.

- ▶ The marks displayed on the product and in the user’s manual have the following meanings.

 Be careful! Danger may be expected.

 Be careful! Electric shock may occur.

- ▶ The user’s manual even after read shall be kept available and accessible to any user of the product.

Safety Instructions for design process

Warning

- ▶ **Please install a protection circuit on the exterior of PLC so that the whole system may operate safely regardless of failures from external power or PLC.** Any abnormal output or operation from PLC may cause serious problems to safety in whole system.
 - Install protection units on the exterior of PLC like an interlock circuit that deals with opposite operations such as emergency stop, protection circuit, and forward/reverse rotation or install an interlock circuit that deals with high/low limit under its position controls.
 - If any system error (watch-dog timer error, module installation error, etc.) is detected during CPU operation in PLC, all output signals are designed to be turned off and stopped for safety. However, there are cases when output signals remain active due to device failures in Relay and TR which can't be detected. Thus, you are recommended to install an addition circuit to monitor the output status for those critical outputs which may cause significant problems.
- ▶ **Never overload more than rated current of output module nor allow to have a short circuit.** Over current for a long period time may cause a fire .
- ▶ **Never let the external power of the output circuit to be on earlier than PLC power,** which may cause accidents from abnormal output operation.
- ▶ **Please install interlock circuits in the sequence program for safe operations in the system when exchange data with PLC or modify operation modes using a computer or other external equipments** Read specific instructions thoroughly when conducting control operations with PLC.

Safety Instructions for design process

Caution

- ▶ **I/O signal or communication line shall be wired at least 100mm away from a high-voltage cable or power line.** Fail to follow this

Safety Instructions on installation process

Caution

- ▶ **Use PLC only in the environment specified in PLC manual or general standard of data sheet.** If not, electric shock, fire, abnormal operation of the product may be caused.
- ▶ **Before install or remove the module, be sure PLC power is off.** If not, electric shock or damage on the product may be caused.
- ▶ **Be sure that every module is securely attached after adding a module or an extension connector.** If the product is installed loosely or incorrectly, abnormal operation, error or dropping may be caused. In addition, contact failures under poor cable installation will be causing malfunctions as well.
- ▶ **Be sure that screws get tighten securely under vibrating environments.** Fail to do so will put the product under direct vibrations which will cause electric shock, fire and abnormal operation.
- ▶ **Do not come in contact with conducting parts in each module,** which may cause electric shock, malfunctions or abnormal operation.

Safety Instructions for wiring process

Warning

- ▶ **Prior to wiring works, make sure that every power is turned off.** If not, electric shock or damage on the product may be caused.
- ▶ **After wiring process is done, make sure that terminal covers are installed properly before its use.** Fail to install the cover may cause electric shocks.

Caution

- ▶ **Check rated voltages and terminal arrangements in each product prior to its wiring process.** Applying incorrect voltages other than rated voltages and misarrangement among terminals may cause fire or malfunctions.
- ▶ **Secure terminal screws tightly applying with specified torque.** If the screws get loose, short circuit, fire or abnormal operation may be caused. Securing screws too tightly will cause damages to the module or malfunctions, short circuit, and dropping.
- ▶ **Be sure to earth to the ground using Class 3 wires for FG terminals which is exclusively used for PLC.** If the terminals not grounded correctly, abnormal operation or electric shock may be caused.
- ▶ **Don't let any foreign materials such as wiring waste inside the module while wiring,** which may cause fire, damage on the product or abnormal operation.
- ▶ **Make sure that pressed terminals get tighten following the specified torque. External connector type shall be pressed or soldered using proper equipments.**

Safety Instructions for test-operation and maintenance

Warning

- ▶ **Don't touch the terminal when powered.** Electric shock or abnormal operation may occur.
- ▶ **Prior to cleaning or tightening the terminal screws, let all the external power off including PLC power.** If not, electric shock or abnormal operation may occur.
- ▶ **Don't let the battery recharged, disassembled, heated, short or soldered.** Heat, explosion or ignition may cause injuries or fire.

Caution

- ▶ **Do not make modifications or disassemble each module.** Fire, electric shock or abnormal operation may occur.
- ▶ **Prior to installing or disassembling the module, let all the external power off including PLC power.** If not, electric shock or abnormal operation may occur.
- ▶ **Keep any wireless equipment such as walkie-talkie or cell phones at least 30cm away from PLC.** If not, abnormal operation may be caused.
- ▶ **When making a modification on programs or using run to modify functions under PLC operations, read and comprehend all contents in the manual fully.** Mismanagement will cause damages to products and accidents.
- ▶ **Avoid any physical impact to the battery and prevent it from dropping as well.** Damages to battery may cause leakage from its fluid. When battery was dropped or exposed under strong impact, never reuse the battery again. Moreover skilled workers are needed when exchanging batteries.

Safety Instructions for waste disposal



Caution

- ▶ **Product or battery waste shall be processed as industrial waste.** The waste may discharge toxic materials or explode itself.

Revision History

Version	Date	Remark	Page
V 1.0	2006.05	First Edition	-
V 1.1	2007.09	1. Added the contents (1) Auto-registration the variable of special module (2) Instruction and Function Block (3) Global Constant (4) Global Variable 2. Updated the contents (1) Function (2) XG5000 execution (3) Parameter setting (4) Monitoring and Test (5) Auto-registration U device (6) Program (7) Terminology Description	- 4-10~4-11 7-1~7-7 6-1~6-3 6-4 2-8~2-26 4-1~4-3 4-4~4-5 4-6~4-7 4-8~4-9 7-8~7-29 Appendix 1-1~ Appendix 1-2
V1.2	2009.06	1. Added the contents of XGR CPU Module (1) Notes (2) XG5000 execution, Global constant (3) Program 2. Added GM Function Block Conversion Program	2-2 4-1,4-3,6-1 7-1~7-29 Appendix 3

※ The number of User's manual is indicated right part of the back cover.

Copyright © 2006 LS Industrial Systems Co., Ltd All Rights Reserved.

Thank for purchasing PLC of LS Industrial System Co.,Ltd.

Before use, make sure to carefully read and understand the User's Manual about the functions, performances, installation and programming of the product you purchased in order for correct use and importantly, let the end user and maintenance administrator to be provided with the User's Manual.

The User's Manual describes the product. If necessary, you may refer to the following description and order accordingly. In addition, you may connect our website (<http://eng.lsis.biz/>) and download the information as a PDF file.

Relevant User's Manuals

Title	Description
XG5000 User's Manual	XG5000 software user manual describing online function such as programming, print, monitoring, debugging by using XGK, XGB CPU
XG5000 User's Manual (for XGI, XGR)	XG5000 software user manual describing online function such as programming, print, monitoring, debugging by using XGI, XGR CPU
XGK/XGB Instructions & Programming User's Manual	User's manual for programming to explain how to use instructions that are used PLC system with XGK, XGB CPU.
XGI/XGR Instructions & Programming User's Manual	User's manual for programming to explain how to use instructions that are used PLC system with XGI, XGR CPU.
XGK CPU User's Manual (XGK-CPUA/CPUE/CPUH/CPUS/CPUU)	XGK-CPUA/CPUE/CPUH/CPUS/CPUU user manual describing about XGK CPU module, power module, base, IO module, specification of extension cable and system configuration, EMC standard
XGI CPU User's Manual (XGI-CPUU/H/S)	XGI-CPUU/H/S user manual describing about XGK CPU module, power module, base, IO module, specification of extension cable and system configuration, EMC standard
XGR redundant series User's Manual	XGR-CPUH/T,CPUH/F user manual describing about XGR CPU module, power module, extension drive, base, IO module, specification of extension cable and system configuration, EMC standard

Currently user manual of FEnet I/F module is written based on the following version.

Related OS version list

Item	OS version
XGK-CPUH, CPUS, CPUA, CPUE, CPUU	V2.0
XGI-CPUU, CPUH, CPUS	V2.0
XG5000	V2.3
XG-PD	V2.3
XGR-CPUH/F, CPUH/T	V1.0

◎ Table of Contents ◎

Chapter 1 Overview	1-1
---------------------------------	------------

Chapter 2 Specifications	2-1 ~ 2-27
---------------------------------------	-------------------

2.1	GENERAL SPECIFICATIONS.....	2-1
2.2	PERFORMANCE SPECIFICATIONS	2-2
2.2.1	Performance specifications	2-2
2.2.2	Pulse input specification	2-4
2.2.3	Preset/Gate input specification.....	2-4
2.2.4	Comparison output specification	2-4
2.3	PART NAMES.....	2-5
2.3.1	Part Names	2-5
2.3.2	Specification of interface with external devices	2-6
2.4	FUNCTIONS	2-9
2.4.1	Pulse input mode	2-9
2.4.2	Counter mode	2-13
2.4.3	Preset	2-16
2.4.4	Compared output.....	2-17
2.4.5	Carry signal	2-21
2.4.6	Borrow signal	2-21
2.4.7	Auxiliary mode.....	2-22

Chapter 3 Installation and Wiring	3-1 ~ 3-5
--	------------------

3.1	INSTALLATION	3-1
3.1.1	Installation environment.....	3-1
3.1.2	Handling precautions	3-1
3.2	WIRING PRECAUTIONS.....	3-1
3.2.1	Example of DC5V voltage output wiring	3-2
3.2.2	Example of DC12V NPN Open Collector output wiring.....	3-3
3.2.3	Example of DC24V PNP Open Collector output wiring	3-4
3.2.4	Example of Line Driver output wiring.....	3-5

Chapter 4 Operation Procedures and Monitoring (XG5000)	4-1 ~ 4-12
---	-------------------

4.1	OPERATION METHOD.....	4-1
4.1.1	Execution of XG5000.....	4-1

4.2	PARAMETERS SETTING.....	4-4
4.2.1	Parameters setting screen	4-4
4.3	MONITORING AND TEST.....	4-6
4.3.1	Monitoring/Test screen	4-6
4.4	REGISTER U DEVICES	4-9
4.4.1	View variables.....	4-9
4.4.2	Register U Devices.....	4-9
4.5	REGISTRATION OF SPECIAL MODULE VARIABLE	4-11
4.5.1	Global/Direct Variables screen	4-11
4.5.2	Registration of the special module variables	4-11

Chapter 5 Internal Memory & I/O Signals 5-1 ~ 5-3

5.1	INTERNAL MEMORY.....	5-1
5.1.1	Configuration of the internal memory.....	5-1
5.1.2	Details & Data configuration	5-2
5.2	I/O SIGNALS.....	5-3

Chapter 6 Global Constant & Global Variable 6-1 ~ 6-4

6.1	GLOBAL CONSTANT.....	6-1
6.1.1	The configuration of Global Constant.....	6-1
6.1.2	The Configuration and Contents of Data	6-2
6.2	GLOBAL VARIABLE.....	6-4

Chapter 7 Programming 7-1 ~ 7-29

7.1	INSTRUCTION AND FUNCTION BLOCK.....	7-1
7.1.1	Instruction of XGK series	7-1
7.1.2	Function Block of XGI/XGR	7-4
7.2	PROGRAM.....	7-8
7.2.1	Count mode setting	7-9
7.2.2	Pulse input mode setting	7-11
7.2.3	Counter check.....	7-12
7.2.4	Preset value setting and enable preset.....	7-13
7.2.5	Enable counter.....	7-14
7.2.6	Carry/borrow detection reset.....	7-14
7.2.7	Auxiliary mode setting and Enable auxiliary function	7-15
7.2.8	Up/down count selection.....	7-21
7.2.9	Use of external preset signal	7-21
7.2.10	Use of external auxiliary function signal.....	7-22
7.2.11	Type of comparison and comparison value setting.....	7-23
7.2.12	Enable comparison, Enable comparison output, Comparison agreement reset	7-25
7.2.13	Comparison output status setting	7-26
7.2.14	Error status and error code.....	7-27

7.2.15 Hold count when power fails	7-28
--	------

Chapter 8 Troubleshooting	8-1 ~ 8-9
--	------------------

8.1 ERROR CODE	8-1
8.2 TROUBLESHOOTING	8-2
8.2.1 LED display status of HS counter module	8-2
8.2.2 Counter status of HS counter module	8-2
8.2.3 Output status of HS counter module	8-2
8.3 TROUBLESHOOTING SEQUENCE.....	8-3
8.3.1 RDY LED Off	8-3
8.3.2 RDY LED Blinks	8-4
8.3.3 Counter operation error	8-5
8.3.4 Counter value error	8-6
8.3.5 Output operation error	8-7
8.3.6 Module status check through XG5000 system monitoring.....	8-8

Appendices	Appendix -1 ~ Appendix -3
-------------------------	----------------------------------

Appendix 1 Terminology	Appendix 1
Appendix 2 Dimensions	Appendix 2
Appendix 3 GM Function Block Conversion Program.....	Appendix 3

Warranty

Chapter 1 Overview

High Speed counter modules were designed for XGT(XGK/XGI/XGR) series and used with XGT PLC CPU.
And XGF-HO2A(Open Collector type) , XGF-HD2A(Line Drive type) modules are available.

High Speed Counter modules can count the high speed pulses which can not be processed by CPU module's counter instructions (CTU, CTD, CTUD etc.), up to binary value of 32 bits (-2,147,483,648 ~ 2,147,483,647).

High Speed counter modules have the following functions;

- 1) 3 kinds of pulse inputs are available.
 - (a) If 1-phase is input
 - (1) Increasing/Decreasing function by means of the applicable program(1-multiplier, 2-multiplier)
 - (2) Increasing/Decreasing function by means of the B-phase input(1-multiplier, 2-multiplier)
 - (b) if 2-phase is input, 1-multiplier, 2-multiplier, 4-multiplier increasing/decreasing function by means of the difference in phase.
 - (c) if CW/CCW is input, increasing/decreasing function by means of A-phase or B-phase.
- 2) Preset/Gate function by means of the applicable program or external input signal
- 3) 6 additional functions are available such as Count Clear, Count Latch, Sampling Count, Input frequency Measure, Revolution Measure per unit time and Count Disable.
- 4) 7 kinds of compared signals can be outputted at output contact of the built-in transistor through compared based value (Min compared value, Max compared value) and current count value.

Chapter 2 Specifications

2.1 General Specifications

General specifications of XGT series

No.	Item	Specification	Related specifications		
1	Operating temperature	0°C ~ +55°C	-		
2	Storage temperature	-25°C ~ +70°C	-		
3	Operating humidity	5~95%RH, Non-condensing	-		
4	Storage humidity	5~95%RH, Non-condensing	-		
5	Vibration	For discontinuous vibration		Each 10 times in X,Y,Z directions IEC61131-2	
		Frequency	Acceleration		Amplitude
		10≤f< 57Hz	-		0.075mm
		57≤f≤150Hz	9.8m/s ² (1G)		-
		For continuous vibration			
		Frequency	Acceleration		Amplitude
		10≤f< 57Hz	-		0.035mm
57≤f≤150Hz	4.9m/s ² (0.5G)	-			
6	Shocks	* Maximum impact acceleration:147m/s ² (15G) * Authorized time :11ms * Pulse wave : Signal half-wave pulse (Each 3 times in X,Y,Z directions)	IEC61131-2		
7	Impulse Noise	Square wave impulse noise	±1,500V	Test specifications of LS Industrial Systems	
		Electrostatic discharging	Voltage : 4kV (contact discharging)	IEC 61131-2, IEC 61000-4-2	
		Radiated electromagnetic field noise	27 ~ 500MHz, 10 V/m	IEC 61131-2, IEC 61000-4-3	
		Fast Transient / burst noise	Class Voltage	Power module 2kV	Digital/ Analog I/O communication interface 1kV
8	Ambient conditions	No corrosive gas or dust	-		
9	Operating height	2,000m or less	-		
10	Pollution degree	2 or less	-		
11	Cooling type	Natural air cooling	-		

Notes

- 1) IEC(International Electrotechnical Commission):
An international nongovernmental organization which promotes internationally cooperated standardization in electric/electronic fields, publishes international standards and manages applicable estimation system related with.
- 2) Pollution degree:
An index indicating pollution level of the operating environment which decides insulation performance of the devices. For instance, Pollution level 2 indicates the state generally that only non-conductive pollution occurs. However, this state contains temporary conduction due to dew produced.

Chapter 2 Specifications

2.2 Performance Specifications

Specifications of High Speed counter module's basic performance, preset/gate input and transistor output are as described below.

2.2.1 Performance specifications

Item		Specification	
		XGF-H02A	XGF-HD2A
Count Input signal	Signal	A-phase, B-phase	
	Input type	Voltage input (Open Collector)	Differential input (Line Drive):
	Signal level	DC 5/12/24V	RS-422A Line Drive /HTL LEVEL Line Drive
Maximum coefficient speed		200kpps	500kpps (HTL input is 250kpps)
Number of channels		2	
Coefficient range		Signed 32-bit (-2,147,483,648 ~ 2,147,483,647)	
Count mode (program setting)		Linear Count (if 32-bit range exceeded, Carry/Borrow occurs, the maximum/minimum count value displayed)	
		Ring Count (repeated count within setting range)	
Input mode (program setting)		1-phase input	
		2-phase input	
		CW/CCW input	
Up/down Setting	1-phase input	Increasing/decreasing operation setting by B-phase input	
		Increasing/decreasing operation setting by program	
	2-phase input	Automatic setting by difference in phase	
	CW/CCW	A-phase input: increasing operation	
B-phase input: decreasing operation			
Multiplication function	1-phase input	1/2 multiplication (program setting)	
	2-phase input	1/2/4 multiplication (program setting)	
	CW/CCW	1-multiplication	
Control input	Signal	Preset instruction input, auxiliary mode instruction input	
	Signal level	DC 5V/12V/24V (by terminal selection) input type	
	Signal type	Voltage	
External output	Output points	2-point/channel (for each channel): terminal output available	
	Type	Select single-compared (>, >=, =, <=, <) or section compared output (included or excluded) (program setting)	
	Output type	Open collector output (Sink)	

Notes

In XGR system, you can use HSC module only at extension base. You can't equip HSC module at basic base.

2.2.2 Pulse input specification

Item	Specification			Line driver
	Open collector			
Input volatage	DC 24V (17.0V~26.4V)	DC 12V (9.8V~13.2V)	DC 5V (4.5V~5.5V)	RS-422A line driver (5V level)/HTL line Driver(24V level)
Input current	7mA~11mA	7mA~11mA	7mA~11mA	
Min. On guaranteed voltage	17.0V	9.8V	4.1V	
Max. Off guaranteed voltage	4.5V	3.0V	1.7V	

2.2.3 Preset, auxiliary function input specification

Item	Specification		
	DC 24V (17.0V~26.4V)	DC 12V (9.8V~13.2V)	DC 5V (4.5V~5.5V)
Input current	7mA~11mA	7mA~11mA	7mA~11mA
Min. On guaranteed voltage	17.0V	9.8V	4.1V
Max. Off guaranteed voltage	4.5V	3.0V	1.7V
On delay time	1 ms or less		
Off delay time	1 ms or less		

2.2.4 Comp. output specification

Item	Specification
Output type	Transistor sink
Rated output	DC 24V, 100 mA/point
Leakage current	0.1 mA or less
Saturated area voltage	1.3 V or less
On delay time	0.1 ms or less
Off delay time	0.1 ms or less

2.3 Part Names

2.3.1 Part Names

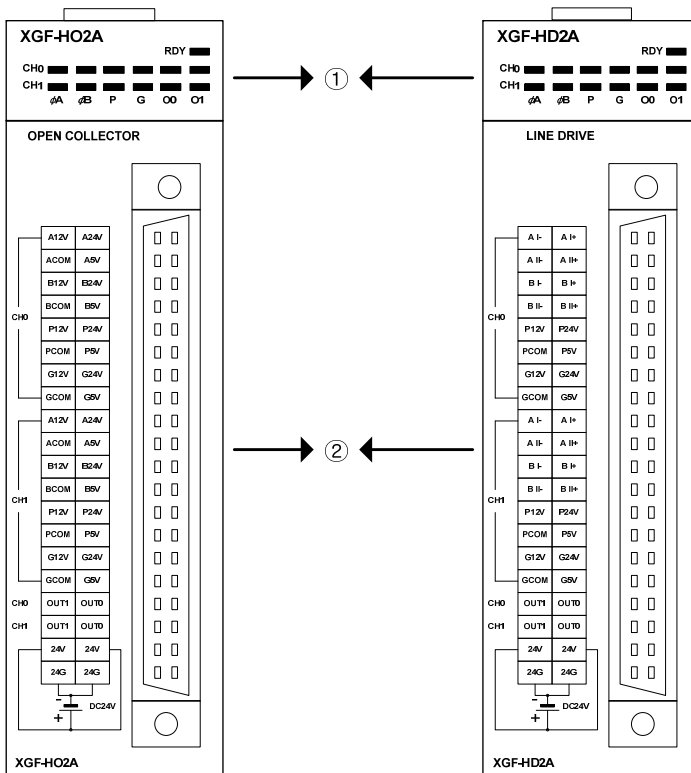

No.	Name	Contents
①	Run LED (ΦA, ΦB, P, G, OO, O1)	On: relevant channel pulse inputting, Preset/Auxiliary function signal inputting, Comparison outputting Off: No input of relevant channel pulse, No input of preset/auxiliary function signal, No output of comparison
	Ready signal (RDY)	On: HSC module normal Off: Power off or CPU module reset, HSC module error Flicker: HSC module error
②	External wiring connector	Connector to connect with external I/O

2.3.2 Specification of interface with external devices

1. Arrangement of connector pins

(1) XGF-HO2A

Pin arrangement	Pin No.		Signal name	
	CH0	CH1		
	1	17	A12V	A phase pulse input 12V
	2	18	A24V	A phase pulse input 24V
	3	19	ACOM	A phase pulse input COM
	4	20	A5V	A phase pulse input 5V
	5	21	B12V	B phase pulse input 12V
	6	22	B24V	B phase pulse input 24V
	7	23	BCOM	B phase pulse input COM
	8	24	B5V	B phase pulse input 5V
	9	25	P12V	Preset input 12V
	10	26	P24V	Preset input 24V
	11	27	PCOM	Preset input COM
	12	28	P5V	Preset input 5V
	13	29	G12V	Auxiliary function input 12V
	14	30	G24V	Auxiliary function input 24V
	15	31	GCOM	Auxiliary function input COM
	16	32	G5V	Auxiliary function input 5V
	33	35	OUT1	Comp. output 1
	34	36	OUT0	Comp. output 0
	37	38	24V	External power input 24V
	39	40	24G	External power input GND

(2) XGF-HD2A

Pin arrangement	Pin No.		Signal name	
	CH0	CH1		
	1	17	A I -	A I phase differentiation input -
	2	18	A I +	A I phase differentiation input +
	3	19	A II -	A II phase differentiation input -
	4	20	A II +	A II phase differentiation input +
	5	21	B I -	B I phase differentiation input -
	6	22	B I +	B I phase differentiation input +
	7	23	B II -	B II phase differentiation input -
	8	24	B II +	B II phase differentiation input +
	9	25	P12V	Preset input 12V
	10	26	P24V	Preset input 24V
	11	27	PCOM	Preset input COM
	12	28	P5V	Preset input 5V
	13	29	G12V	Auxiliary function input 12V
	14	30	G24V	Auxiliary function input 24V
	15	31	GCOM	Auxiliary function input COM
	16	32	G5V	Auxiliary function input 5V
	33	35	OUT1	Comp. output 1
	34	36	OUT0	Comp. output 0
	37	38	24V	External power input 24V
	39	40	24G	External power input GND

Chapter 2 Specifications

2. Internal circuit

Describes internal circuit of HSC module to connect HSC module with external device

(1) XGF-HO2A

I/O	Internal circuit	No.	Terminal	Pin No.		Signal name
				CH0	CH1	
Input		①	A24V	2	18	A phase pulse input 24V
		②	A12V	1	17	A phase pulse input 12V
		③	A5V	4	20	A phase pulse input 5V
		④	ACOM	3	19	A phase pulse input COM
		①	B24V	6	22	B phase pulse input 24V
		②	B12V	5	21	B phase pulse input 12V
		③	B5V	8	24	B phase pulse input 5V
		④	BCOM	7	23	B phase pulse input COM
		⑤	P24V	10	26	Preset input 24V
		⑥	P12V	9	25	Preset input 12V
		⑦	P5V	12	28	Preset input 5V
		⑧	PCOM	11	27	Preset input COM
		⑤	G24V	14	30	Auxiliary function input 24V
		⑥	G12V	13	29	Auxiliary function input 12V
		⑦	G5V	16	32	Auxiliary function input 5V
		⑧	GCOM	15	31	Auxiliary function input COM
Output		⑨	OUT0	34	36	Comp. output 0
		⑩	OUT1	33	35	Comp. output 1
		⑪	24V	37	38	External power input 24V
		⑫	24G	39	40	External power input GND

Notes

External power (24V: 37, 38, 24G: 39, 40) is power source to output comparison output to terminal (33, 34, 35, 36). Connect when using comparison output.

(2) XGF-HD2A

I/O	Internal circuit	No.	Terminal	Pin. No.		Signal
				CH0	CH1	
Input		①	AI+	2	18	A I phase differentiation input +
		②	AI+	4	20	A II phase differentiation input +
		③	AI-	1	17	A I phase differentiation input -
		④	AI-	3	19	A II phase differentiation input -
		①	BI+	6	22	B I phase differentiation input +
		②	BI+	8	24	B II phase differentiation input +
		③	BI-	5	21	B I phase differentiation input -
		④	BI-	7	23	B II phase differentiation input -
		⑤	P24V	10	26	Preset input 24V
		⑥	P12V	9	25	Preset input 12V
		⑦	P5V	12	28	Preset input 5V
		⑧	PCOM	11	27	Preset input COM
⑤		G24V	14	30	Auxiliary function input 24V	
⑥		G12V	13	29	Auxiliary function input 12V	
⑦		G5V	16	32	Auxiliary function input 5V	
⑧		GCOM	15	31	Auxiliary function input COM	
Output		⑨	OUT0	34	36	Comp. output 0
		⑩	OUT1	33	35	Comp. output 1
		⑪	24V	37	38	External power input 24V
		⑫	24G	39	40	External power input GND

Notes

- (1) AI+, AI-, BI+, BI- are line driver input terminal of 5V level
- (2) AII+, AII-, BII+, BII- are line driver input terminal of 24V level.

2.4 Function

2.4.1 Input pulse type

1. 1 phase input

(1) Up/Down operation by program setting

(a) 1 phase 1 input 1 multiplication input

When input pulse of A phase is rising, count operates and up/down count operation is set by program

Up/Down count classification	A phase pulse rising	A phase pulse falling
Up/Down count setting Off	Up count (+1)	-
Up/Down count setting On	Down count (-1)	-

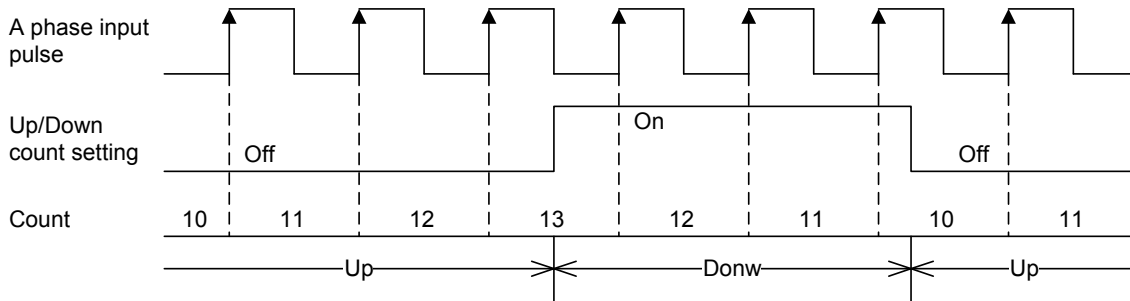

(b) 1 phase 1 input 2 multiplication input

When input pulse of A phase is rising and falling, count operates and up/down count operation is set by program

Up/Down count classification	A phase pulse rising	A phase pulse falling
Up/Down count setting Off	Up count (+1)	Up count (+1)
Up/Down count setting On	Down count (-1)	Down count (-1)

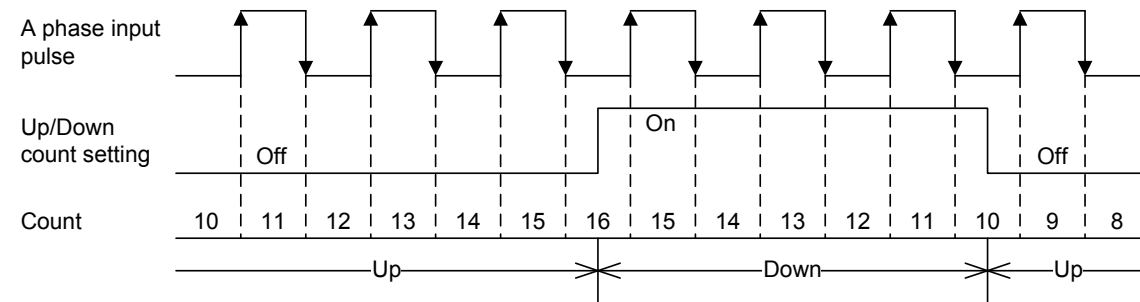

(2) Up/Down count operation by B phase input signal

(a) 1 phase 2 input 1 multiplication input

When input pulse of A phase is rising, count operates and up/down count operation is set by level of B phase input pulse.

Up/Down count classification	A phase pulse rising	A phase pulse falling
B phase input pulse Off	Up count (+1)	-
B phase input pulse On	Down count (-1)	-

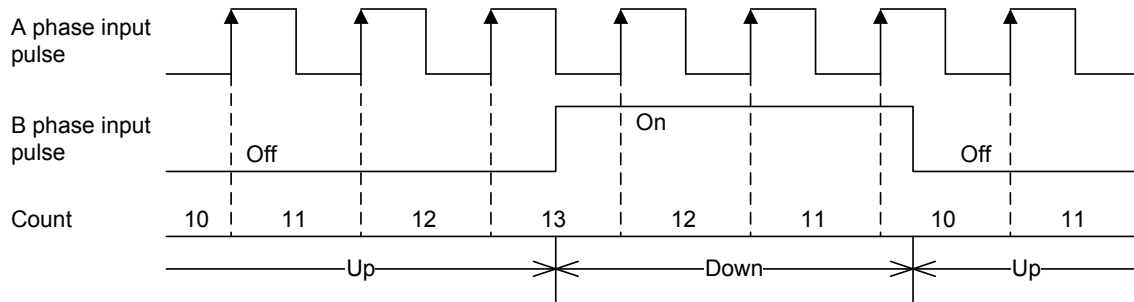

(b) 1 phase 2 input 2 multiplication input

When input pulse of A phase is rising and falling, count operates and up/down count operation is set by level of B phase input pulse.

Up/Down count classification	A phase pulse rising	A phase pulse falling
B phase input pulse Off	Up count (+1)	Up count (+1)
B phase input pulse On	Down count (-1)	Down count (-1)

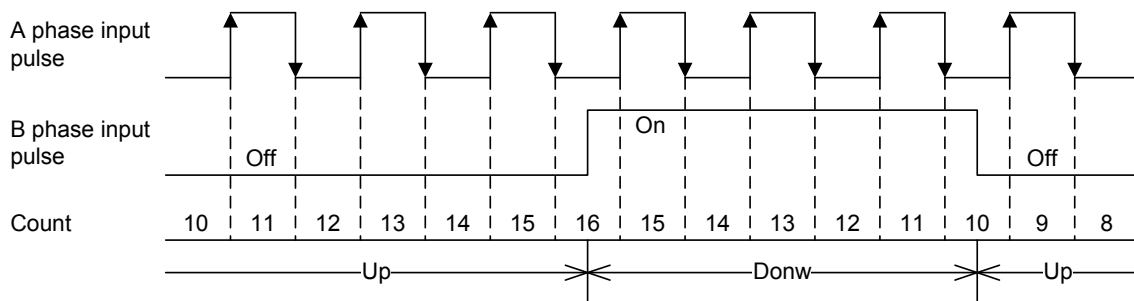

Chapter 2 Specifications

2. 2 phase input

(1) 2 phase 1 multiplication input

When input pulse of A phase is ahead of B phase input pulse, at rising edge of A phase input pulse, Up count is operated.

When input pulse of B phase is ahead of A phase input pulse, at rising edge of A phase input pulse, Down count is operated.

Up/Down count classification	A phase pulse rising	A phase pulse falling
Phase of A and B (A-B)	Up count (+1)	-
Phase of A and B (B-A)	-	Down count (-1)

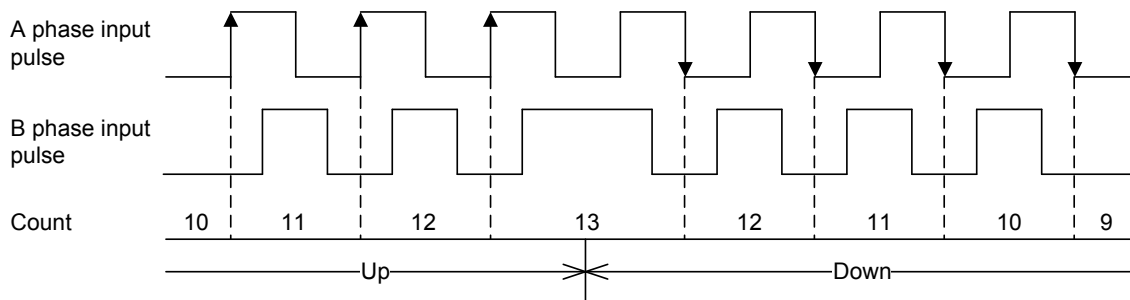

(2) 2 phase 2 multiplication input

When input pulse of A phase is ahead of B phase input pulse, at rising and falling edge of A phase input pulse, Up count is operated.

When input pulse of B phase is ahead of A phase input pulse, at rising and falling edge of A phase input pulse, Down count is operated.

Up/Down count classification	A phase pulse rising	A phase pulse falling
Phase of A and B (A-B)	Up count (+1)	Up count (+1)
Phase of A and B (B-A)	Down count (-1)	Down count (-1)

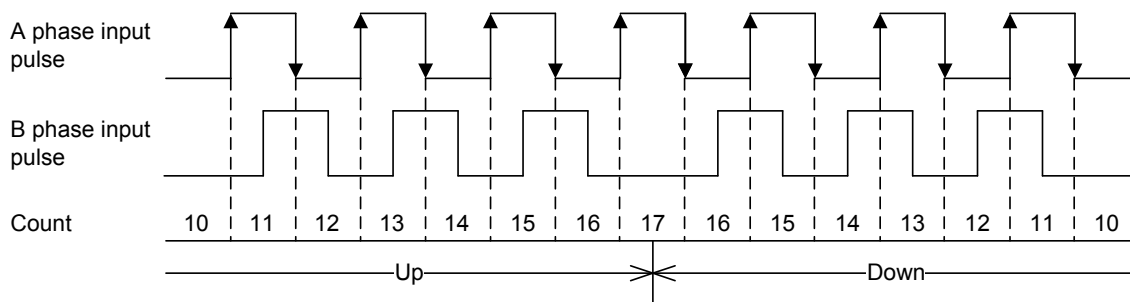

(3) 2 phase 4 multiplication input

When input pulse of A phase is ahead of B phase input pulse, at rising and falling edge of A and B phase input pulse, Up count is operated.

When input pulse of B phase is ahead of A phase input pulse, at rising and falling edge of A and B phase input pulse, Up count is operated.

Up/Down count classification	A phase pulse rising	A phase pulse falling	A phase pulse rising	A phase pulse falling
Phase of A and B (A-B)	Up count (+1)	Up count (+1)	Up count (+1)	Up count (+1)
Phase of A and B (B-A)	Down count (-1)	Down count (-1)	Down count (-1)	Down count (-1)

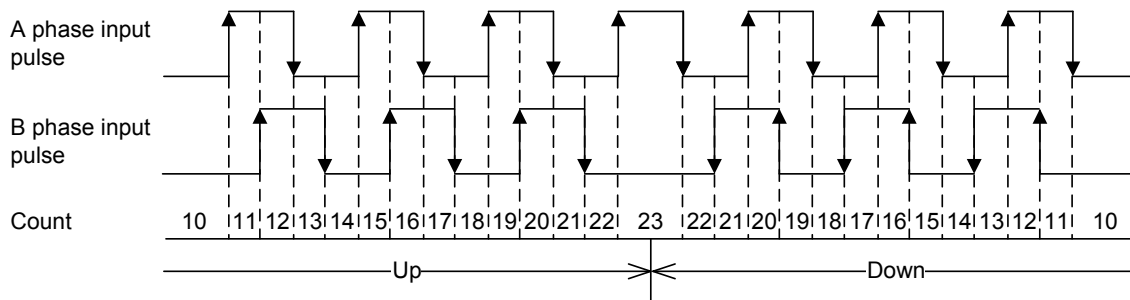

3. CWCCW(ClockWise/Counter ClockWise) input

Count is operated at rising edge of A phase input pulse or B phase input pulse and Up/Down count operation is determined by level of A or B input pulse

Up/Down count classification	A phase pulse rising	A phase pulse falling	B phase pulse rising	B phase pulse falling
B phase input pulse Off	Up count (+1)	-	-	-
A phase input pulse Off	-	-	Down count (-1)	-

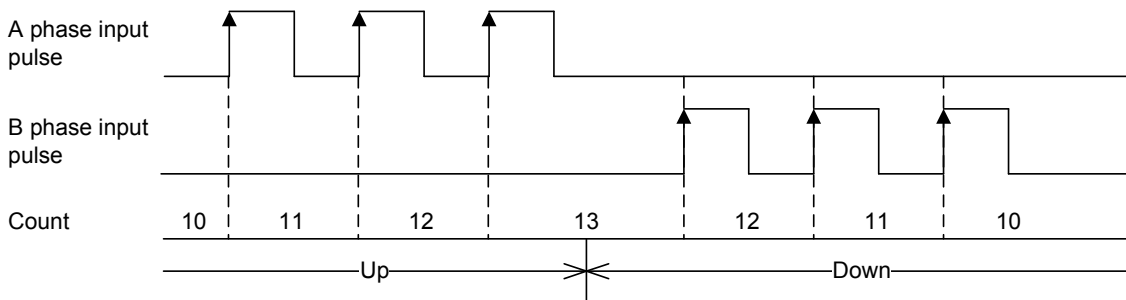

2.4.2 Count type

1. Linear count

(1) Linear Count range: -2,147,483,648 ~ 2,147,483,647

(2) Up count

If count value reaches the maximum value while increased, Carry will occur, and Carry occurs, count stops and increasing is not available but decreasing is available.

(3) Down count

If count value reaches the minimum value while decreased, Borrow will occur and Borrow occurs, count stops and decreasing is not available but increasing is available

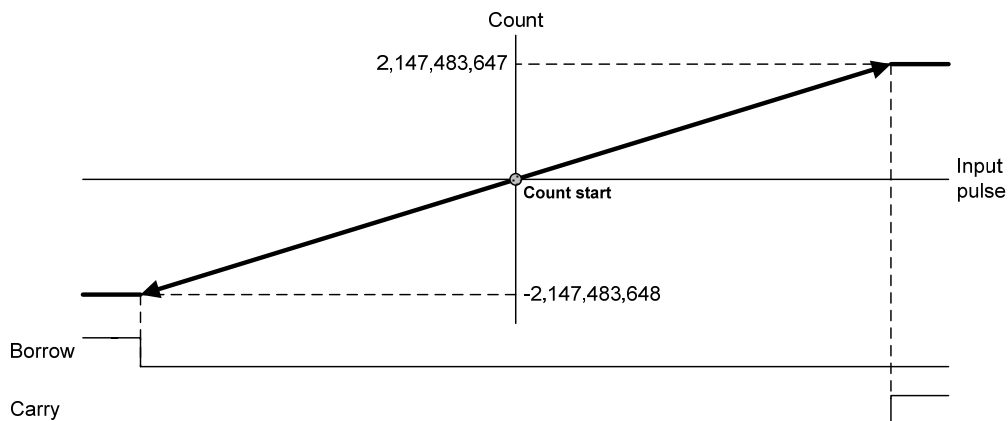

2. Ring count

(1) Count operation is executed within the user defined range repeatedly.

(2) Ring Count range: ring count min. value ~ ring count max. value

(3) Ring count display

If Ring Counted, minimum value of Ring Count is displayed as count, but the maximum value is not displayed as count.

(4) Ring count operation

(a) ring count min. value \leq Current count \leq ring count max. value

1) Up count

If count value exceeds maximum value during increasing count, Carry only occurs and count is executed starting from min. value

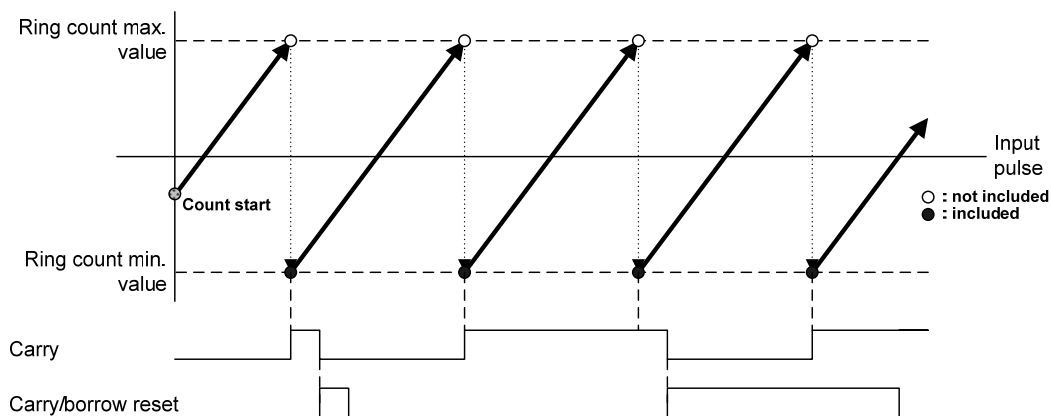

2) Down count

If count value reaches minimum value during decreasing count, Borrow only occurs and count is executed starting from max. value

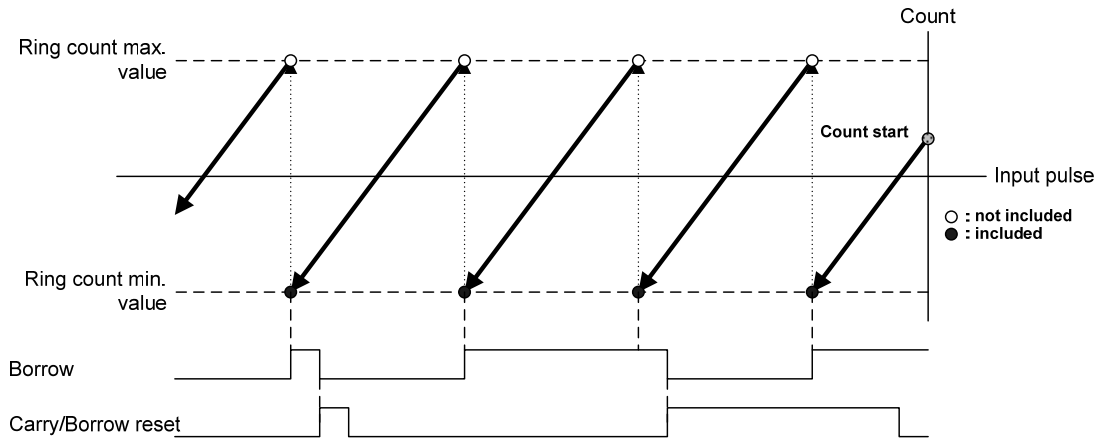

(b) $-2,147,483,648 \leq \text{current count} < \text{ring count min. value}$ or $\text{ring count max. value} < \text{current count} \leq 2,147,483,647$

1) Up count

If count reaches ring count max. value, it changes into ring count min value and carry occurs and count is executed until 2,147,483,647. If count exceeds 2,147,483,647, count is changed into -2,147,483,648 and executed repeatedly.

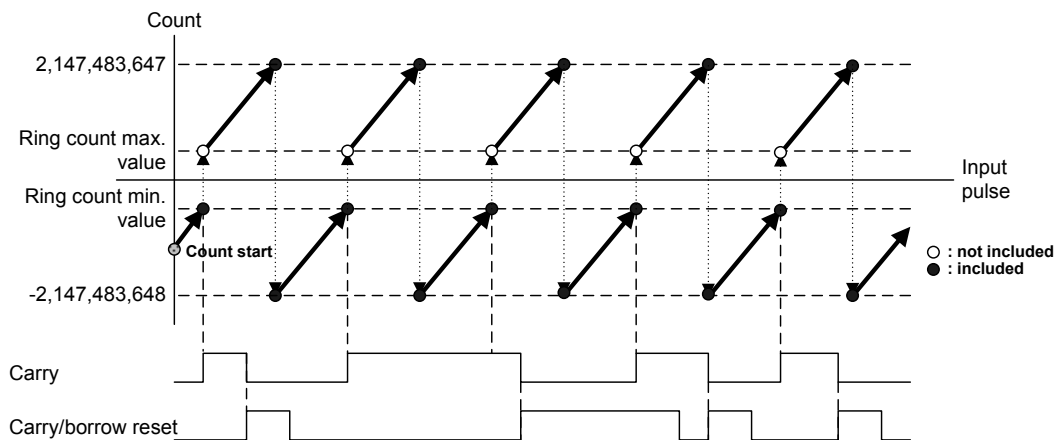

Chapter 2 Specifications

2) Down count

If count reaches min. value, borrow occurs and count is changed into ring count max. value. Count is executed until 2,147,483,647. If count reaches -2,147,483,648, count is changed into 2,147,483,648 and executed again.

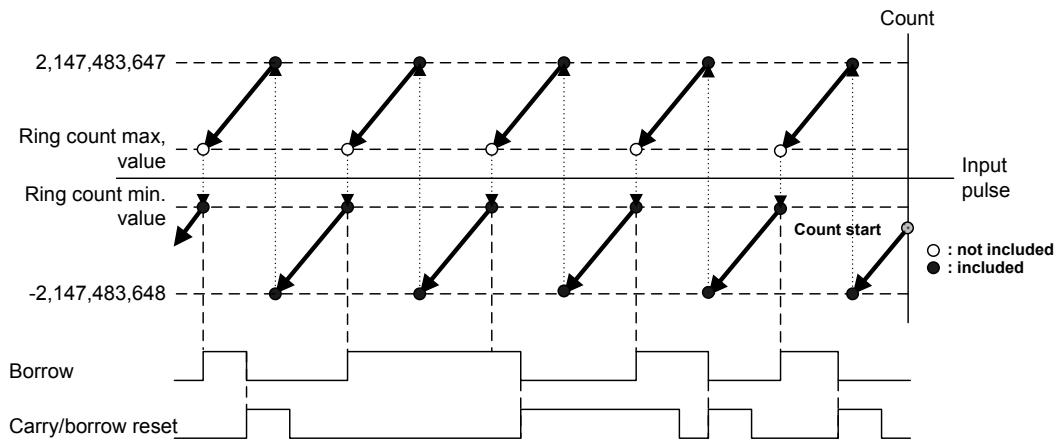

Notes

When setting ring count max/min value, if current count is out of range of ring count, module assumes that that is mistake of user and LED flickers and error occurs. If the user executes preset operation and changes the current count to be within ring count range, LED is off and error disappears.

2.4.3 Preset

(1) When Enable Preset is On, current count is changed into preset setting value. Only with setting of preset, current count is not changed and you have to execute the Enable Preset of change the current count.

(2) Operation method

Setting preset value -> Enable Preset On

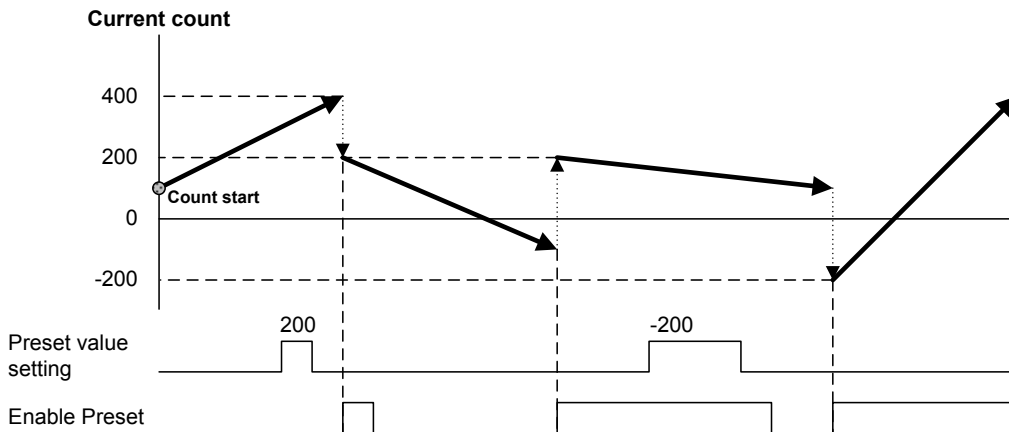

Notes

- (1) To use preset function by external input signal, set Enable Preset as 1 (on), turn on external preset input signal.
- (2) If you execute the preset by external input signal, external preset detection becomes 1 (On). When external preset detection is 1 (on), external preset is not executed. In order to change external preset detection as 0 (Off), turn on external preset detection reset..

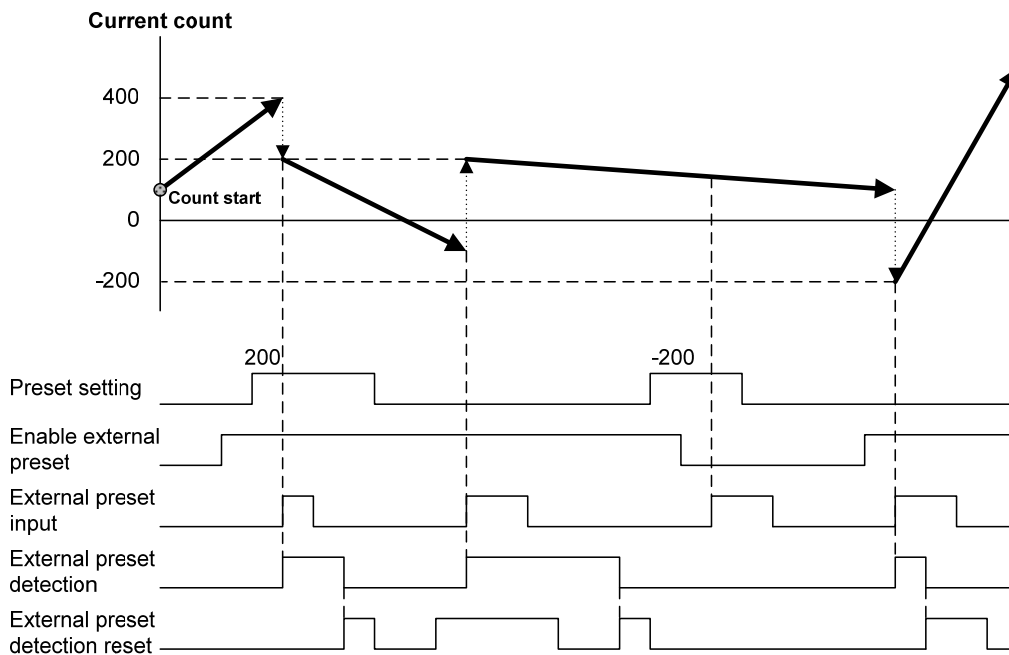

2.4.4 Compared output

- (1) High Speed counter module has a compared output function used to compare present count value with compared value in size to output as compared.
- (2) Available compared outputs are 2 for 1 channel, which can be used separately.
- (3) Compared output conditions are 7 associated with $<$, \leq , $=$, \geq , $>$, $\leq\leq$, $\geq\geq$
- (4) In order to make actual comparison enabled after compared output condition set, the compared enable signal is to be On, at this time, output is displayed only on program (U device or Global variable), and in order to send out the actual external output with LED turned On, the output enable signal is to be On.

1. Preset value $<$ Compared value

If counted present value is less than compared value, output is sent out, and if present value increases to be equal to or greater than compared value, output is not sent out.

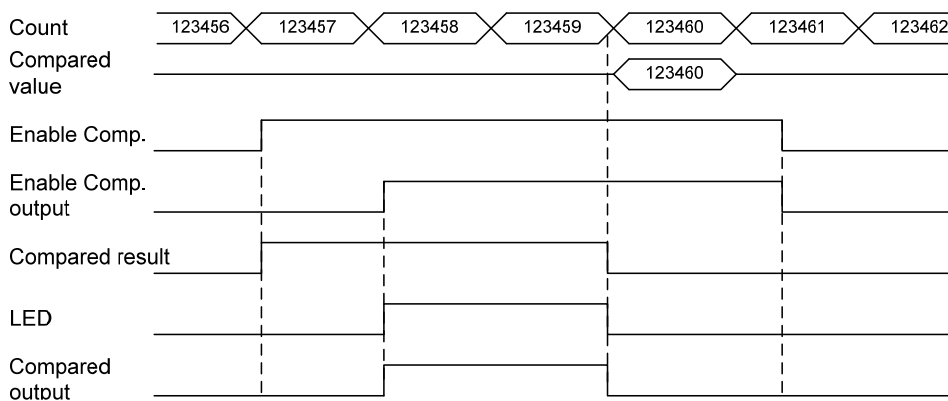

Notes

- (1) Compared result can be checked at U device for XGK, Global variable for XGI/XGR
- (2) Compared output is a signal to be output at external terminal (33, 34, 35, 36).

2. Count value \leq Compared value

If present count value is less than or equal to compared value, output is sent out, and if count value increases to be greater than compared value, output is not sent out.

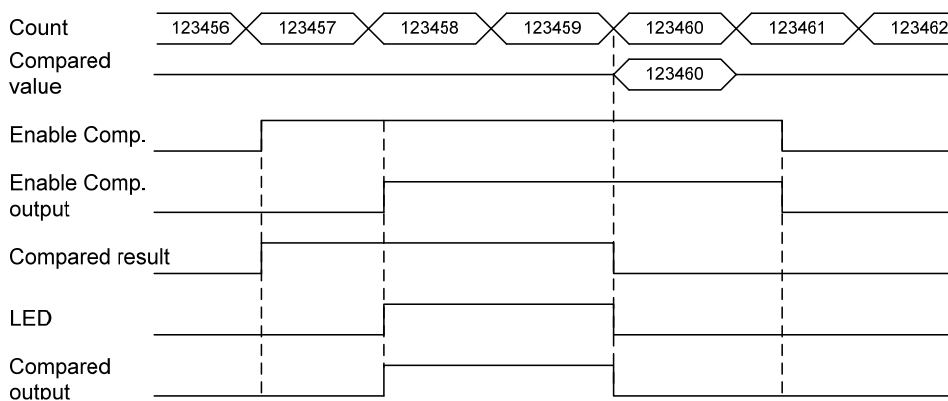

3. Count value = Compared value

If present count value is equal to compared value, output is sent out, and even if count value increases to be greater or less than compared value, output is kept On. In order to turn the output Off, identical reset signal is to be On.

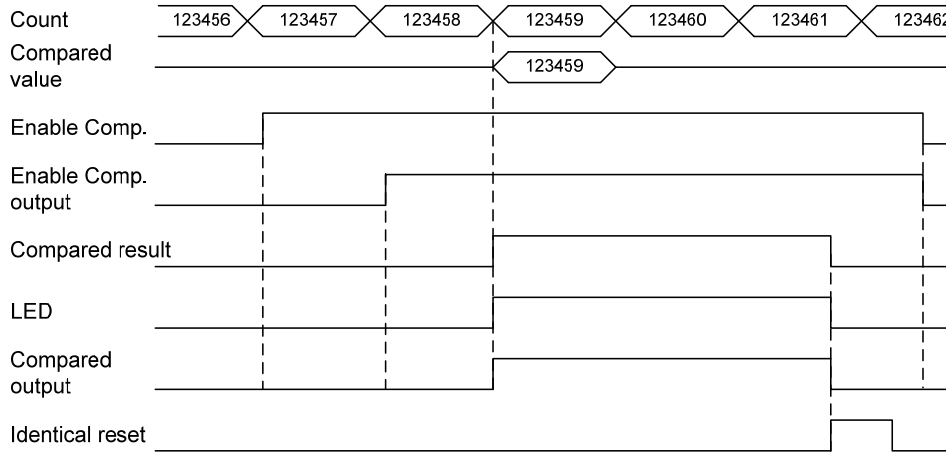

4. Count value \geq Compared value

If present count value is greater than or equal to compared value, output is sent out, and if count value decreases to be less than compared value, output is not sent out.

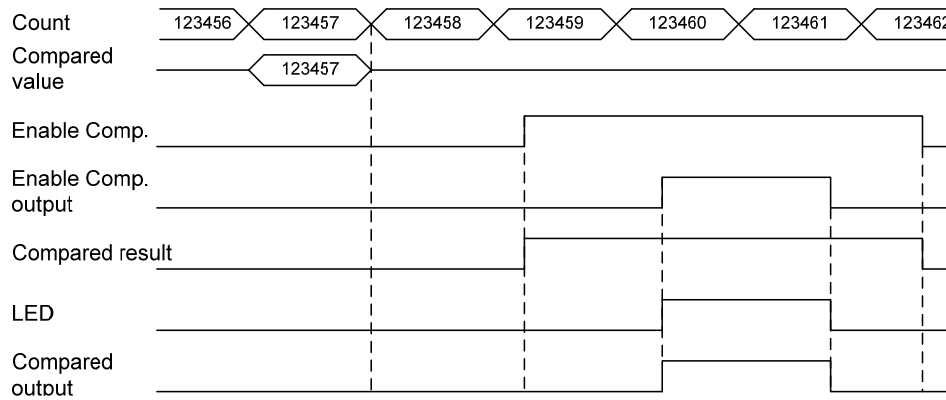

Chapter 2 Specifications

5. Count value > Compared value

If present count value is greater than compared value, output is sent out, and if count value decreases to be less than or equal to compared value, output is not sent out.

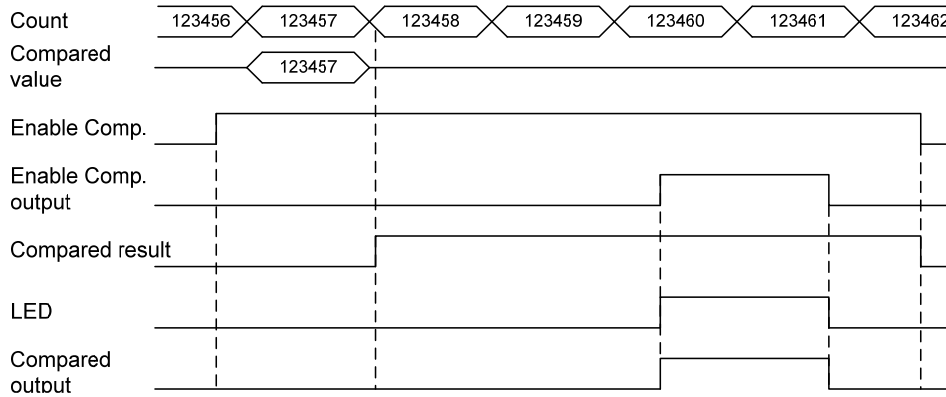

6. Compared value min. ≤ Count value ≤ Compared value max.

If present count value is greater than or equal to compared value 1 and less than or equal to compared value 2, output is sent out, and if count value increases/decreases to exceed compared value's range, output is not sent out.

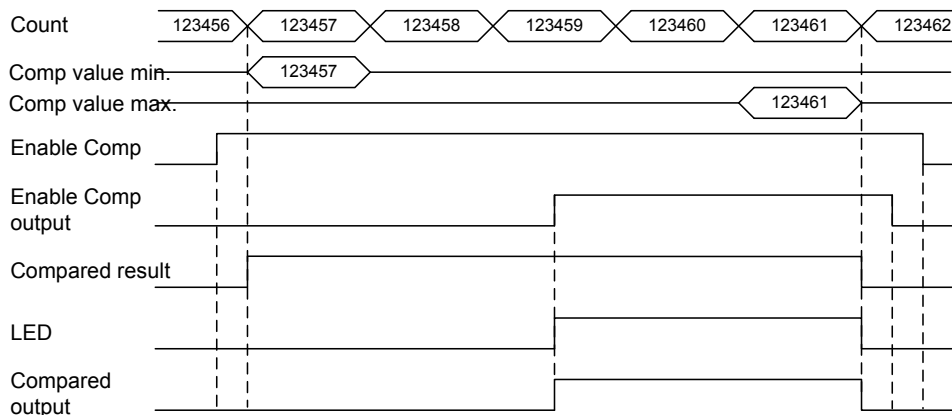

7. Count value \leq Compared value min., Count value \geq Compared value max.

If present count value is less than or equal to compared value 1 and greater than or equal to compared value 2, output is sent out, and if count value increases/decreases to exceed compared value's range, output is not sent out.

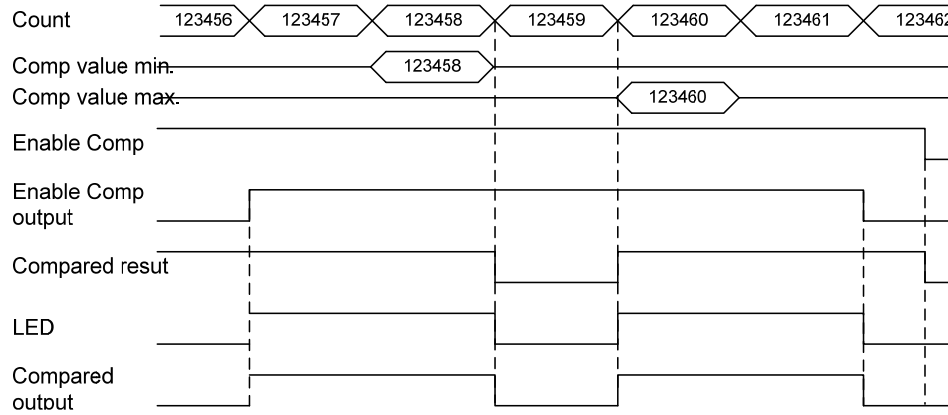

2.4.5 Carry

1. Carry Signal occurs
 - (1) When count range maximum value of 2,147,483,647 is reached during Linear Count.
 - (2) When maximum value of Ring Count changed to the minimum value during Ring Count.

2. Count when Carry Signal occurs
 - (1) Count stops if Carry occurs during Linear Count.
 - (2) Count does not stop even if Carry occurs during Ring Count.

3. Carry reset

The Carry generated can be cancelled by Carry/Borrow reset signal On.

2.4.6 Borrow

1. Borrow signal occurs
 - (1) When count range minimum value of -2,147,483,648 is reached during Linear Count.
 - (2) When minimum value of Ring Count changed to the maximum value during Ring Count user-defined Ring Count minimum value maximum value.

2. Count when Borrow signal occurs
 - (1) Count stops if Borrow occurs during Linear Count.
 - (2) Count does not stop even if Borrow occurs during Ring Count..

3. Borrow reset

The Borrow generated can be cancelled by Carry/Borrow reset signal On.

2.4.7 Auxiliary mode

High Speed counter module provides 6 auxiliary modes as well as basic count function and compared output function. In order to use the auxiliary modes, auxiliary mode enable signal is to be "On".

Notes

- (1) To use auxiliary function by program, turn off the external auxiliary mode and turn on Enable Auxiliary
- (2) To use auxiliary function by an external signal, turn on the external auxiliary mode and turn on External auxiliary input signal (GATE).

1. Count clear

- (1) When Auxiliary Mode enable signal is On, present count value is set to 0.
- (2) Setting method
Set auxiliary mode setting mode to 1 -> Auxiliary mode enable signal On.

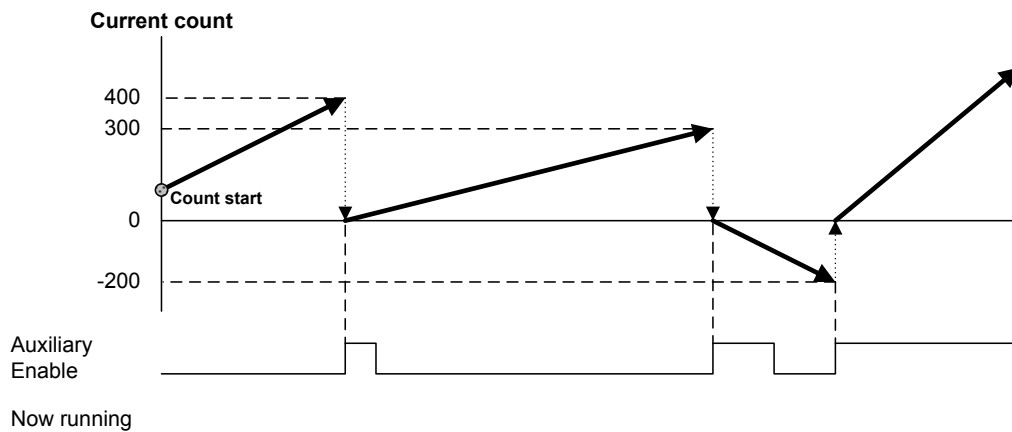

Chapter 2 Specifications

2. Count Latch

(1) When auxiliary mode enable signal is On, present count value is latched

(2) Setting method

Set auxiliary mode setting mode to 2 -> Auxiliary mode enable signal On

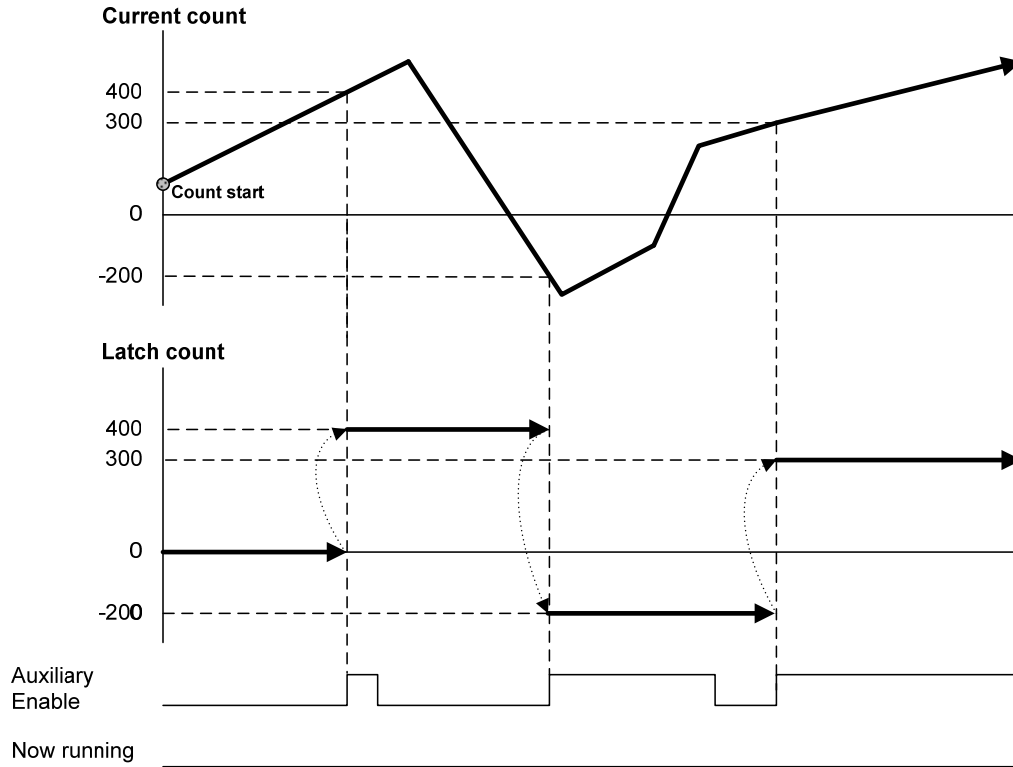

3. Sampling Count

(1) When auxiliary mode enable signal is On, it counts for a specified time.

(2) Setting method

Set auxiliary mode setting mode to 3 -> Time setting -> Auxiliary mode enable signal On

(3) Display during auxiliary mode operation

Sampling Count function operates for a specified time when auxiliary mode enable signal is On, and the auxiliary mode in progress signal is On at the same time.

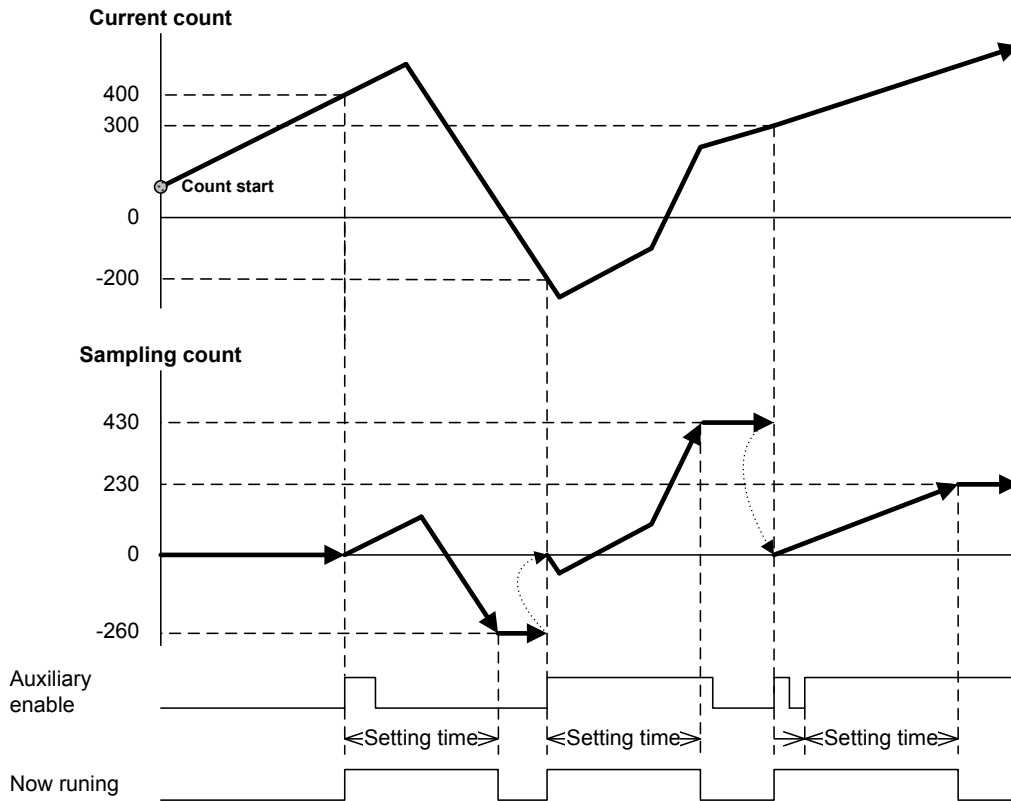

Chapter 2 Specifications

4. Input Frequency Measure

- (1) While auxiliary mode enable signal is On, it indicates frequency of input pulse. Unit of input frequency conforms to setting of frequency unit.
- (2) Setting method
Set auxiliary mode setting mode to 4 -> Set frequency unit -> Auxiliary mode enable signal On.
- (3) Frequency input mode can be specified as below, whose update cycle and resolution will be decided based on the applicable mode.

Frequency unit setting	Unit [Hz]	Updated cycle [ms]
0	1	1000
1	10	100
2	100	10
3	1000	1

(4) Display during auxiliary mode operation

While auxiliary mode enable signal is On, Now Running signal is on

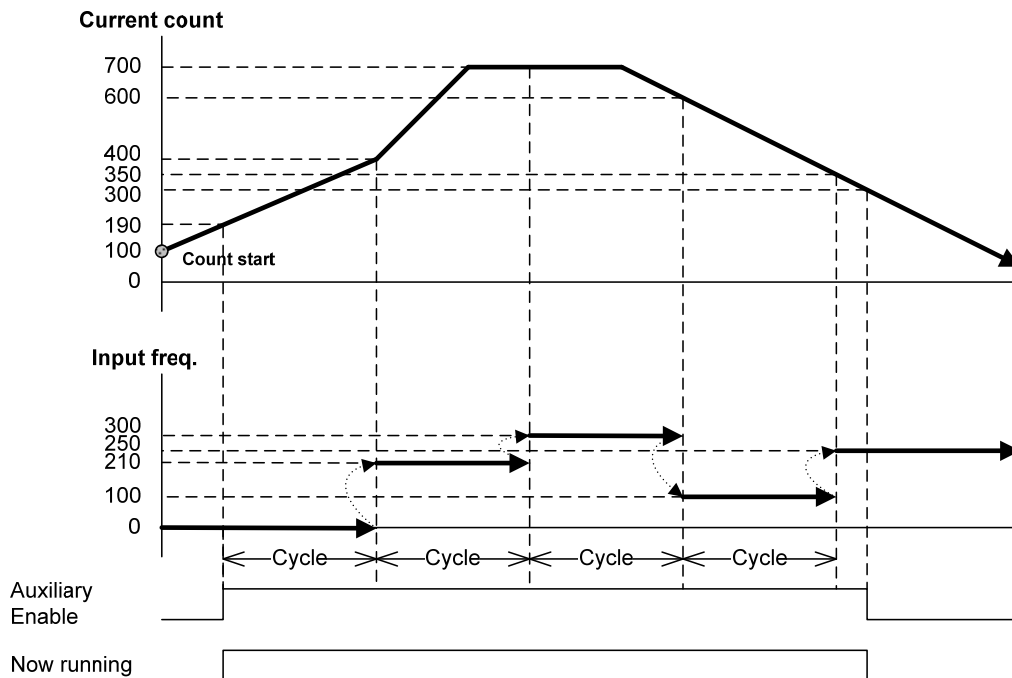

※ On the figure, unit is 1Hz and updated cycle is 1000msec.

5. Revolution/Unit time

(1) While auxiliary mode enable signal is On, it calculates the number of input pulses for a specified time and indicates the revolution/unit time. To use this function, setting time and No. of pulse/revolution should be set.

(2) Setting method

Set auxiliary mode setting mode to 5 setting -> Time setting, No. of pulse/revolution -> Auxiliary mode enable signal On.

(3) With the number of pulses per revolution input and time set to 1 minute (60000ms), the value of RPM is displayed.

(4) Display during auxiliary mode operation

While auxiliary mode enable signal is On, Now Running signal is on

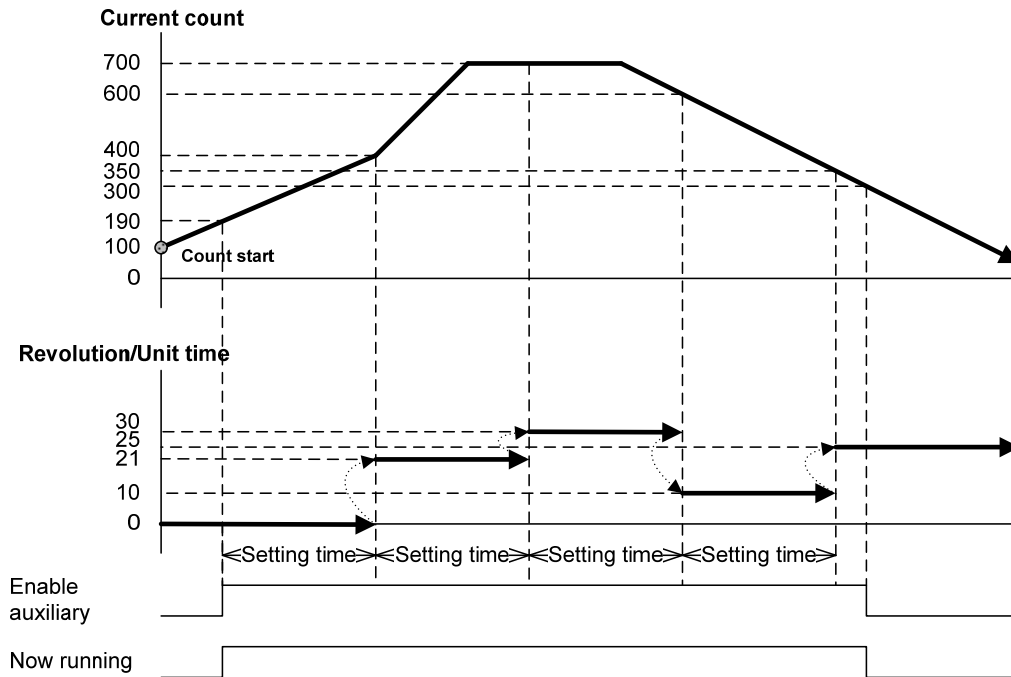

※ On the figure, the number of pulse/revolution is set to be 10.

Chapter 2 Specifications

6. Count Disable

(1) While auxiliary mode enable signal is On, count operation stops.

(2) Setting method

Set auxiliary mode setting mode to 6 -> Auxiliary mode enable signal On

(3) Display during auxiliary mode operation

While auxiliary mode enable signal is On, Now Running signal is on

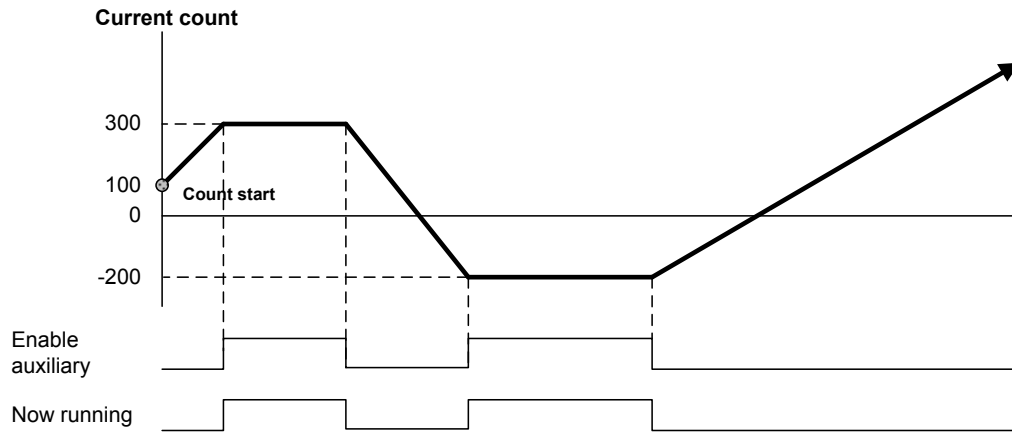

Chapter 3 Installation and Wiring

3.1 Installation

3.1.1 Installation environment

This product is of high reliance regardless of installation environment. However, for the sake of reliance and stability of the system, please pay attention to those precautions described below.

1) Environmental conditions

- To be installed on the control panel waterproof and dustproof.
- No continuous shocks or vibration will be expected.
- Not to be exposed to the direct sunlight.
- No dew should be caused by rapid temperature change.
- Ambient temperature should be kept 0 - 55°C.

2) Installation work

- No wiring waste is allowed inside PLC when wiring or drilling screw holes.
- To be installed on a good location to work on.
- Don't let it installed on the same panel as a high-voltage device is on.

3.1.2 Handling precautions

Precautions for handling High Speed counter module are as described below from the opening to the installation.

- 1) Don't let it dropped or shocked hard.
- 2) Don't remove PCB from the case. It will cause abnormal operation
- 3) Don't let any foreign materials including wiring waste inside the top of the module when wiring.
Remove foreign materials if any inside.
- 4) Don't install or remove the module while powered On.

3.2 Wiring Precautions

- 1) Pay attention to do action about external noise during wiring for the pulse input of the high counter module.
- 2) Surely use twisted pair shielded cable, grounded with 3 class applied.
- 3) Keep away from power cable or I/O line which may cause noise.
- 4) Connect A-phase only for 1-phase input.
- 5) Please take the wiring with consideration the maximum output distance of pulse generator.

3.2.1 Example of DC5V voltage output wiring

- If the pulse generator is voltage output type, example of wiring with HSC is as shown below;
- The wiring will be the same if the pulse generator (Encoder or Manual pulse generator) of voltage output type is used through Totem Pole output.

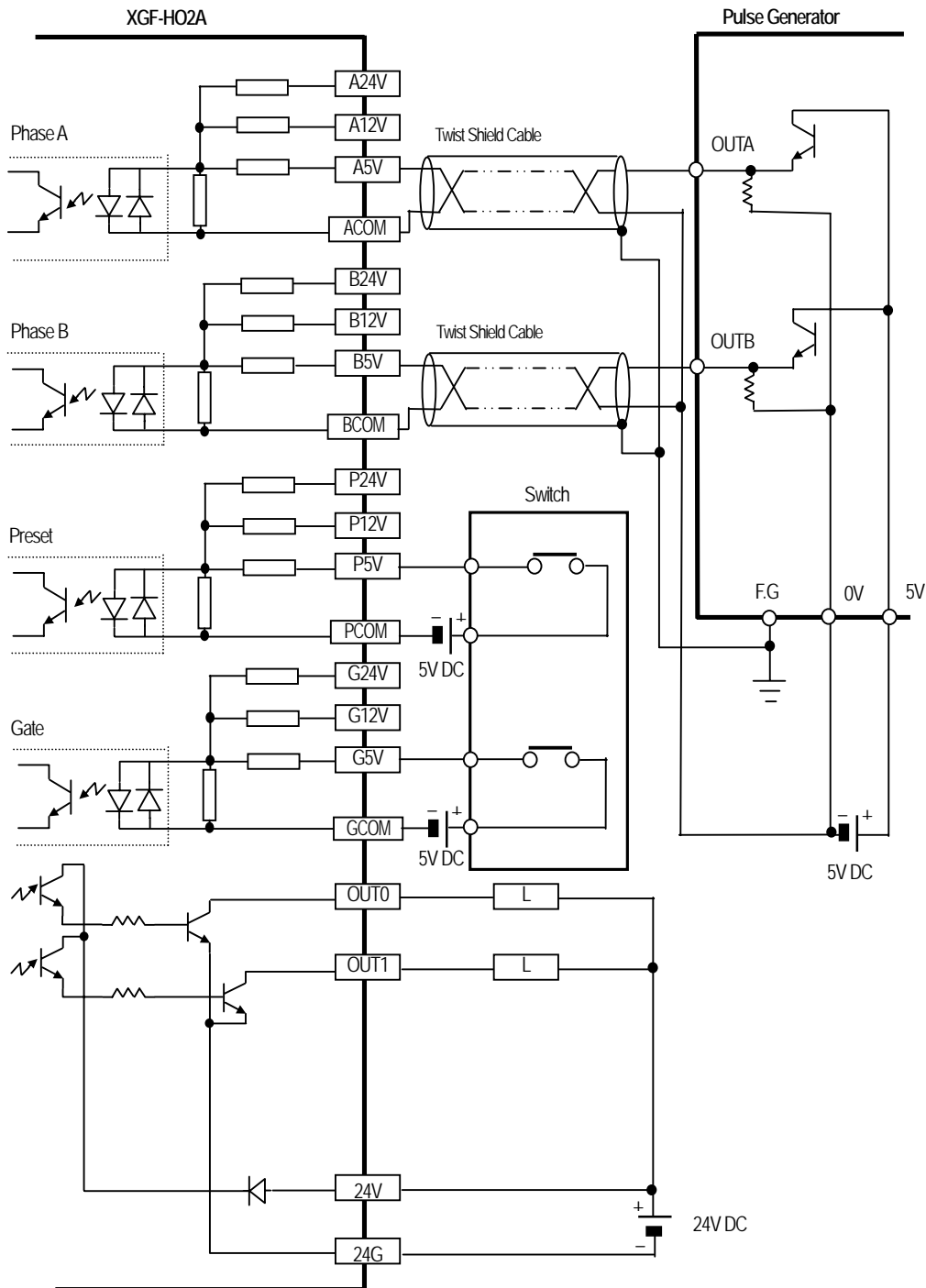

3.2.2 Example of DC12V NPN Open Collector output wiring

This is the wiring example which it used the pulse generator (Encoder or Manual pulse generator) of NPN Open Collector output type.

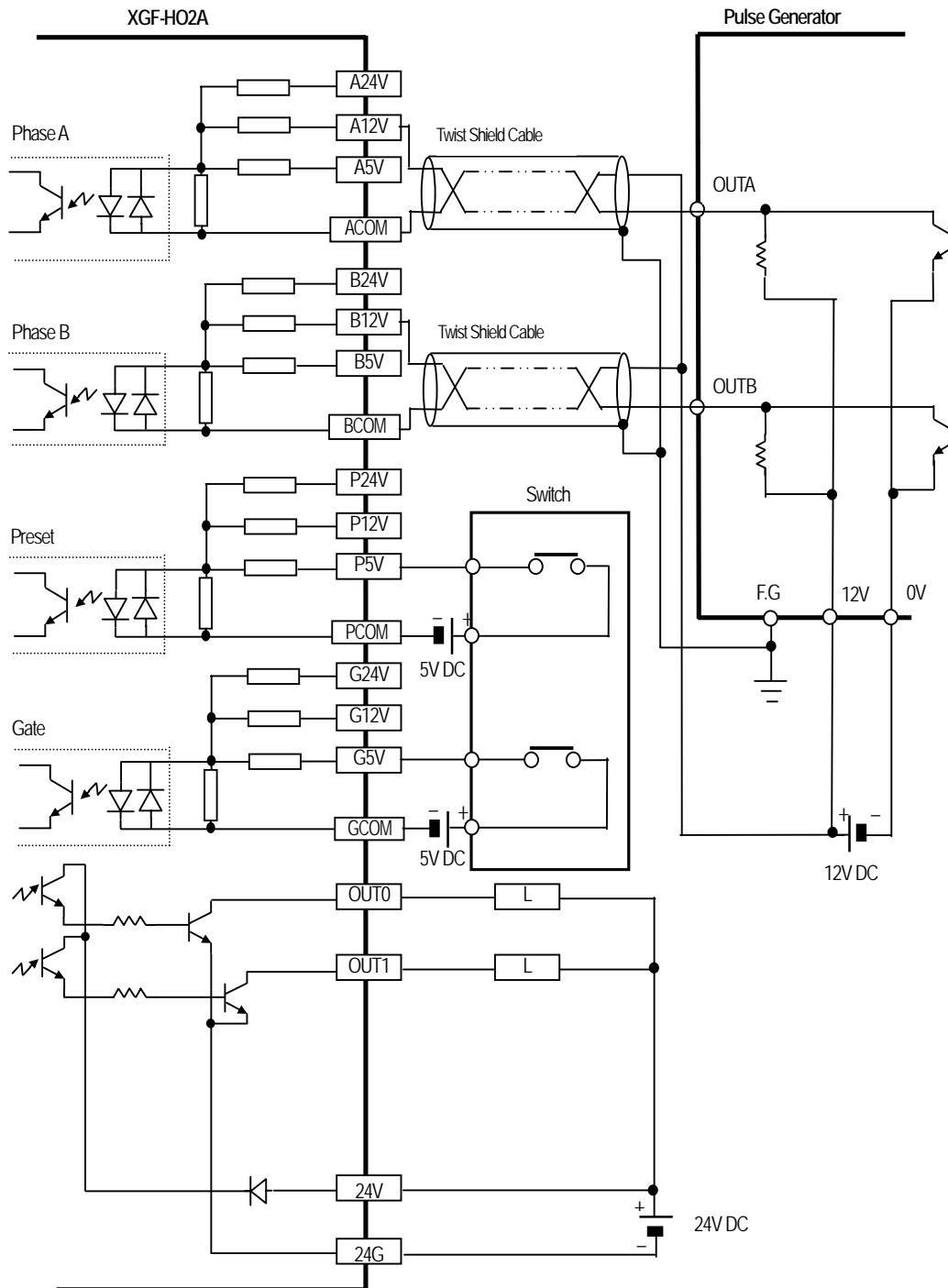

3.2.3 Example of DC24V PNP Open Collector output wiring

This is the wiring example which it used the pulse generator (Encoder or Manual pulse generator) of PNP Open Collector output type.

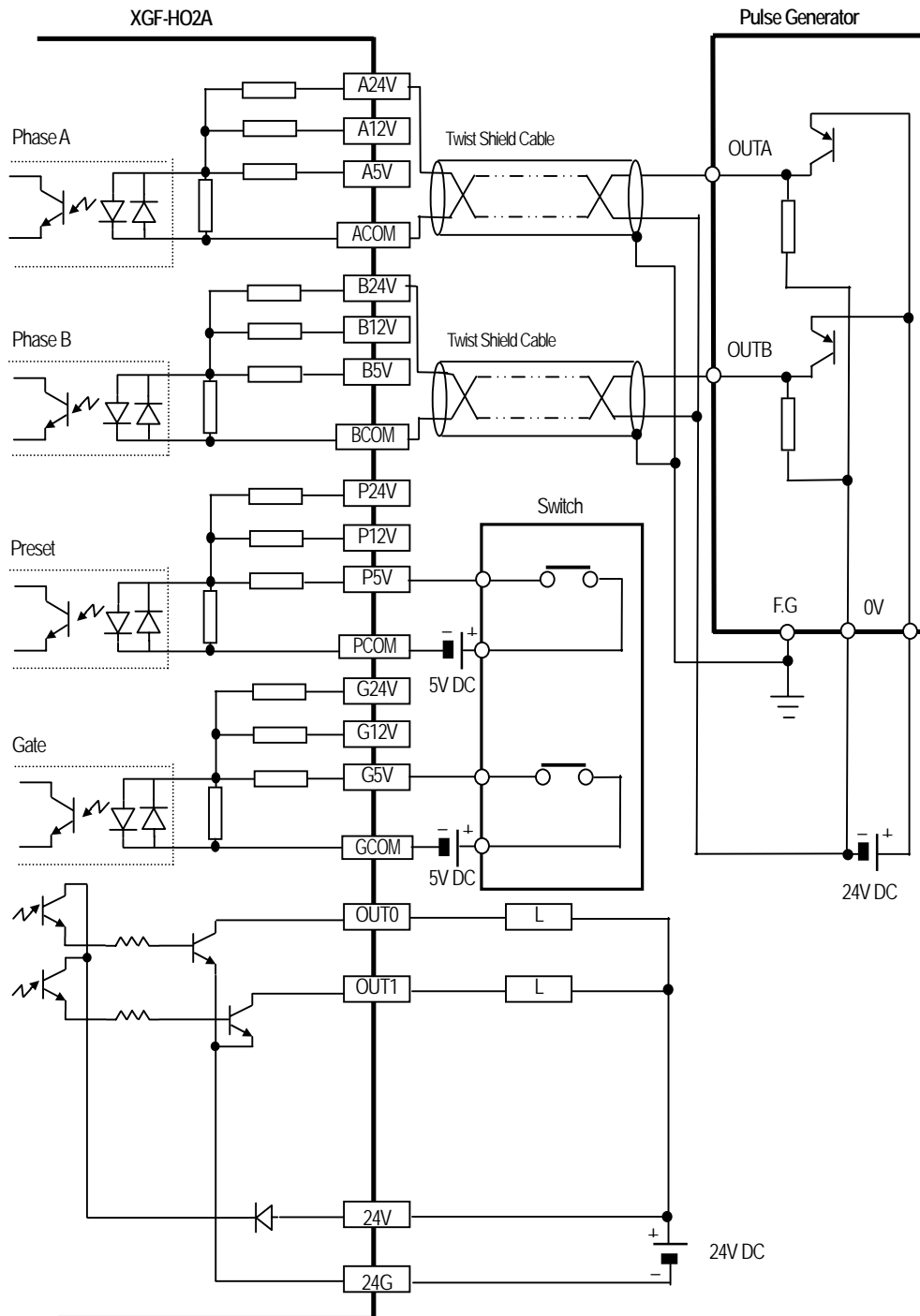

3.2.4 Example of Line Driver output wiring

This is the wiring example which it used the pulse generator (Encoder or Manual pulse generator) of RS-422A Line Driver (5V level) output type.

RS-422A Line Driver (5V Level)

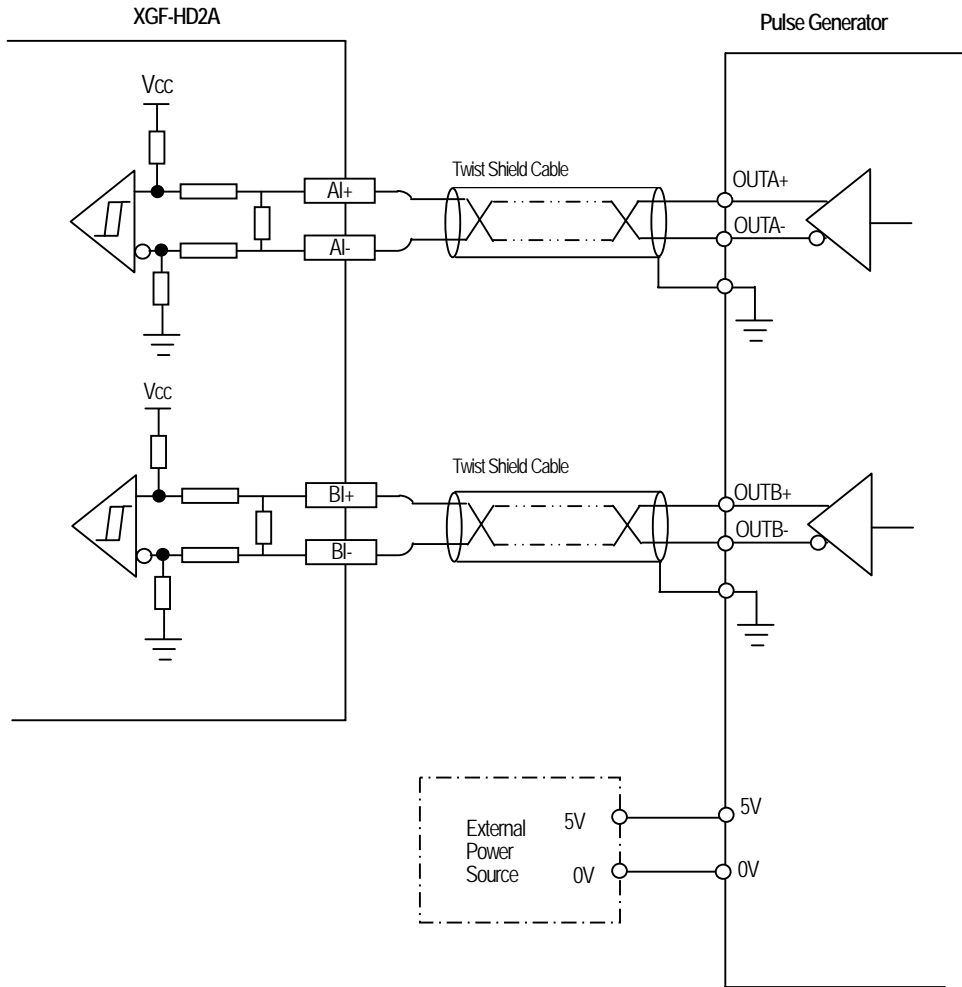

Remark

(1) In case of 24V Level Line Driver, please connect to All+, All-, BII+, BII- terminal.

Chapter 4 Operation Procedures and Monitoring

Operation setting and monitor functions of XG5000 program will be described in this chapter among operation methods of High-speed counter module.

4.1 XG5000 Execution

4.1.1 Execution and Connection of XG5000

- 1) After XG5000 installed, click XG5000 execution icon to display the initial screen of XG5000 program as shown below;

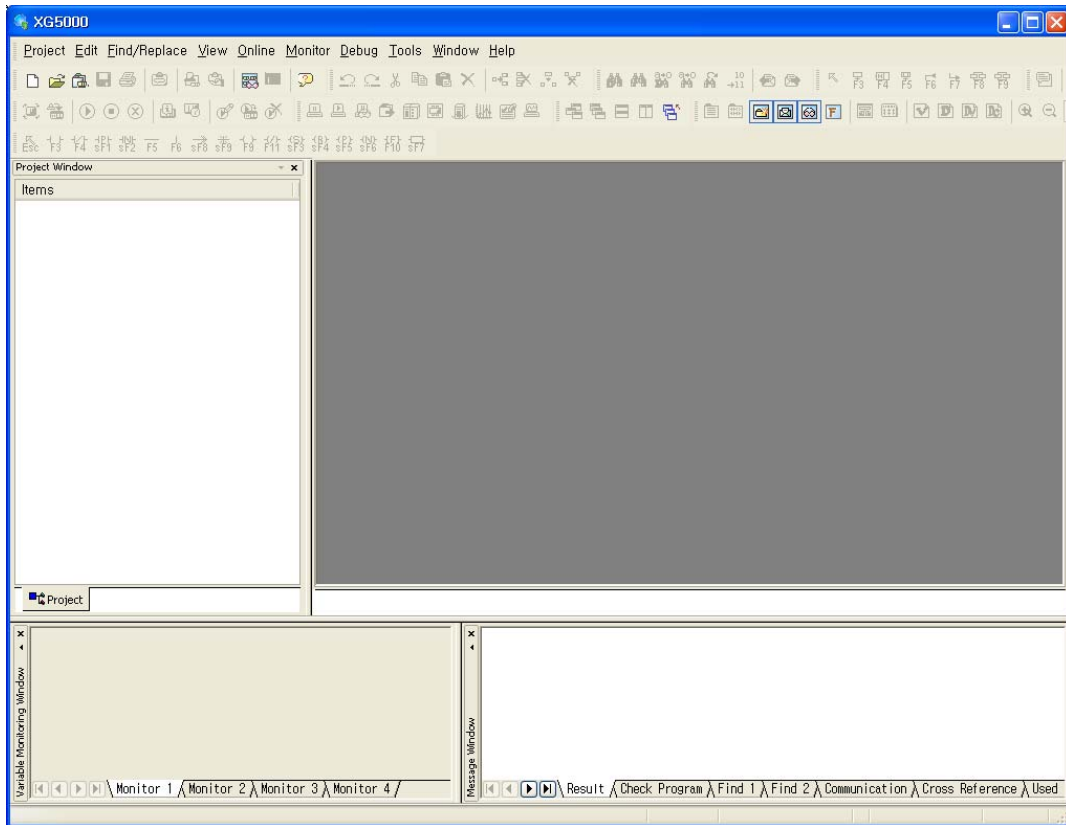

- 2) On the [Project] menu, click [New Project] or  on the icon menu to display the screen as shown below.

XGK-CPUH setting of XGK series

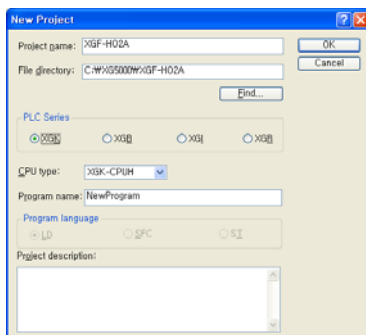

XGI-CPUH setting of XGI series

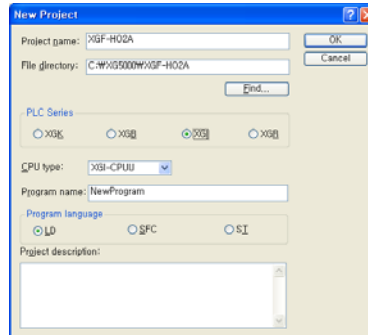

XGR-CPUH setting of XGR series

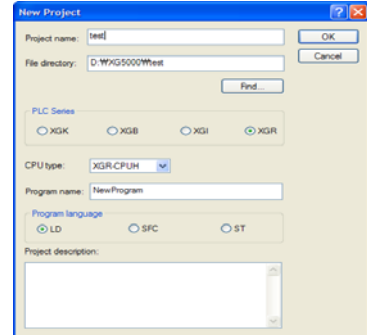

Chapter 4 Operation Procedures and Monitoring

3) Project screen is as below.

Project screen of XGK series

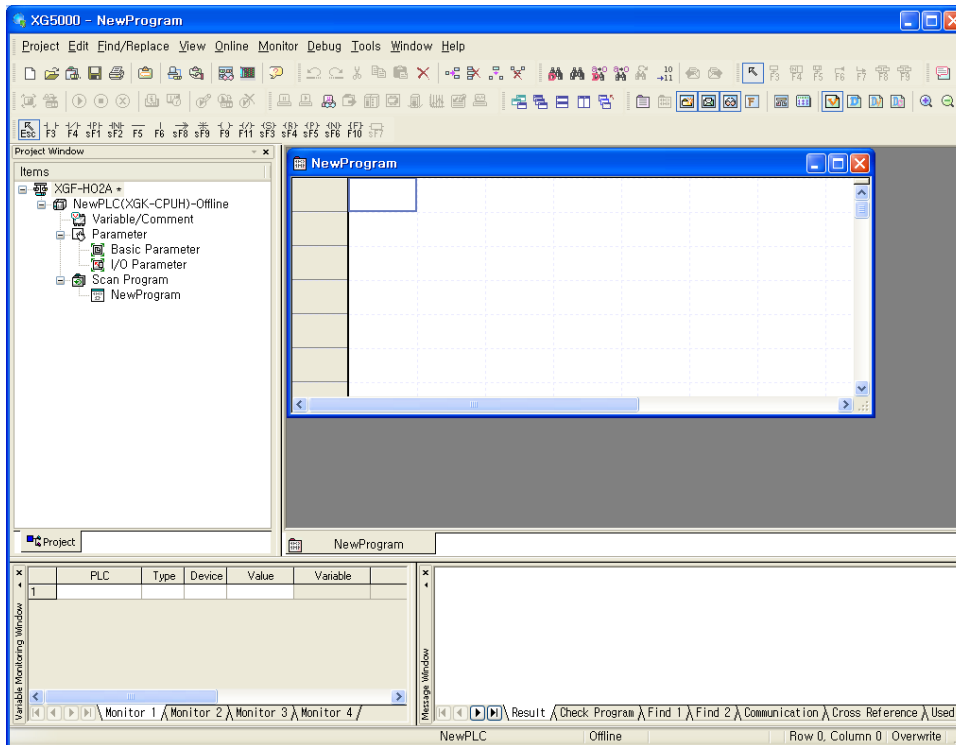

Project screen of XGI series

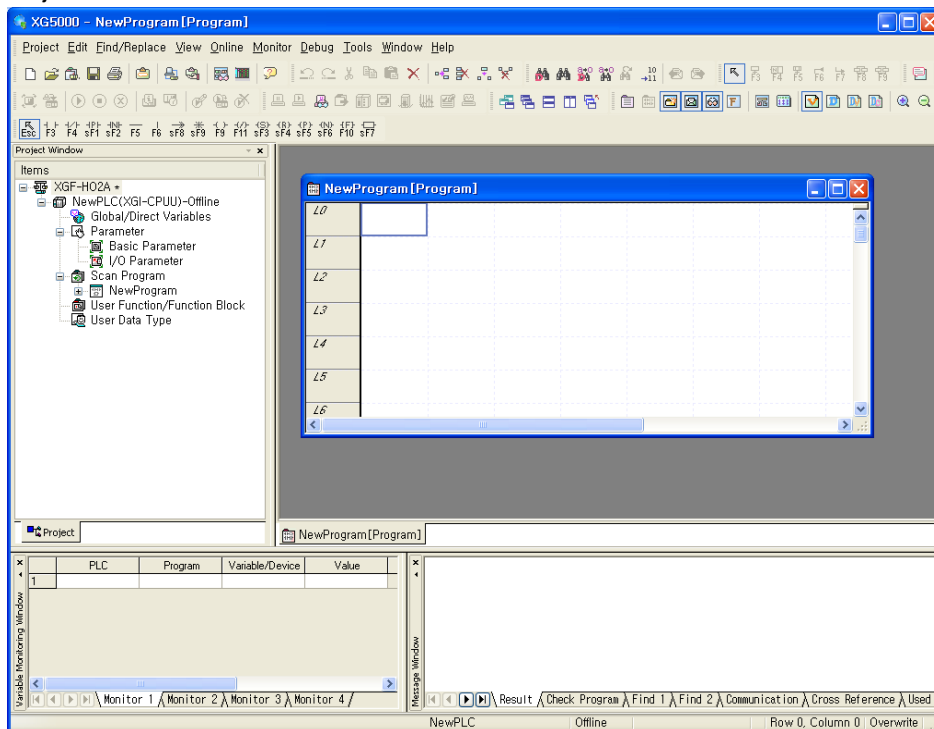

Project screen of XGR series

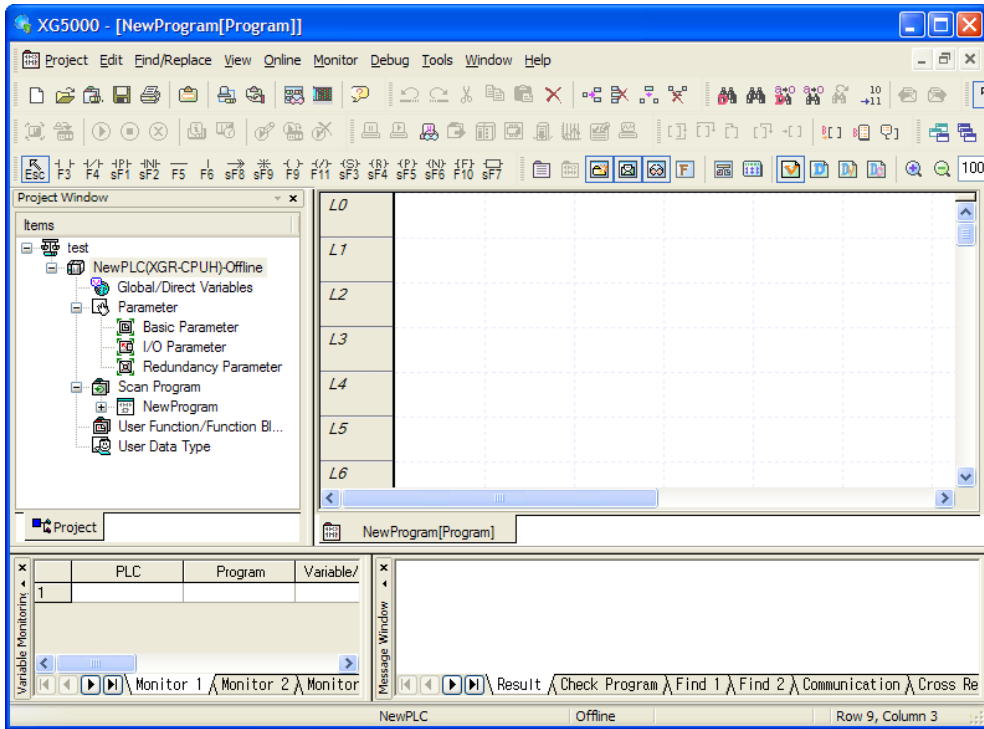

4) If a project is created, click [Online]-[Connection Settings] or  on the icon menu to specify the connection method and connection stage, and then click [Settings] to specify the communication port and the communication speed(115200).

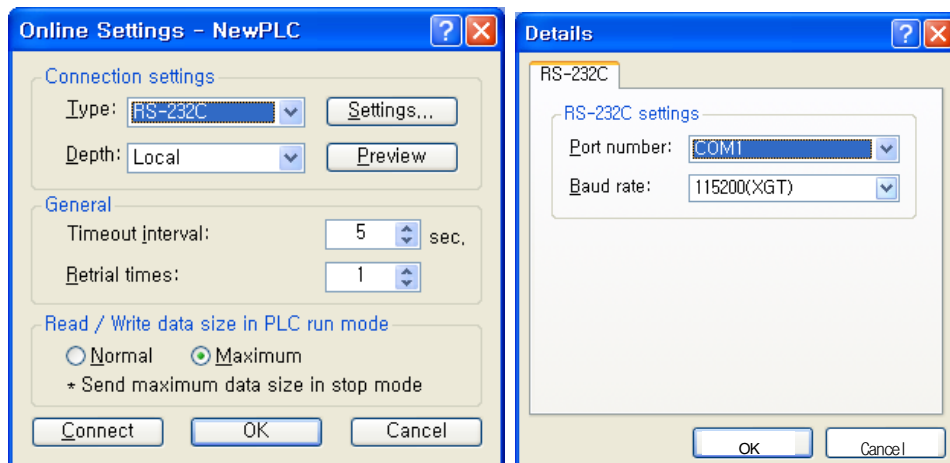

5) After all settings complete, click [Online]-[Connect] or  on the icon menu. Click [Communication] tab on [Message Window] to check the connection.

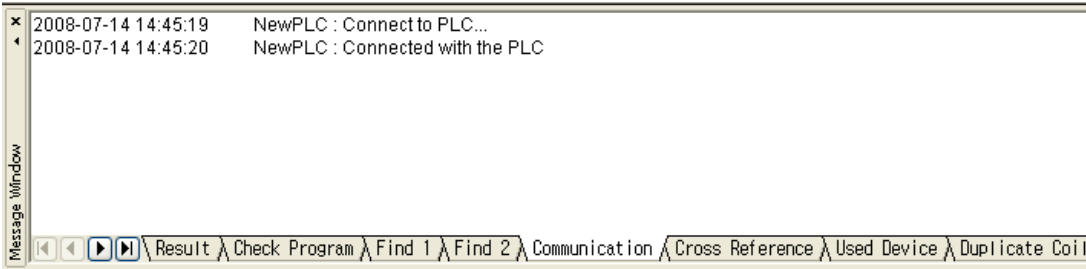

4.2 Parameters Setting

This description is based on XG5000 Project of XGK series, because it is the same to parameter setting method of XGK and XGK series.

4.2.1 Parameters setting

- 1) Double-click [I/O parameters] on the [Project Window] to the left of the project created on XG5000.
- 2) If [I/O parameters setting] window is displayed, click the module area of the applicable slot to select the applicable module

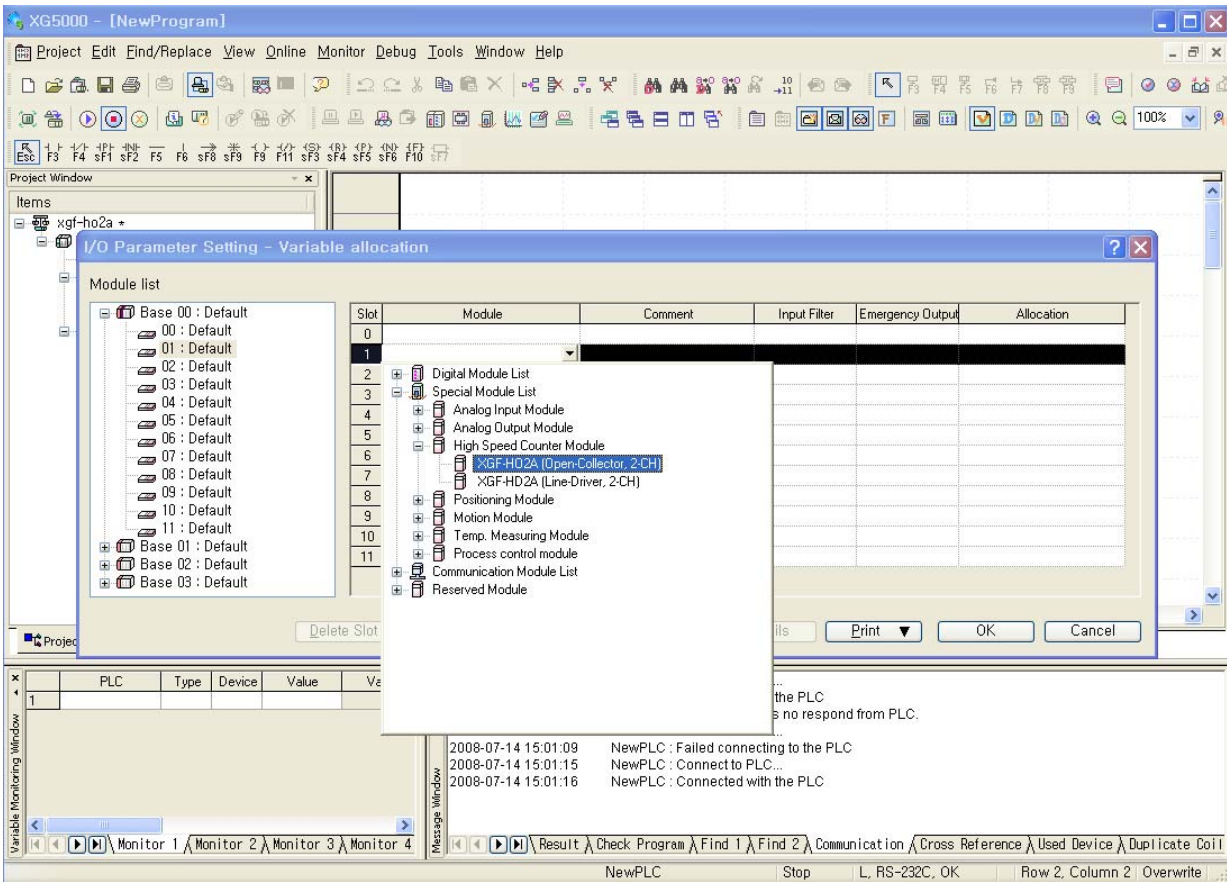

3) Double-click the applicable slot selected to specify the parameters, or click [Details] to display the screen where parameters can be set.

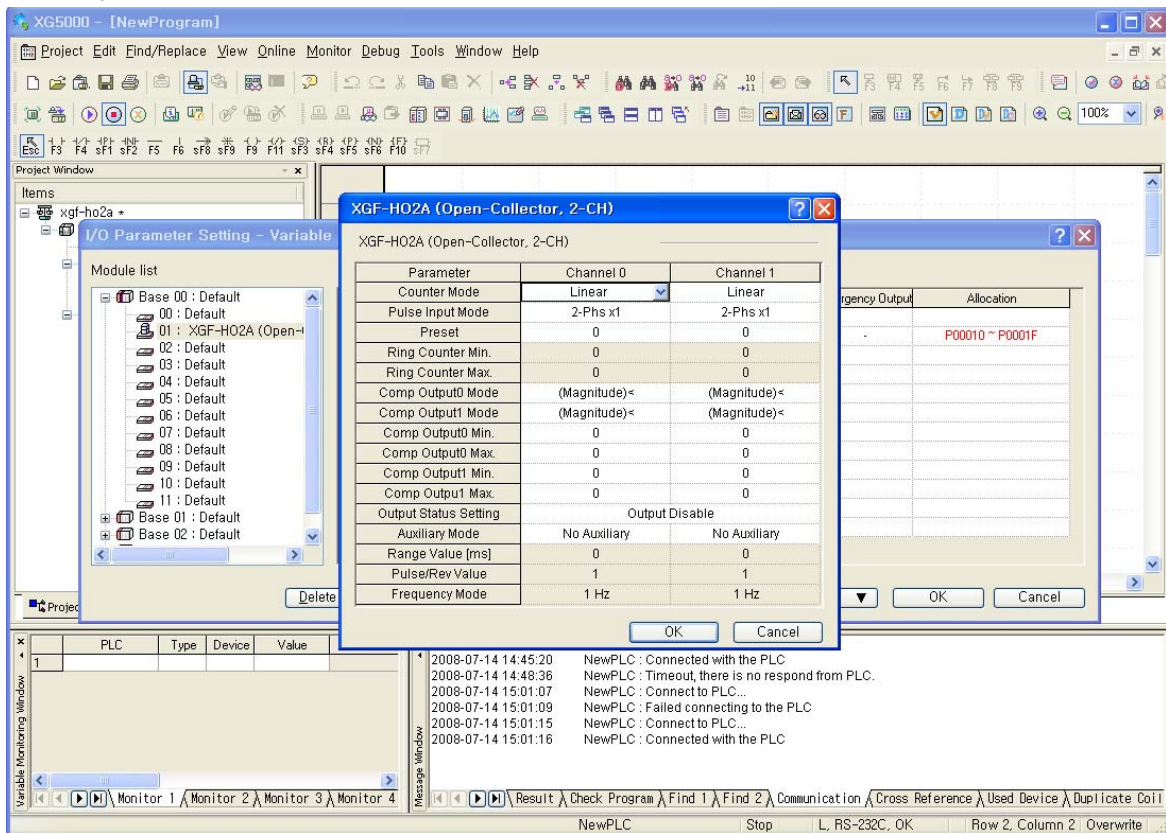

4) Set parameters as necessary for operation on the parameters setting window.

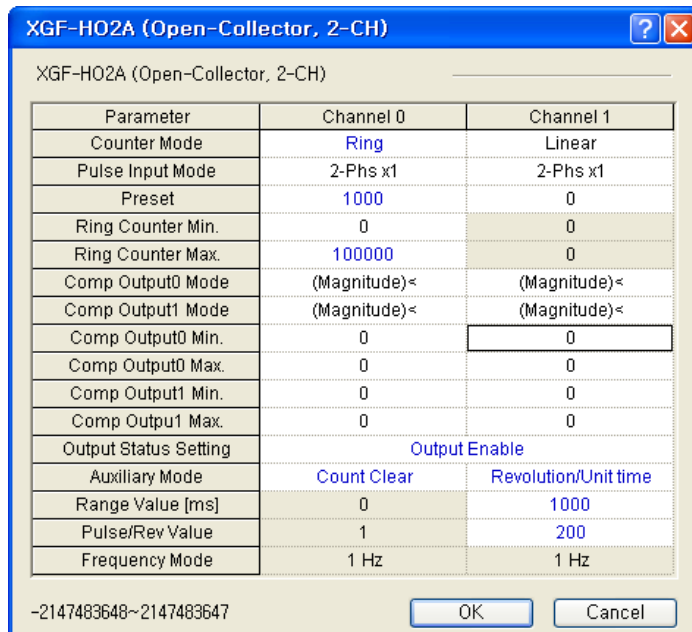

※ You must make the scan program to change parameter of the high speed counter module during CPU RUN mode.

4.3 Monitoring and Test

This description is based on XG5000 Project of XGK series, because it is the same to parameter setting method of XGK and XGK series.

4.3.1 Monitoring and Test

- 1) After connected to PLC CPU through XG5000, click [Online]-[Special Module Monitoring] or  on the icon menu to display the screen as shown below.

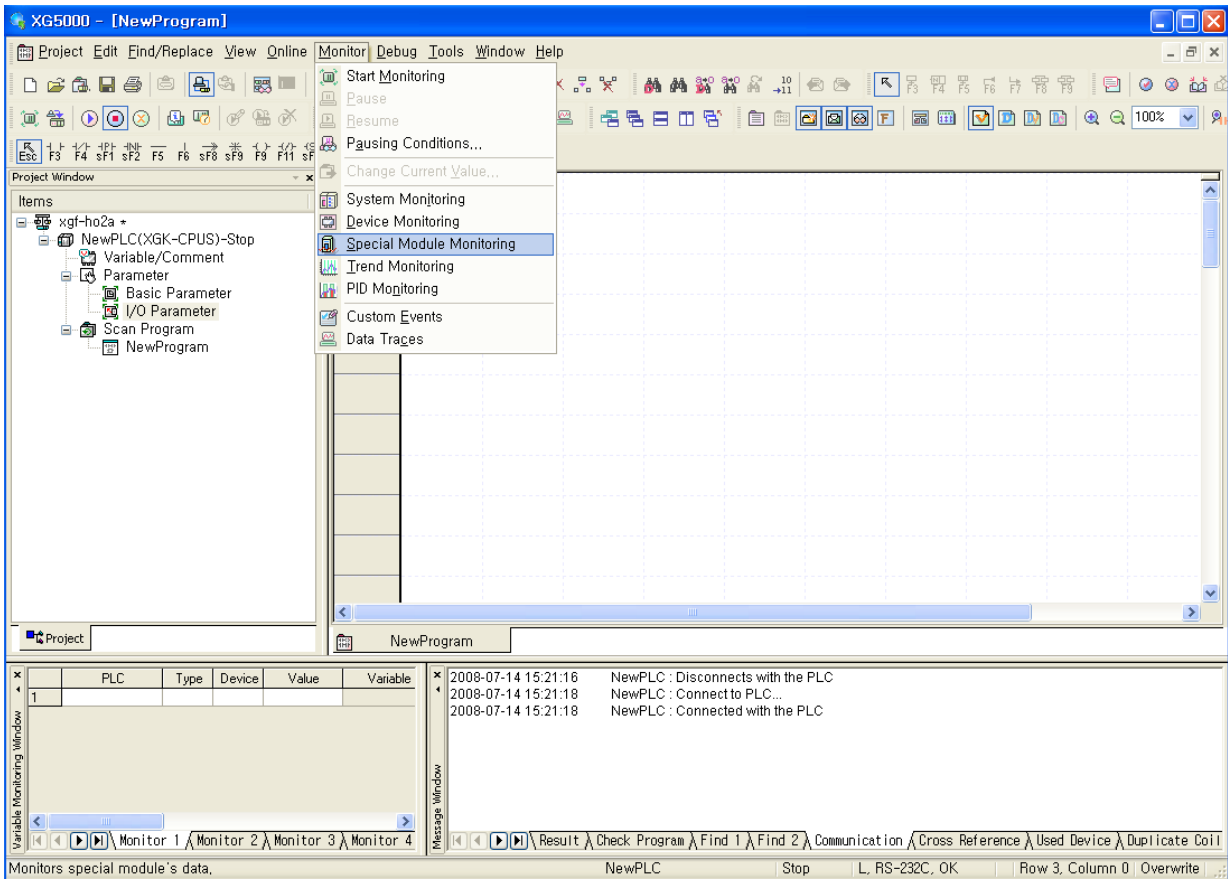

- 2) On the module list dialog box, the special modules presently installed on PLC system will be displayed.

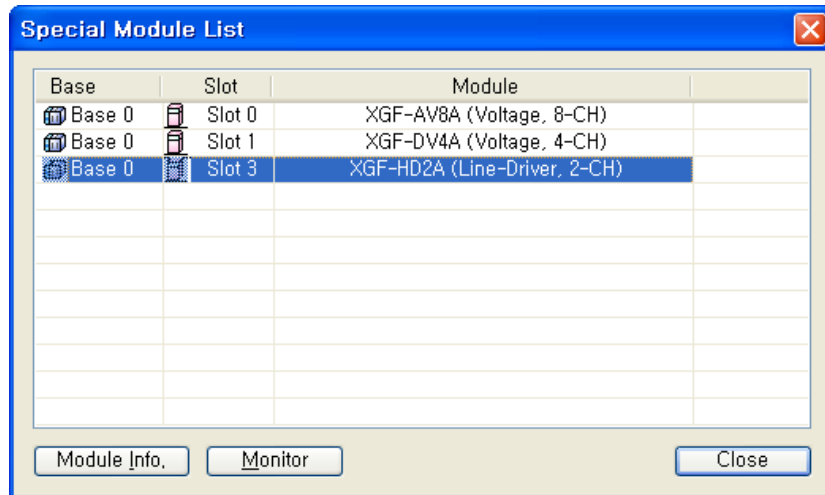

Chapter 4 Operation Procedures and Monitoring

- 3) Select the applicable module and click the monitoring button to display the monitoring/ test screen as shown below, whose functions are as follows;
- On the upper monitoring screen, each special module's monitoring item values are displayed.
 - On the bottom test screen, each module's parameter items can be changed individually.
If you click TEST button, setting values is applied to current value.

Special Module Monitor [?] [X]

XGF-HD2A (Line-Driver, 2-CH)

Item	Channel 0	Channel 1
Current Count Value	0	0
Latch Count Value	0	0
Range Count Value	0	0
Input Frequency	0 (*1)	0 (*1)
Revolution/Unit Time	0	0
FLAG Monitor	<input type="button" value="FLAG Monitor"/>	

Item	Setting Value	Current Value
Channel	Channel 0	
Counter Mode	Linear	Linear
Pulse Input Mode	2-Phs x1	2-Phs x1
Preset	0	0
Ring Counter Min.	0	0
Ring Counter Max.	0	0
Comp Output0 Mode	(Magnitude)<	(Magnitude)<
Comp Output0 Mode	(Magnitude)<	(Magnitude)<
Comp Output0 Min.	0	0
Comp Output0 Max.	0	0
Comp Output1 Min.	0	0
Comp Output1 Max.	0	0
Output Status Setting	Output Enable	Output Enable
Auxiliary Mode	No Auxiliary	No Auxiliary
Range Value [ms]	0	0
Pulse/Rev Value	1	1
Frequency Mode	1 Hz	1 Hz

Remark

- (1) It is applied to only test operation to the parameter which changed by Test button. If test operation is concluded, the high speed counter module is operated by the parameter which was set by I/O parameter or by the scan program.
- (2) If PLC CPU module is STOP mode, it is available to test operation and monitoring function.
But in case of RUN mode, it is available only to monitoring function.

- 4) In order to monitor the I/O contact status, click the applicable channel's flag monitoring button to display the monitoring screen where each I/O contact status can be checked.

HSC Module Command ? X

XGF-HD2A (Line-Driver, 2-CH)

Item	Channel 0	Channel 1
Counter status	Increment	Increment
Ext. preset command flag	OFF	OFF
CARRY flag	OFF	OFF
BORROW flag	OFF	OFF
Auxiliary function flag	OFF	OFF
Comparator Output0 output	OFF	OFF
Comparator Output1 output	OFF	OFF

Command	Channel 0	Channel 1
Counter enable	<input type="button" value="ON"/>	<input type="button" value="ON"/>
Counter preset	<input type="button" value="OFF"/>	<input type="button" value="OFF"/>
Dec. counter	<input type="button" value="OFF"/>	<input type="button" value="OFF"/>
Aux. function	<input type="button" value="OFF"/>	<input type="button" value="OFF"/>
Comp. function	<input type="button" value="ON"/>	<input type="button" value="ON"/>
Comp. Output's ext. output	<input type="button" value="OFF"/>	<input type="button" value="OFF"/>
Comp. Output0 EQUAL reset	<input type="button" value="OFF"/>	<input type="button" value="OFF"/>
Comp. Output1 EQUAL reset	<input type="button" value="OFF"/>	<input type="button" value="OFF"/>
CARRY/BORROW reset	<input type="button" value="OFF"/>	<input type="button" value="OFF"/>
Preset external input	<input type="button" value="OFF"/>	<input type="button" value="OFF"/>
Aux. external input	<input type="button" value="OFF"/>	<input type="button" value="OFF"/>
Ext. preset flag reset	<input type="button" value="OFF"/>	<input type="button" value="OFF"/>

4.4 Registration of U Devices

It is described to the method to register automatically U devices in XG5000 Project of XGK series.

4.4.1 Variable/Comment screen

If you double click [Variables/Comment] of [Project Window], variables and comments which was registered already are displayed.

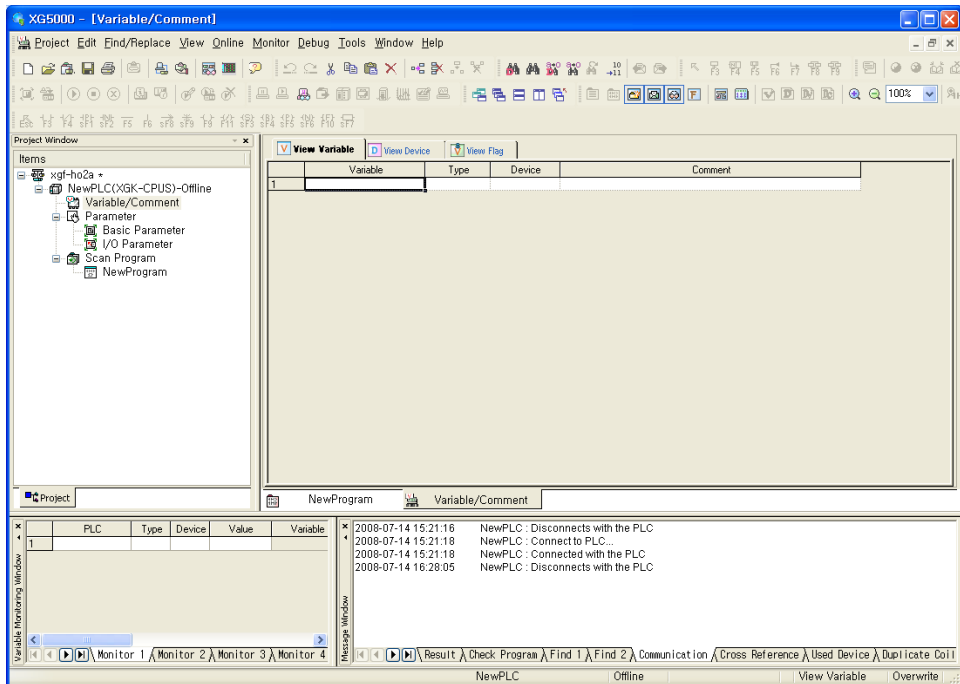

4.4.2 Registration of U Devices

- 1) Select [Edit]→[Register U Device].
(First, [Variable/Comment] window has to be executed.)

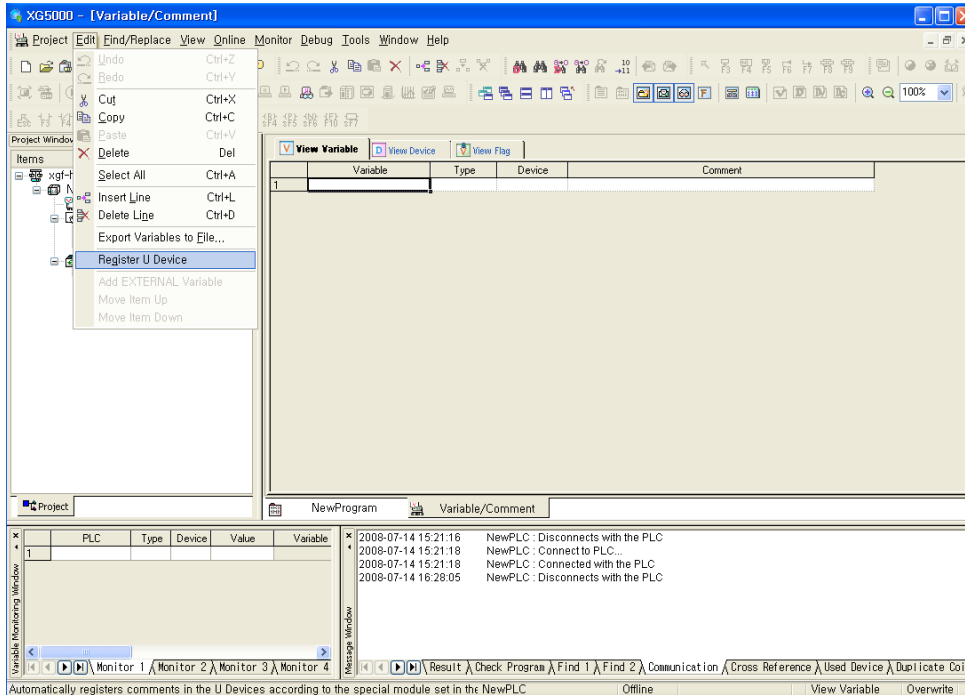

- 2) Click [Yes] to complete the U device registration that is set at [I/O parameter setting]

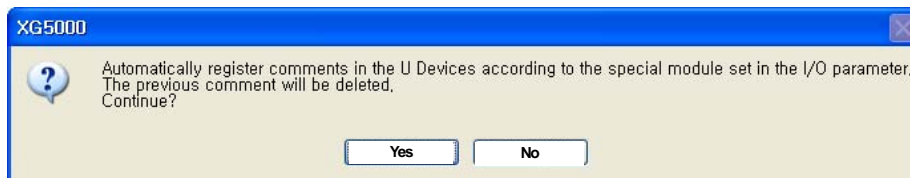

Chapter 4 Operation Procedures and Monitoring

The screenshot displays the XG5000 software interface, specifically the 'Variable/Comment' window. The window title is 'XG5000 - [Variable/Comment]'. The interface includes a menu bar (Project, Edit, Find/Replace, View, Online, Monitor, Debug, Tools, Window, Help), a toolbar, and a Project Window on the left showing a tree view of the project structure.

The main area shows a table with columns: Variable, Type, Device, and Comment. The table lists 24 variables, all of type BIT, with their respective device addresses and comments.

Variable	Type	Device	Comment
_01_CH0_DN	BIT	U01.00.0	HSC Module: CH0 Count Inc/Dec Flag
_01_CH0_EXTPRE	BIT	U01.00.1	HSC Module: CH0 External Preset Command Flag
_01_CH0_CRY	BIT	U01.00.3	HSC Module: CH0 Carry
_01_CH0_BRW	BIT	U01.00.4	HSC Module: CH0 Borrow
_01_CH0_AUXING	BIT	U01.00.5	HSC Module: CH0 Auxiliary Function Flag
_01_CH0_CMPOUT0	BIT	U01.00.6	HSC Module: CH0 Comparator Output0 Output
_01_CH0_CMPOUT1	BIT	U01.00.7	HSC Module: CH0 Comparator Output1 Output
_01_CH0_ERR	BIT	U01.00.E	HSC Module: CH0 Error Flag
_01_RDY	BIT	U01.00.F	HSC Module: Module Ready
_01_CH1_DN	BIT	U01.01.0	HSC Module: CH1 Count Inc/Dec Flag
_01_CH1_EXTPRE	BIT	U01.01.1	HSC Module: CH1 External Preset Command Flag
_01_CH1_CRY	BIT	U01.01.3	HSC Module: CH1 Carry
_01_CH1_BRW	BIT	U01.01.4	HSC Module: CH1 Borrow
_01_CH1_AUXING	BIT	U01.01.5	HSC Module: CH1 Auxiliary Function Flag
_01_CH1_CMPOUT0	BIT	U01.01.6	HSC Module: CH1 Comparator Output0 Output
_01_CH1_CMPOUT1	BIT	U01.01.7	HSC Module: CH1 Comparator Output1 Output
_01_CH1_ERR	BIT	U01.01.E	HSC Module: CH1 Error Flag
_01_CH0_CNTEN	BIT	U01.23.0	HSC Module: CH0 Counter Enable(Level) Command
_01_CH0_PREEN	BIT	U01.23.1	HSC Module: CH0 Preset Enable(Edge) Command
_01_CH0_DWNCNT	BIT	U01.23.2	HSC Module: CH0 Inc/Dec Count Setting(Level) Command
_01_CH0_AUXEN	BIT	U01.23.3	HSC Module: CH0 Auxiliary Function Enable(Edge,Level) Command
_01_CH0_CMPEN	BIT	U01.23.4	HSC Module: CH0 Count Comparison Function Enable(Level) Command
_01_CH0_OUTEN	BIT	U01.23.5	HSC Module: CH0 Comparator Output Enable(Level) Command
_01_CH0_ERR	BIT	U01.23.C	HSC Module: CH0 Error Enable(Level) Command

At the bottom of the window, there is a 'Variable Monitoring Window' with a table for monitoring variables and a 'Message Window' showing system messages. The status bar at the very bottom indicates 'NewPLC', 'Offline', and 'View Variable'.

4.5 Registration of Special module variable

It is described to the method to register automatically variables[Global variables/Constants] of high speed counter module in XG5000 Project of XGI series.

4.5.1 Global/Direct Variables screen

If you double click [Global/direct Variables] of [Project Window], variables and comments which was registered already are displayed.

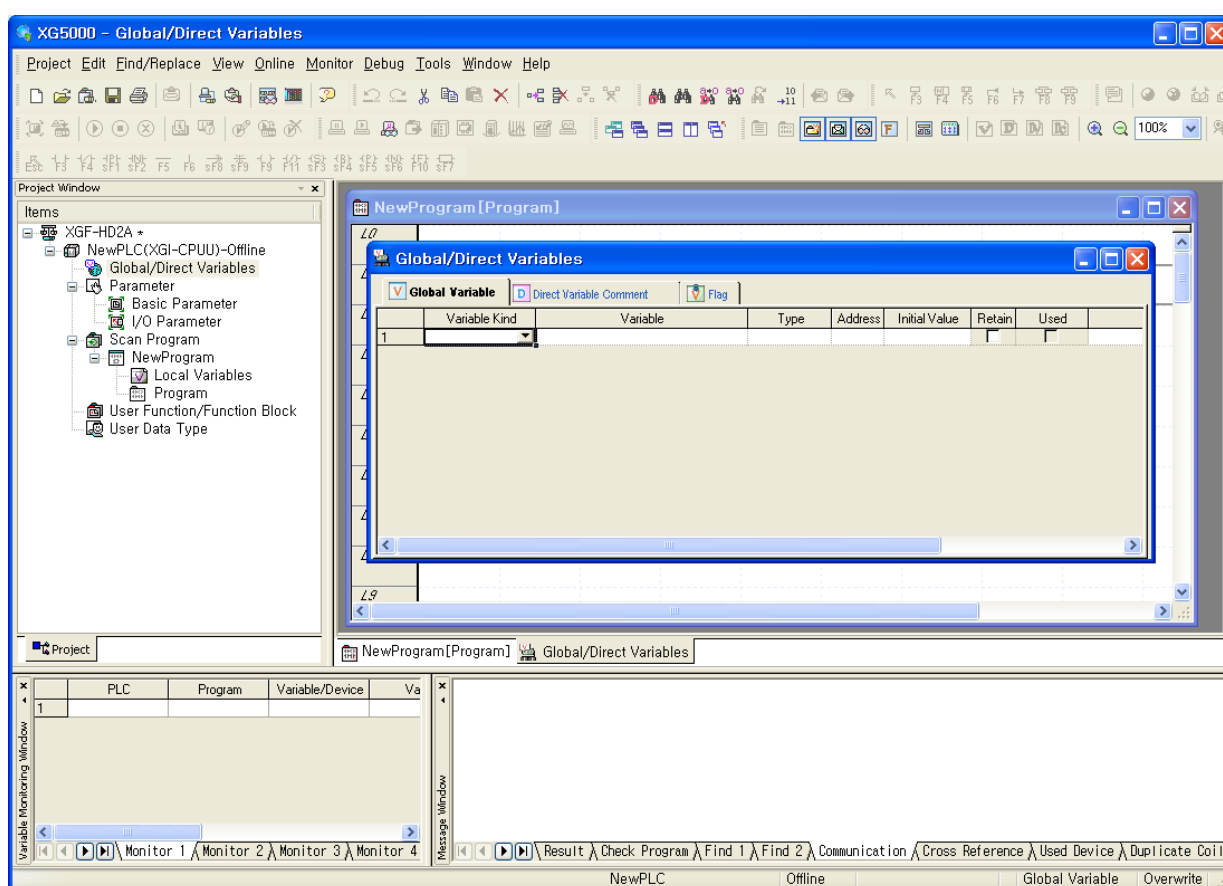

4.5.2 Registration of the special module variables

- 1) Select [Edit]→ [Register Special Module variables].
(First, [Global/Direct Variables] window has to be executed.)

Chapter 4 Operation Procedures and Monitoring

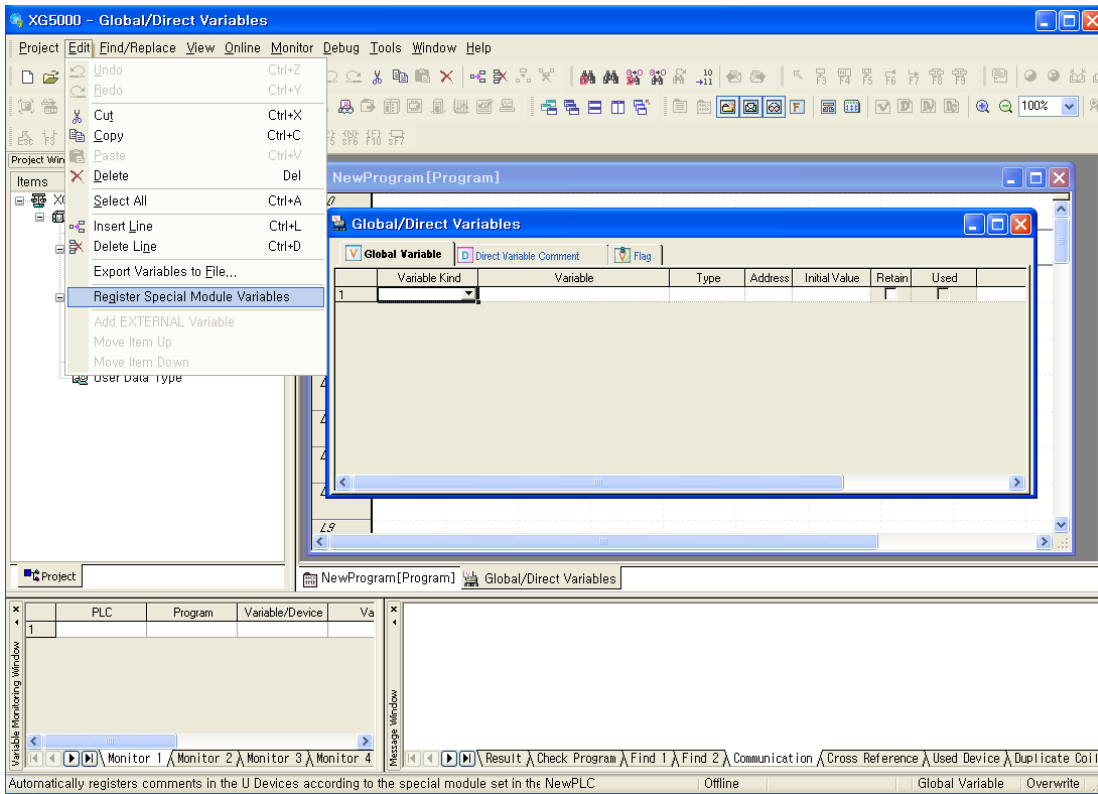

- 2) Click [Yes] to complete the special module variables registration that is set at [I/O parameter setting]

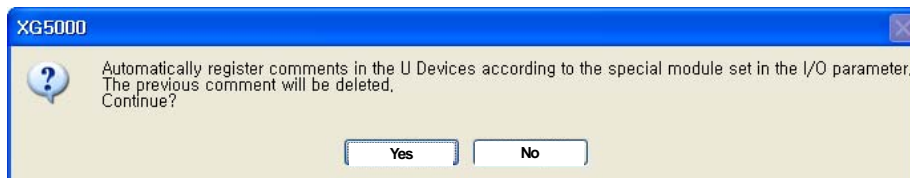

Chapter 4 Operation Procedures and Monitoring

The screenshot shows the 'Global/Direct Variables' window in the XG5000 software. The window title is 'XG5000 - [Global/Direct Variables]'. The main area contains a table of variables:

Variable Kind	Variable	Type	Address	Initial Value	Retain	Used	Comment
VAR_GLOBAL	_0001_CH0_ALXEN	BOOL					HSC Module: CH0 Auxiliary Function Ena
VAR_GLOBAL	_0001_CH0_ALXING	BOOL					HSC Module: CH0 Auxiliary Function Flag
VAR_GLOBAL	_0001_CH0_BRW	BOOL					HSC Module: CH0 Borrow
VAR_GLOBAL	_0001_CH0_CMPEN	BOOL					HSC Module: CH0 Count Comparison Fun
VAR_GLOBAL	_0001_CH0_CMPOUT0	BOOL					HSC Module: CH0 Comparator Output0 0
VAR_GLOBAL	_0001_CH0_CMPOUT1	BOOL					HSC Module: CH0 Comparator Output1 0
VAR_GLOBAL	_0001_CH0_CNT	DINT					HSC Module: CH0 Current Count
VAR_GLOBAL	_0001_CH0_CNTEN	BOOL					HSC Module: CH0 Counter Enable(Level)
VAR_GLOBAL	_0001_CH0_CRY	BOOL					HSC Module: CH0 Carry
VAR_GLOBAL	_0001_CH0_CRYBRW_RST	BOOL					HSC Module: CH0 Carry/Borrow Reset(E
VAR_GLOBAL	_0001_CH0_DN	BOOL					HSC Module: CH0 Count Inc/Dec Flag
VAR_GLOBAL	_0001_CH0_DWNCNT	BOOL					HSC Module: CH0 Inc/Dec Count Setting
VAR_GLOBAL	_0001_CH0_EQORST	BOOL					HSC Module: CH0 Comp-Output 0 EQUA
VAR_GLOBAL	_0001_CH0_EQ1RST	BOOL					HSC Module: CH0 Comp-Output 1 EQUA
VAR_GLOBAL	_0001_CH0_ERR	BOOL					HSC Module: CH0 Error Flag
VAR_GLOBAL	_0001_CH0_EXTALK_EN	BOOL					HSC Module: CH0 Aux-Func Ext. Input S
VAR_GLOBAL	_0001_CH0_EXTPRE	BOOL					HSC Module: CH0 External Preset Comm
VAR_GLOBAL	_0001_CH0_EXTPST_EN	BOOL					HSC Module: CH0 External Preset Input
VAR_GLOBAL	_0001_CH0_EXTPST_RST	BOOL					HSC Module: CH0 Ext. Preset Detect Fla
VAR_GLOBAL	_0001_CH0_FRQ	UDINT					HSC Module: CH0 Input Frequency
VAR_GLOBAL	_0001_CH0_LTH	DINT					HSC Module: CH0 Latch Count
VAR_GLOBAL	_0001_CH0_OUTEN	BOOL					HSC Module: CH0 Comparator Output En
VAR_GLOBAL	_0001_CH0_PREEN	BOOL					HSC Module: CH0 Preset Enable(Edge) C
VAR_GLOBAL	_0001_CH0_PRES	DINT					HSC Module: CH0 Preset Value

Below the table is a 'Variable Monitoring Window' with a table for monitoring variables:

PLC	Program	Variable/Device	Value
1			

The bottom status bar shows 'NewPLC', 'Offline', 'Global Variable', and 'Overwrite'.

Chapter 5 Internal Memory & I/O Signals

5.1 Internal Memory

- High Speed Counter has the internal memory used for data "Write/Read" to/from PLC CPU. The commands used for "Write" from PLC CPU to High Speed Counter's internal memory are PUT and PUTP, and the commands used for "Read" are GET and GETP. Configuration of the internal memory and the data is as described below.

5.1.1 Configuration of the internal memory

1) Input setting area

Internal memory address		Details	Data setting range
Channel 0	Channel 1		
0	25	Select counter mode	0 or 1
1	26	Select pulse input mode	0 ~ 7
2	27	Set preset value	-2147483648~ 2147483648
3	28		
4	29	Minimum value of Ring count	-2147483648~ 2147483648
5	30		
6	31	Maximum value of Ring count	-2147483648~ 2147483648
7	32		
8	33	Select OUT 0 type	0 ~ 6
9	34	Select OUT 1 type	0 ~ 6
10	35	OUT0 compared based value (single-compared)/ minimum setting value (section compared)	-2147483648~ 2147483648
11	36		
12	37	OUT0 compared based value maximum setting value (section- compared)	-2147483648~ 2147483648
13	38		
14	39	OUT1 compared based value (single-compared)/ minimum setting value (section-compared)	-2147483648~ 2147483648
15	40		
16	41	OUT1 compared based value maximum setting value (section-compared)	-2147483648~ 2147483648
17	42		
18	43	Select auxiliary mode	0 ~ 6
19	44	Sampling count time setting or Revolution/Unit time setting	0 ~ 60000
20	45	Revolutions per hour function, pulses per revolution input	0 ~ 60000
21	46	Select frequency display mode	0 ~ 3

2) Setting area of comparison output status

Internal memory address		Details	Data setting range
Channel 0	Channel 1		
50		Define output status when PLC CPU stops (CH0, CH1 common)	0 or 1

3) Output area of error code

Internal memory address		Details	Command
Channel 0	Channel 1		
51		Error code (channel 0, channel 1 common)	GET

5.1.2 Details & Data Configuration

1) Count mode setting (CH0: 0 address, CH1: 25 address)

Setting value(Dec)	Details
0	Linear count
1	Ring count

2) Pulse input mode setting (CH0: 1 address, CH1: 26 address)

Setting value(Dec)	Details
0	2-phase 1-multiplication
1	2-phase 2-multiplication
2	2-phase 4-multiplication
3	CW / CCW
4	1-phase, 1-input, 1-multiplication
5	1-phase, 1-input, 2-multiplication
6	1-phase, 2-input, 1-multiplication
7	1-phase, 2-input, 2-multiplication

3) Comparison output types (CH0: 8, 9 address, CH1: 33, 34 address)

Setting value	Details
0	If present value < compared reference value, OUT□ is On
1	If present value =< compared reference value, OUT□ is On
2	If present value = compared reference value, OUT□ is On
3	If present value >= compared reference value, OUT□ is On
4	If present value > compared reference value, OUT□ is On
5	If compared minimum value =< present value =< compared maximum value, OUT□ is On
6	If compared minimum value >= present value, present value >= compared maximum value, OUT□ is On

※ Here, □ means 0 or 1.

4) Auxiliary mode setting (CH0: 18 address, CH1: 43 address)

Setting value(Dec)	Details
0	Auxiliary mode is not used
1	Count Clear
2	Count Latch
3	Sampling Count
4	Input Frequency Measure
5	Revolution/Unit time
6	Count Disable

5) Frequency mode setting (CH0: 21 address, CH1: 46 address)

Setting value(Dec)	Details
0	1 Hz unit displayed
1	10 Hz unit displayed
2	100 Hz unit displayed
3	1000 Hz unit displayed (= 1kHz)

6) Output status setting at PLC stop (CH0, CH1 common: 50 address)

Setting value(Dec)	Details
0	Output disable
1	Output kept as it is

5.2 I/O Signals

1) Output setting area

Channel 0	Channel 1	Details
Uxy.02 ~ Uxy.03	Uxy.12 ~ Uxy.13	Present count value
Uxy.04 ~ Uxy.05	Uxy.14 ~ Uxy.15	Latch count value
Uxy.06 ~ Uxy.07	Uxy.16 ~ Uxy.17	Sampling count value
Uxy.08 ~ Uxy.09	Uxy.18 ~ Uxy.19	Input frequency value
Uxy.10 ~ Uxy.11	Uxy.20 ~ Uxy.21	Revolutions per hour value

※ Here, 'xy' stands for the position High Speed Counter module is installed on. (xy => x:base no., y:slot no.)

2) Operation status display and Operation command area

CH	PLC <- High Speed Counter		PLC -> High Speed Counter	
	Signal	Details	Signal	Details
0	Uxy.00.0	Increasing/decreasing count signal (ON: decreasing/OFF: increasing)	Uxy.23.0	Count operation enable signal (Level)
	Uxy.00.1	External input preset flag	Uxy.23.1	Preset enable signal (edge)
	Uxy.00.2	-	Uxy.23.2	Increasing/decreasing count setting signal (Level)
	Uxy.00.3	Carry signal	Uxy.23.3	Auxiliary mode use command(edge, level)
	Uxy.00.4	Borrow signal	Uxy.23.4	Compared function use command(Level)
	Uxy.00.5	Flag during auxiliary mode	Uxy.23.5	Compared output external terminal enabled signal(Level)
	Uxy.00.6	OUT0 output signal	Uxy.23.6	OUT0 coincidence output reset signal (Edge)
	Uxy.00.7	OUT1 output signal	Uxy.23.7	OUT1 coincidence output reset signal (Edge)
	Uxy.00.8	-	Uxy.23.8	-
	Uxy.00.9	-	Uxy.23.9	-
	Uxy.00.A	-	Uxy.23.A	Carry/Borrow reset signal (Edge)
	Uxy.00.B	-	Uxy.23.B	Preset external input setting signal
	Uxy.00.C	-	Uxy.23.C	Command of auxiliary mode use (external input setting signal(gate signal))
	Uxy.00.D	-	Uxy.23.D	External input preset flag reset signal
	Uxy.00.E	CH0 error flag	Uxy.23.E	-
Uxy.00.F	Module Ready	Uxy.23.F	-	
1	Uxy.01.0	Increasing/decreasing count signal (ON: decreasing/OFF: increasing)	Uxy.24.0	Count operation enable signal (Level)
	Uxy.01.1	External input preset flag	Uxy.24.1	Preset enable signal (edge)
	Uxy.01.2	-	Uxy.24.2	Increasing/decreasing count setting signal (Level)
	Uxy.01.3	Carry signal	Uxy.24.3	Additional function use command (edge, level)
	Uxy.01.4	Borrow signal	Uxy.24.4	Compared function use command (Level)
	Uxy.01.5	Flag during auxiliary mode	Uxy.24.5	Compared output external terminal enabled signal (Level)
	Uxy.01.6	OUT0 output signal	Uxy.24.6	OUT0 coincidence output reset signal (Edge)
	Uxy.01.7	OUT1 output signal	Uxy.24.7	OUT1 coincidence output reset signal (Edge)
	Uxy.01.8	-	Uxy.24.8	-
	Uxy.01.9	-	Uxy.24.9	-
	Uxy.01.A	-	Uxy.24.A	Carry/Borrow reset signal (Edge)
	Uxy.01.B	-	Uxy.24.B	Preset external input setting signal
	Uxy.01.C	-	Uxy.24.C	Command of auxiliary mode use (external input setting signal(gate signal))
	Uxy.01.D	-	Uxy.24.D	External input preset flag reset signal
	Uxy.01.E	CH1 error flag	Uxy.24.E	-
Uxy.01.F	-	Uxy.24.F	-	

※ Here, the size of Uxy.ab is 1 word and the size of Uxy.ab.i is 1 bit.

Chapter 6 Global Constant and Global Variable

It is described to global constant and global variable for XGI/XGR series.

Remark

It is terminology for XGI/XGR series to Global constant(VAL_GLOBAL_CONST) and Global variable(VAL_GLOBAL).
In XGK series, global constant is equivalent to the internal memory, global variable is to input/output signal(U device).

6.1 Global Constant

CPU module of XGI/XGR series are sharing the global constant area for the data transmission and receiving. It is PUT_#### for the function block to transmit the data form XGI/XGR CPU module to the global constant area of the high speed counter module, the receiving function block is GET_####. About PUT_####, GET_#### function block, please refer to the 'chapter 7 Programming'.

6.1.1 The configuration of Global Constant

1. Input data

Channel 0 Channel 1	Constant Value	Contents	Data setting range
Fxy_CH0_CNT_MODE Fxy_CH1_CNT_MODE	00 25	Count types	0 or 1
Fxy_CH0_PLS_MODE Fxy_CH1_PLS_MODE	01 26	Pulse input types	0 ~ 7
Fxy_CH0_PRESET Fxy_CH1_PRESET	02 27	Preset value	-2147483648 ~ 2147483647
Fxy_CH0_RING_MIN Fxy_CH1_RING_MIN	04 29	Ring count minimum value	-2147483648 ~ 2147483647
Fxy_CH0_RING_MAX Fxy_CH1_RING_MAX	06 31	Ring count maximum value	-2147483648 ~ 2147483647
Fxy_CH0_CP0_MODE Fxy_CH1_CP0_MODE	08 33	Type of comparison output 0	0 ~ 6
Fxy_CH0_CP1_MODE Fxy_CH1_CP1_MODE	09 34	Type of comparison output 1	0 ~ 6
Fxy_CH0_CP0_MIN Fxy_CH1_CP0_MIN	10 35	Comparison reference value of comparison output 0(single comparison)/minimum value(section comparison)	-2147483648 ~ 2147483647
Fxy_CH0_CP0_MAX Fxy_CH1_CP0_MAX	12 37	Maximum value of comparison output 0 (section comparison)	-2147483648 ~ 2147483647
Fxy_CH0_CP1_MIN Fxy_CH1_CP1_MIN	14 39	Comparison reference value of comparison output 1(single comparison)/minimum value(section comparison)	-2147483648 ~ 2147483647
Fxy_CH0_CP1_MAX Fxy_CH1_CP1_MAX	16 41	Maximum value of comparison output 1 (section comparison)	-2147483648 ~ 2147483647
Fxy_CH0_AUX_MODE Fxy_CH1_AUX_MODE	18 43	Type of additional function	0 ~ 6
Fxy_CH0_PERIOD Fxy_CH1_PERIOD	19 44	Setting time of sampling count or of setting time "revolution per unit time"	0 ~ 60000
Fxy_CH0_REV_UNIT Fxy_CH1_REV_UNIT	20 45	Pulse per 1 rotation of "revolution per unit time"	0 ~ 60000
Fxy_CH0_FREQ_MODE Fxy_CH1_FREQ_MODE	21 46	Frequency display unit of "input frequency measure"	0 ~ 3

Remark

- (1) 'Fxy' : 'x' means the base number of the high speed counter module, 'y' means the slot number of it.
- (2) Constant value can not be modified, because it is the address of input data area.
- (3) Constant value is the same as the internal memory address of XGK series.

Chapter 6 Global Constant and Global Variable

2. Setting area of comparison output status

Channel 0 Channel 1	Constant value	Contents	Data setting range
_Fxy_PLCSTOP_OUT_EN	50	When XGI CPU module is STOP mode, comparison output status (channel 0, channel 1 common)	0 or 1

3. Output area of the error code

Channel 0 Channel 1	Constant value	Contents	Data setting range
_Fxy_ERR_CODE	51	Error code (channel 0, channel 1 common)	GET_###

6.1.2 The Configuration and Contents of Data

1. Count types (channel 0: _Fxy_CH0_CNT_MODE, channel 1: _Fxy_CH1_CNT_MODE)

Setting value	Contents
0	Linear count
1	Ring count

2. Pulse input types (channel 0: _Fxy_CH0_PLS_MODE, channel 1: _Fxy_CH1_PLS_MODE)

Setting value	Contents
0	2 phase 1 multiplier
1	2 phase 2 multiplier
2	2 phase 4 multiplier
3	CW/CCW
4	1 phase /1 input /1 multiplier
5	1 phase /1 input /2 multiplier
6	1 phase /2 input /1 multiplier
7	1 phase /2 input /2 multiplier

3. Comparison output types (channel 0: _Fxy_CH0_CP□_MODE, channel 1: _Fxy_CH1_CP□_MODE)

Setting value	Contents
0	In case of current count value < comparison reference value, OUT□ is On
1	In case of current count value ≤ comparison reference value, OUT□ is On
2	In case of current count value = comparison reference value, OUT□ is On
3	In case of current count value ≥ comparison reference value, OUT□ is On
4	In case of current count value > comparison reference value, OUT□ is On
5	In case of comparison minimum value ≤ current count value ≤ comparison maximum value, OUT□ is On
6	In case of comparison minimum value ≥ current count value, current count value ≤ comparison maximum value, OUT□ is On

※ Here, □ means 0 or 1.

4. Additional function types (channel 0: _Fxy_CH0_AUX_MODE, channel 1: _Fxy_CH1_AUX_MODE)

Setting value	Contents
0	Not used
1	Count clear
2	Count latch
3	Sampling count
4	Input frequency measure
5	Revolution measure per unit time
6	Count disable

5. The frequency display unit of input frequency measure

(channel 0: `Fxy_CH0_FREQ_MODE`, channel 1: `_Fxy_CH1_FREQ_MODE`)

Setting value	Contents
0	1Hz
1	10Hz
2	100Hz
3	1000Hz(=1kHz)

6. The status of comparison output during operation mode of XGI CPU module is stop mode.

(channel 0, channel 1: `Fxy_PLCSTOP_OUT_EN`)

Setting value	Contents
0	Output disable
1	Output preservation

6.2 Global Variable

1. The range of output data

Channel 0	Channel 1	Contents
_xy_CH0_CNT	_xy_CH1_CNT	Current count value
_xy_CH0_FRQ	_xy_CH1_FRQ	Count latch
_xy_CH0_LTH	_xy_CH1_LTH	Sampling count
_xy_CH0_RNG	_xy_CH1_RNG	Input frequency count
_xy_CH0_RPU	_xy_CH1_RPU	Revolution per unit time

Remark

- (1) Here, 'x' means the base number which the high speed counter module is mounted, and 'y' means the slot number of it.
- (2) It is double word (dword) to the data type of the range of output data.

2. The display of operation status and the range of operation command

Channel	Output (CPU Module ← High speed counter)		Input (CPU Module → High speed counter)	
	Status	Contents	Command	Contents
Channel0	_xy_CH0_DN	Count Up/Down status	_xy_CH0_CNTEN	Count enable (level)
	_xy_CH0_EXTPRE	Input detection of external preset	_xy_CH0_PREEN	Preset enable (edge)
	_xy_CH0_CRY	Carry detection	_xy_CH0_DWNCNT	Up/Down count selection (level)
	_xy_CH0_BRW	Borrow detection	_xy_CH0_AUXEN	Additional function enable(level/edge)
	_xy_CH0_AUXING	In operation of additional function	_xy_CH0_CMPEN	Comparison enable (level)
	_xy_CH0_CMPOUT0	The status of comparison output 0	_xy_CH0_OUTEN	Comparison output enable (level)
	_xy_CH0_CMPOUT1	The status of comparison output 1	_xy_CH0_EQ0RST	Equal (=) reset of comparison output 0 (edge)
	_xy_CH0_ERR	Error detection	_xy_CH0_EQ1RST	Equal (=) reset of comparison output 1 (edge)
	_xy_RDY	Module ready	_xy_CH0_CRTBRW_RST	Carry/Borrow reset (edge)
	-	-	_xy_CH0_EXTPST_EN	External preset selection (edge)
	-	-	_xy_CH0_EXTAUX_EN	Selection of external additional function (edge)
Channel1	-	-	_xy_CH0_EXTPST_RST	Detection reset of external preset(edge)
	_xy_CH1_DN	Count Up/Down status	_xy_CH1_CNTEN	Count enable (level)
	_xy_CH1_EXTPRE	Input detection of external preset	_xy_CH1_PREEN	Preset enable (edge)
	_xy_CH1_CRY	Carry detection	_xy_CH1_DWNCNT	Up/Down count selection (level)
	_xy_CH1_BRW	Borrow detection	_xy_CH1_AUXEN	Additional function enable(level/edge)
	_xy_CH1_AUXING	In operation of additional function	_xy_CH1_CMPEN	Comparison enable (level)
	_xy_CH1_CMPOUT0	The status of comparison output 0	_xy_CH1_OUTEN	Comparison output enable (level)
	_xy_CH1_CMPOUT1	The status of comparison output 1	_xy_CH1_EQ0RST	Equal (=) reset of comparison output 0 (edge)
	_xy_CH1_ERR	Error detection	_xy_CH1_EQ1RST	Equal (=) reset of comparison output 1 (edge)
	-	-	_xy_CH1_CRTBRW_RST	Carry/Borrow reset (edge)
	-	-	_xy_CH1_EXTPST_EN	External preset selection (edge)
-	-	_xy_CH1_EXTAUX_EN	Selection of external additional function (edge)	
-	-	_xy_CH1_EXTPST_RST	Detection reset of external preset(edge)	

Remark

It is bool type to the data type of the display of operation status and the range of operation command.

Chapter 7 Programming

Here describes how to program by using instruction (XGK series) or function block (XGI/XGR) at scan program of XG5000

7.1 Instruction and Function Block

Here describes instruction and function block to read and write data of HSC module at XGT CPU module.

Remark

There is difference on terminology used in XGK series and XGI/XGR series. The following table indicates the relation of terminology used in HSC module.



XGK series	XGI/XGR series
Instruction	Function Block
Internal memory	Global constant
I/O signal (U device)	Global variable
Device	Variable
F area	Flag

7.1.1 Instruction of XGK series

1. GET/GETP instruction

It is an instruction used to read the details of High Speed counter module's internal memory to PLC CPU. The read data can be saved on PLC CPU memory (except F area).

(1) Operation of GET/GETP instruction

GET	Always executed with execution condition On ()	Level
GETP	Executed with execution condition of operation start ()	Edge

(2) Configuration of GET/GETP Instruction

Execution condition

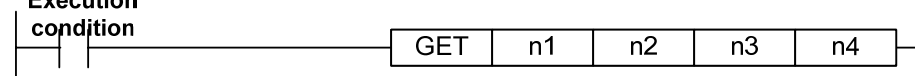

Type	Description	Area Available	Type
n1	Slot No. the special module is installed on	Integer	Hexadecimal is recommended
n2	Start address of special module's operation parameters setting area to read data	Integer	
n3	Device's start address with saved data to read	M, P, K, L, T, C, D, #D	
n4	Number of words data to read	Integer	

Chapter 7 Program

(a) How to set base and slot number

1) Basic base

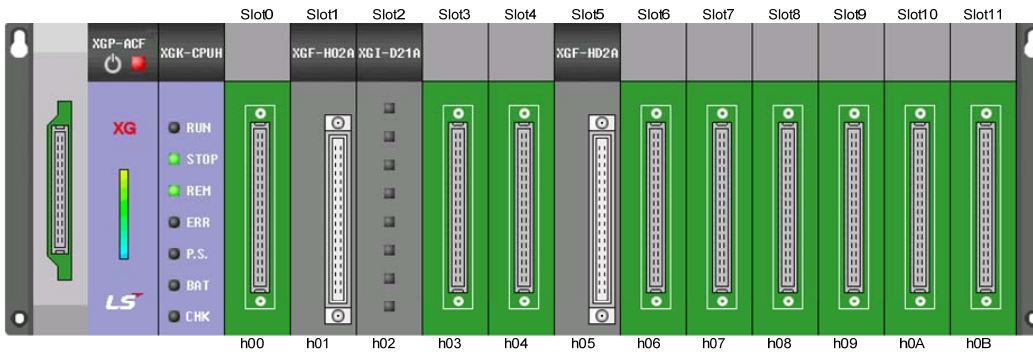

2) Extension base

a) Extension base stage 1

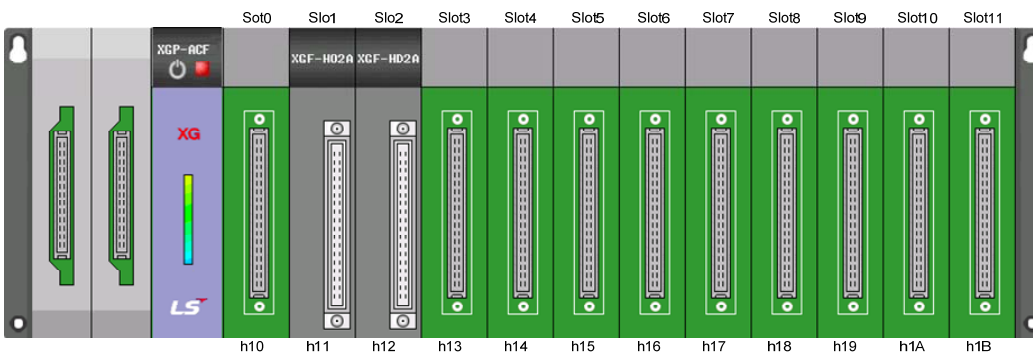

b) Extension base stage 2

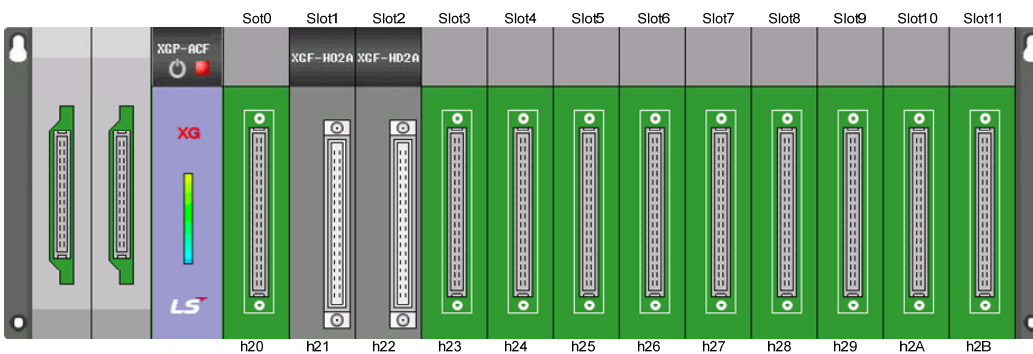

(3) Use of GET/GETP instruction

(a) HSC module is installed at slot 8 of basic base and While M00000 is On, it transmits the data (data1, data2) of internal memory 5 and 6 to D00015 and D00016.

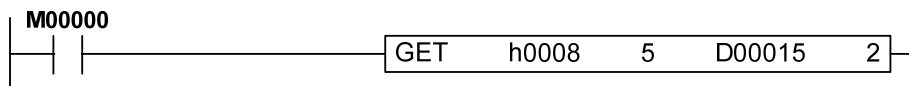
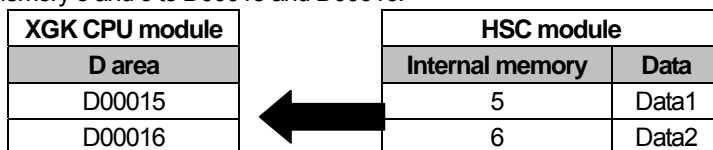

(b) It transmits data at rising edge of M00000.



(c) HSC module is installed at slot 4 of extension base stage 2. While M00001 is on, it transmits data of internal memory 10 ~ 15 to D00001 ~ D00006.

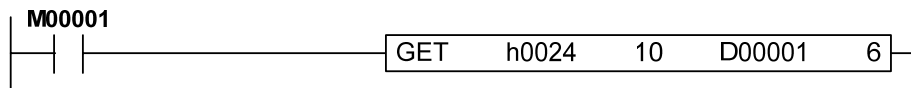
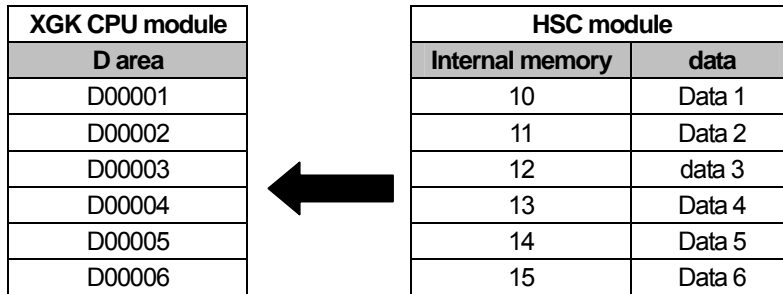

2. PUT/PUTP instruction

Instruction to write data from XGK CPU module to internal memory area

(1) PUT/PUTP instruction

PUT	Always executed with execution condition On ()	Level
PUTP	Executed with execution condition of operation Start ()	Edge

(2) Configuration of PUT/PUTP instruction

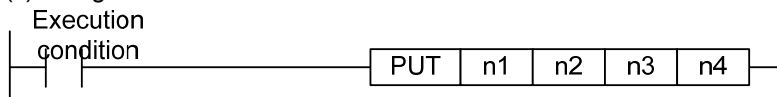

Type	Description	Available area	Reference
n1	Slot No. the special module is installed on	Integer	Hexadecimal is recommended
n2	Start address of special module's internal memory to write data.	Integer	
n3	Device's start address or integer with saved data to write.	M, P, K, L, T, C, D, #D	
n4	Number of words data to write	Integer	

(a) Base and slot number setting method

It is same with GET/GETP instruction

(3) Use of PUT/PUTP instruction

(a) HSC module is equipped at 10 slot of basic base. While M00000 is On, it transmits data of D00000 (data1) to internal memory address 1

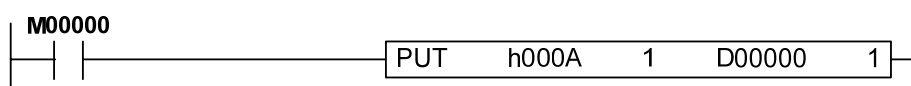
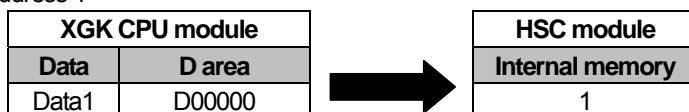

Chapter 7 Program

(b) It transmits data at the rising edge of M0000

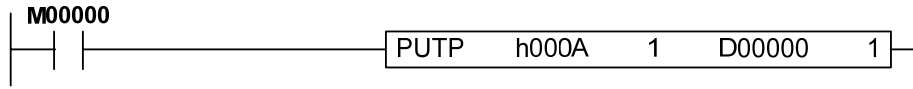

(c) HSC module is equipped at slot 0 of extension base stage 1. While M00001 is on, it transmits data D00001 ~ D00006 to internal memory address 10 ~ 15.

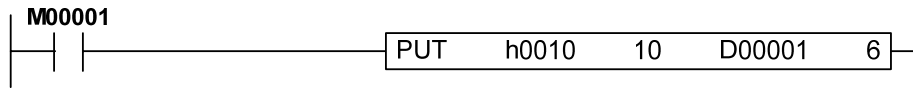
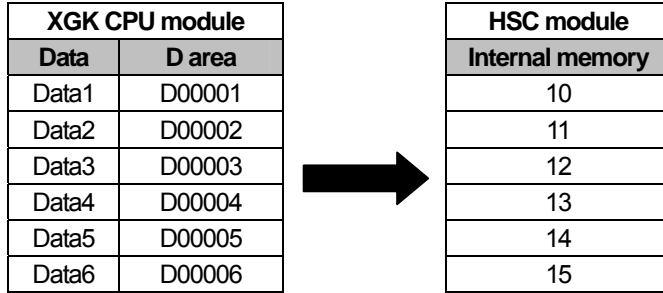

7.1.2 Function Block of XGI/XGR

1. GET function block

Function Block to read data of Global constant area at XGI/XGR CPU module. That data can be saved at variable area of XGI/XGR CPU module (Except flag area).

(1) GET function block configuration

Function block		Classification	Variable	Description
BOOL — REQ DONE — BOOL USINT — BASE STAT — UINT USINT — SLOT DATA — ### UINT — MADDR	<div style="border: 1px solid black; padding: 5px; width: fit-content; margin: 0 auto;"> GET_### </div>	Input	REQ	Request execution
			BASE	Base where HSC module is equipped
			SLOT	Slot where HSC module is equipped
			MADDR	Global constant area
		Output	DONE	Function Block execution status
			STAT	Error information
			DATA	Output data

Remark

- (1) '###' means that WORD, DWORD, INT, UINT, DINT, UDINT type is available.
- (2) For 'REQ', edge signal or level signal is available.
- (3) For 'MADDR', Global constant or integer is available.
- (4) 'Output data' is data read from Global constant.
- (5) In case of XGR, HSC module should be equipped at extension base.

Function block is classified as follows according to output variable type.

Function Block	Output variable type	Operation description
GET_WORD	WORD	Reads WORD data from Global constant area (MADDR).
GET_DWORD	DWORD	Reads DWORD data from Global constant area (MADDR).
GET_INT	INT	Reads INT data from Global constant area (MADDR).
GET_UINT	UINT	Reads UINT data from Global constant area (MADDR).
GET_DINT	DINT	Reads DINT data from Global constant area (MADDR).
GET_UDINT	UDINT	Reads UDINT data from Global constant area (MADDR).

(2) Use of GET function block

(a) HSC module is equipped at slot 8 of basic base. While 'Read1' is on, it transmits data of '_F08_CH0_CNT_MODE' to 'Output data1'

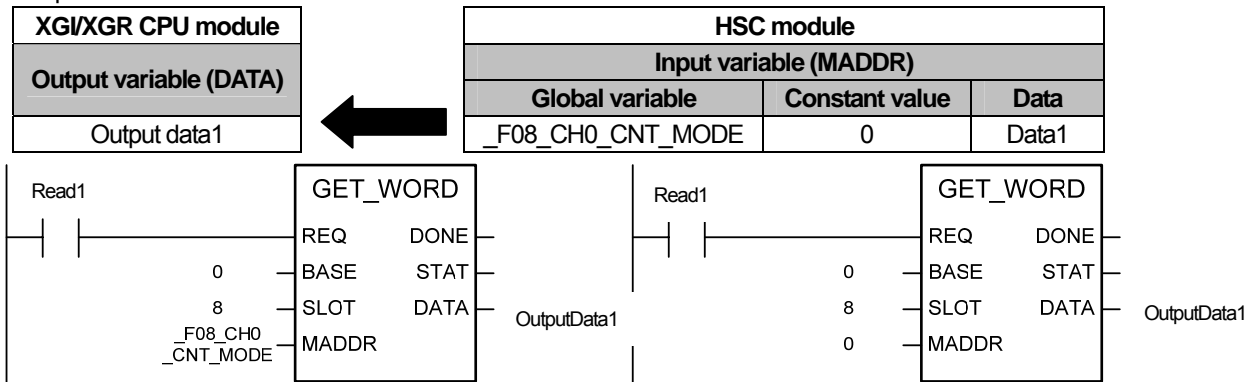

Remark

(1) Results of above two examples are same.

(2) For detail of Global variable, refer to XG5000 user manual.

(b) It transmits data at the rising edge of execution condition

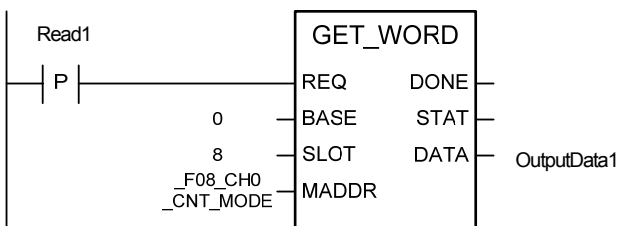

(c) HSD module is equipped at slot 4 of extension base stage 2. While 'Read2' is on, it transmits data of '_F24_CH1_CP0_MIN' to 'OutputData2'.

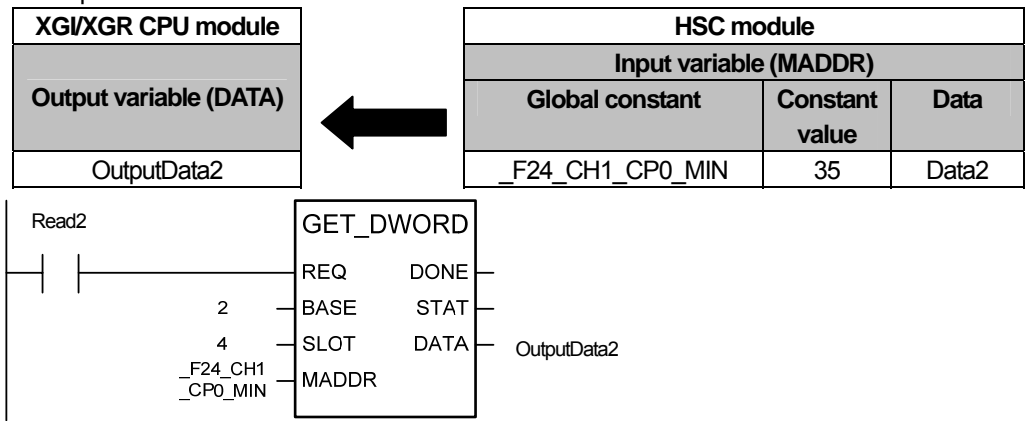

Chapter 7 Program

2. PUT function block

Function Block to write the data into Global constant area at XGI/XGR CPU module.

(1) Configuration of PUT function block

Function Block		classification	Variable	Description
BOOL — REQ DONE — BOOL USINT — BASE STAT — UINT USINT — SLOT UINT — MADDR ### — DATA	PUT_###	Input	REQ	Request execution
			BASE	Base where HSC module is equipped
			SLOT	Slot where HSC module is equipped
			MADDR	Global constant area
			DATA	Input data
		Output	DONE	Function block execution status
			STAT	Error information

Remark

- (1) '###' means that WORD, DWORD, INT, UINT, DINT, UDINT type is available.
- (2) For 'REQ', edge signal or level signal is available.
- (3) For 'MADDR', Global constant or integer is available.
- (4) 'Output data' is data read from Global constant.
- (5) In case of XGR, HSC module should be equipped at extension base.

Function block is classified as follows according to output variable type.

Function block	Input variable type	Operation description
PUT_WORD	WORD	Writes WORD data to Global constant area (MADDR).
PUT_DWORD	DWORD	Writes DWORD data to Global constant area (MADDR).
PUT_INT	INT	Writes INT data to Global constant area (MADDR).
PUT_UINT	UINT	Writes UINT data to Global constant area (MADDR).
PUT_DINT	DINT	Writes DINT data to Global constant area (MADDR).
PUT_UDINT	UDINT	Writes UDINT data to Global constant area (MADDR).

(2) Use of PUT function block

- (a) HSC module is equipped at slot 10 of basic base. While 'Write1' is on, it transmits data (Data1) of 'InputData1' to '_FOA_CH0_CNT_MODE'.

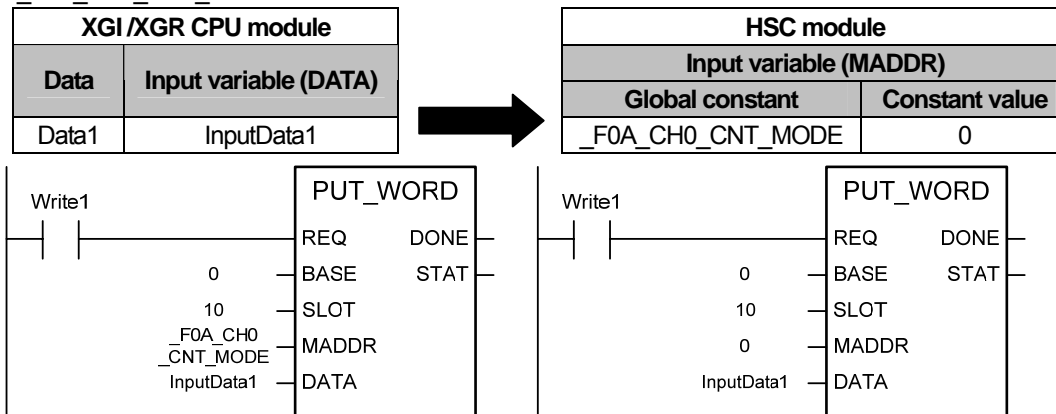

Remark

- (1) Operations of above two examples are same.
- (2) For detail of Global variable, refer to 'XG5000 user manual'.

(b) It transmits data at the rising edge of execution condition

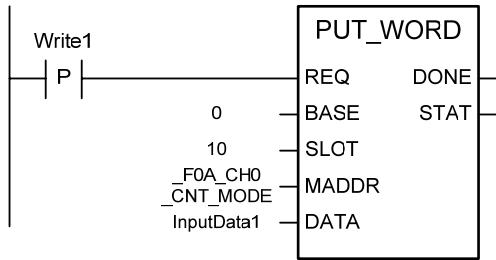

(c) HSC module is equipped at slot 6 of extension base stage 1. While 'Write2' is on, it transmits data (Data2) of 'InputData2' to '_F16_CH0_PRESET'.

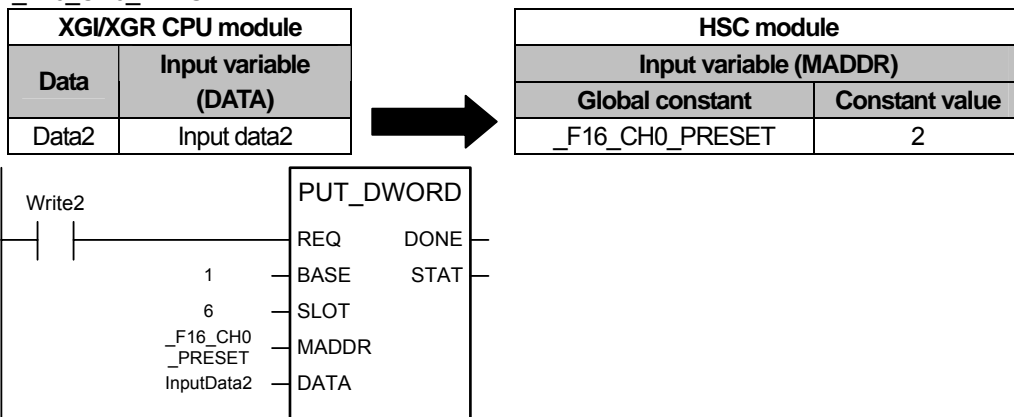

7.2 Program

1. XGK, XGI system is explained referring to the following system HSC module is equipped at slot 1 of basic base.
2. XGR system is explained referring to the following system HSC module is equipped at slot of extension base.

XGK series system

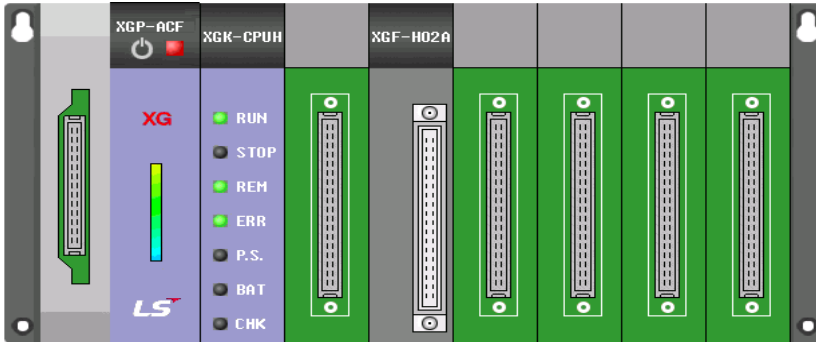

XGI series system

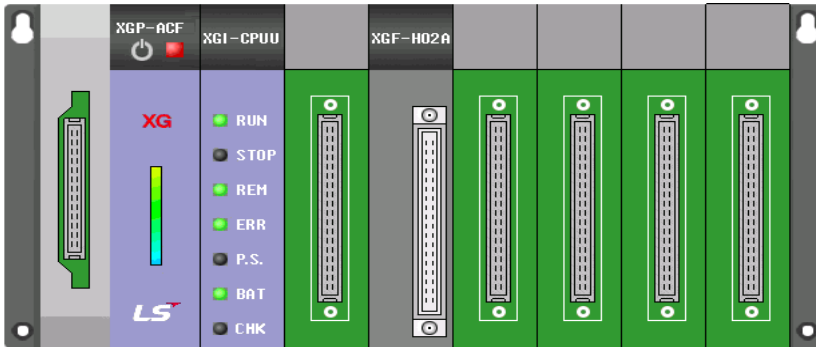

XGR series system

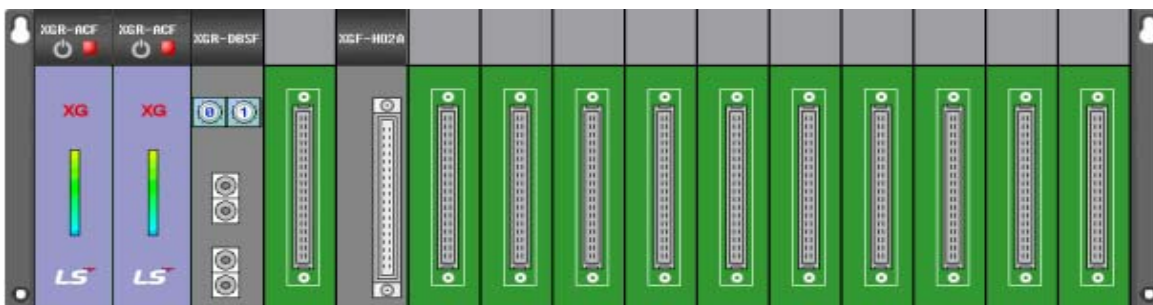
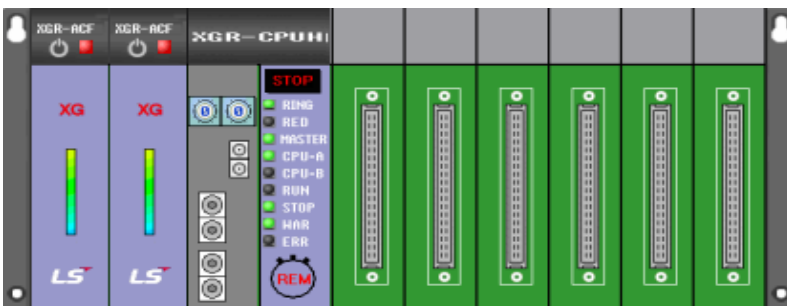

7.2.1 Count mode setting

Example explaining how to set Ring Count Min. and Max. As for setting method by 'I/O Parameter', refer to Chapter 4.

1. Setting content

Parameter	CH0	CH1
Count mode	1: Ring counter	1: Ring counter
Ring counter min.	0	0
Ring counter max.	100000	100000

2. Program

(1) Scan program of XGK series

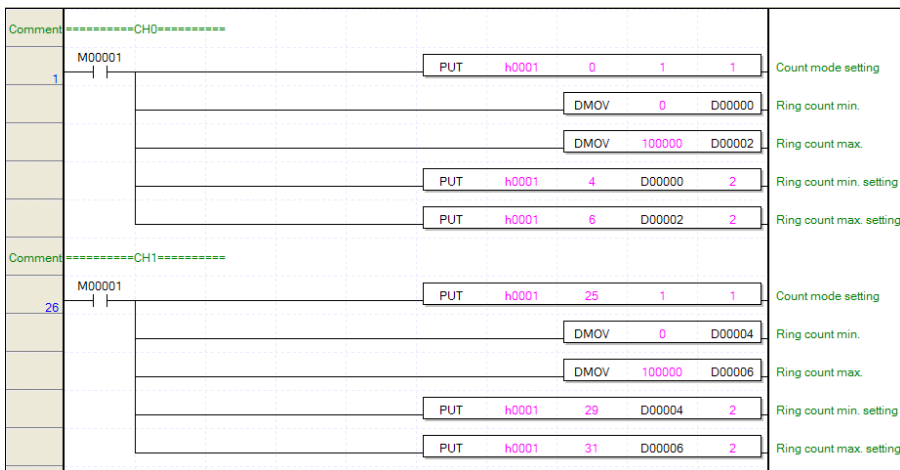

(2) Scan program of XGI/XGR series

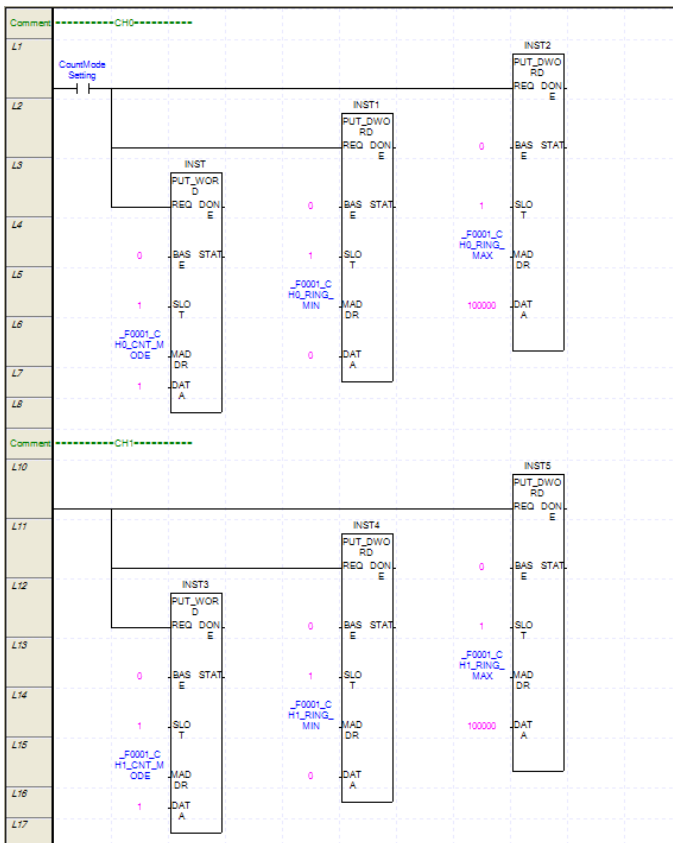

Chapter 7 Program

Remark

- (1) Since instruction PUT (Function Block PUT_DWORD) is used at scan program example of XGK (XGI/XGR) series, while input contact point is On, data is transmitted into HSC module. So, if data is changed, it is transmitted into HSC module automatically.
- (2) If you program as follows, its operation become different with program example.

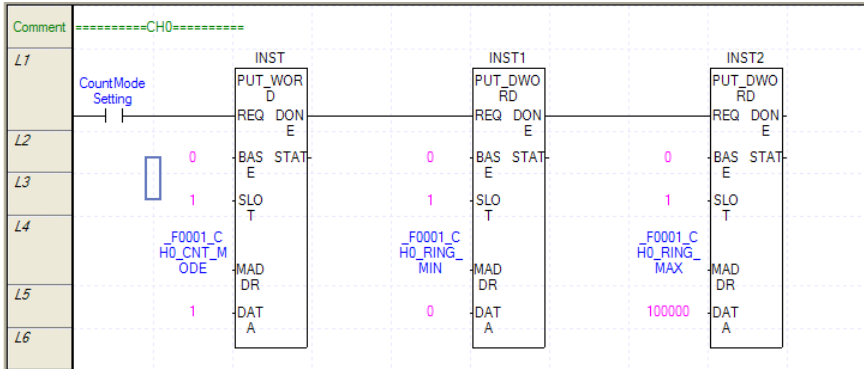

- (a) If input contact point of function block is on and execution of function block is complete, 'DONE' becomes 1. Namely, front function block and back function block are not executed simultaneously and from left to right, they are executed sequentially.
- (b) If input variable of function block is set uncorrectly and error occurs, 'DONE' doesn't become 1. Namely, if error occurs at front function block, back function block is not executed.
- (3) Integer can be inserted into 'MADDR' instead of global constant. The operation of the following program is same with that of the front example.

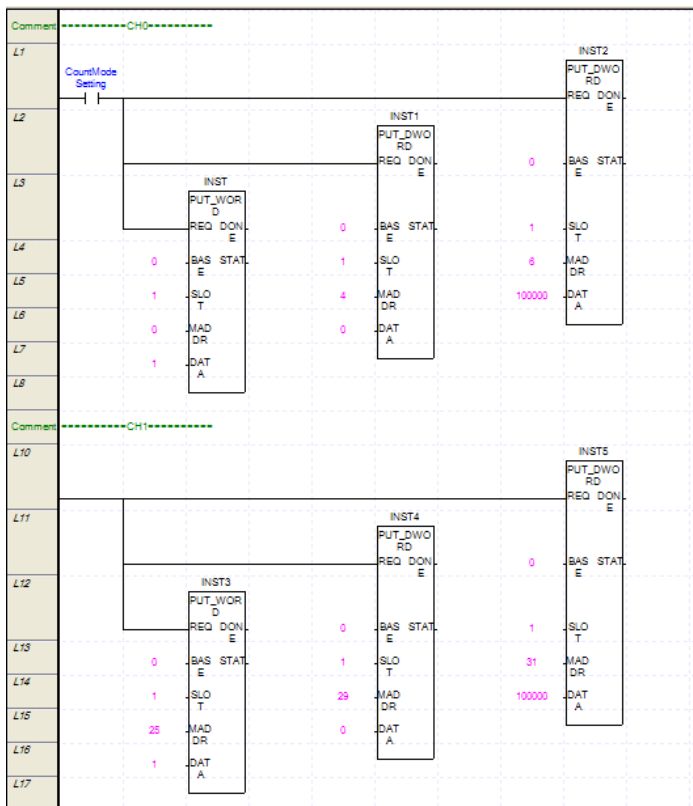

- (a) For integer corresponding to global constant, refer to Chapter 6.
- (b) On the next program example, scan program example using integer (constant) is omitted.

7.2.2 Pulse input mode setting

Program example setting pulse input mode

1. Setting contents

Parameter	CH0	CH1
Pulse input mode	3: CW/CCW	3: CW/CCW

2. Program

(1) Scan program of XGK series

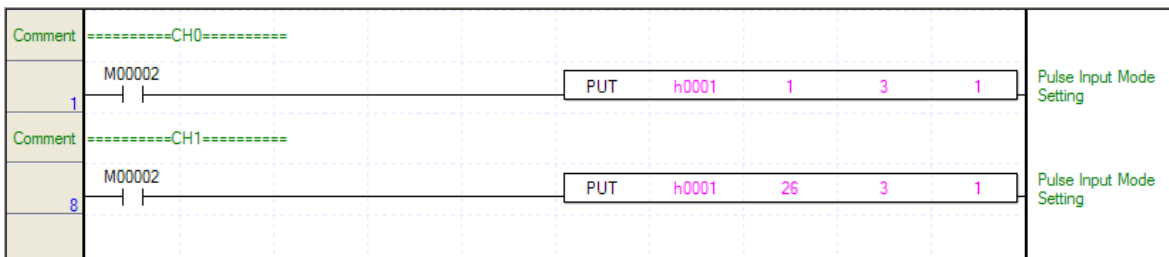

(2) Scan program of XGI/XGR series

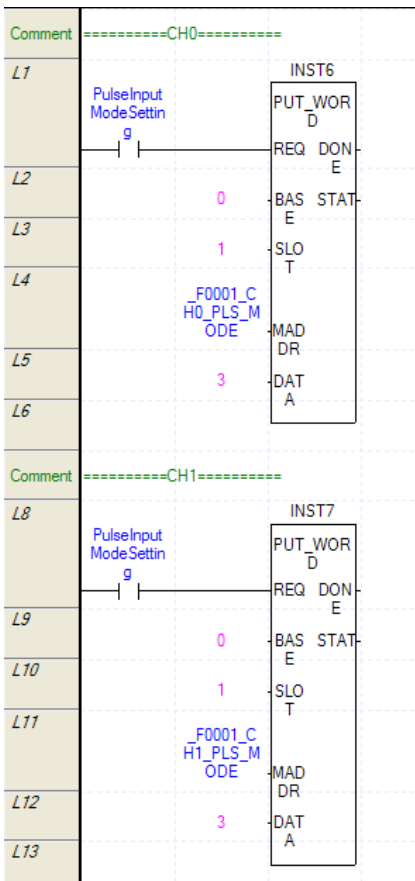

Chapter 7 Program

7.2.3 Counter check

Program example checking current counter and operation by auxiliary function.

1. Program

(1) Scan program of XGK series

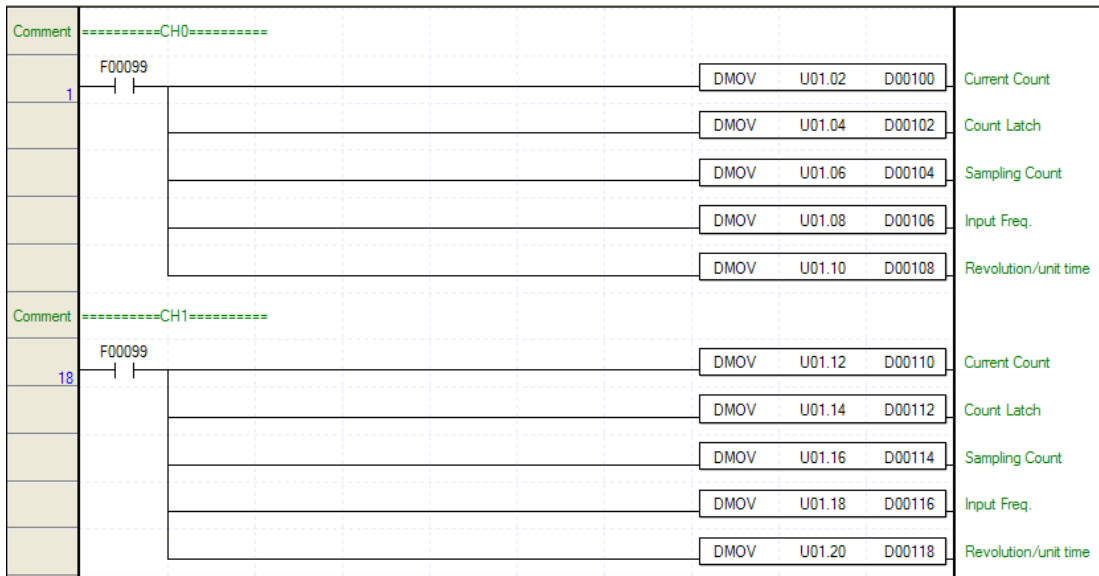

(2) Scan program of XGI/XGR series

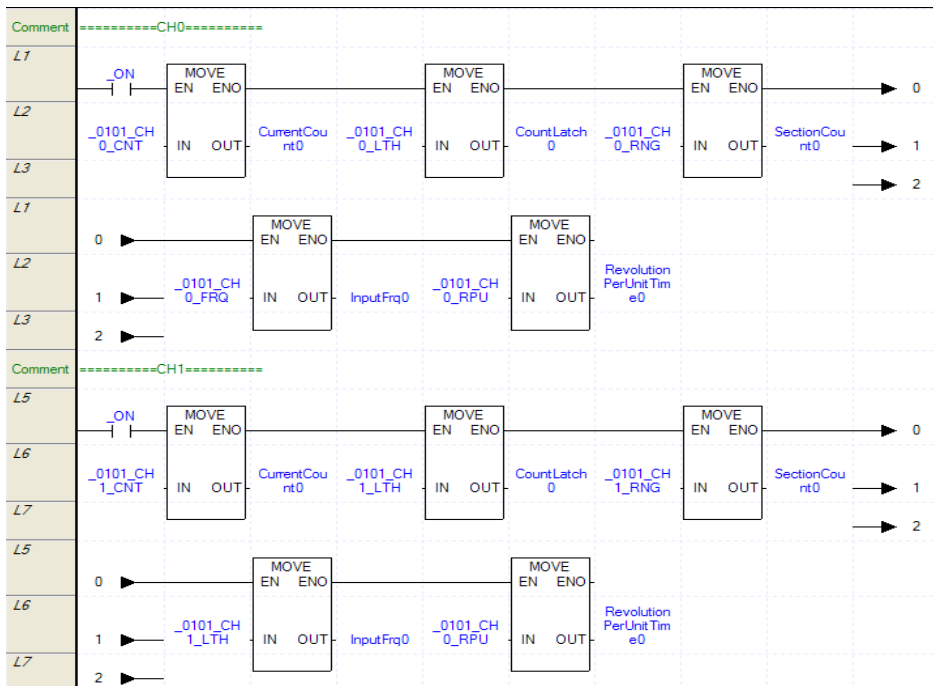

Remark

In Scan program of XGI/XGR, the number of cell is changed by using icon  or 'Change Columns' of 'View'

7.2.4 Preset value setting and enable preset

Program example about how to set preset value and enable preset

1. Setting content

Parameter	CH0	CH1
Preset value	1000	1000

2. Program

(1) Scan program of XGK series

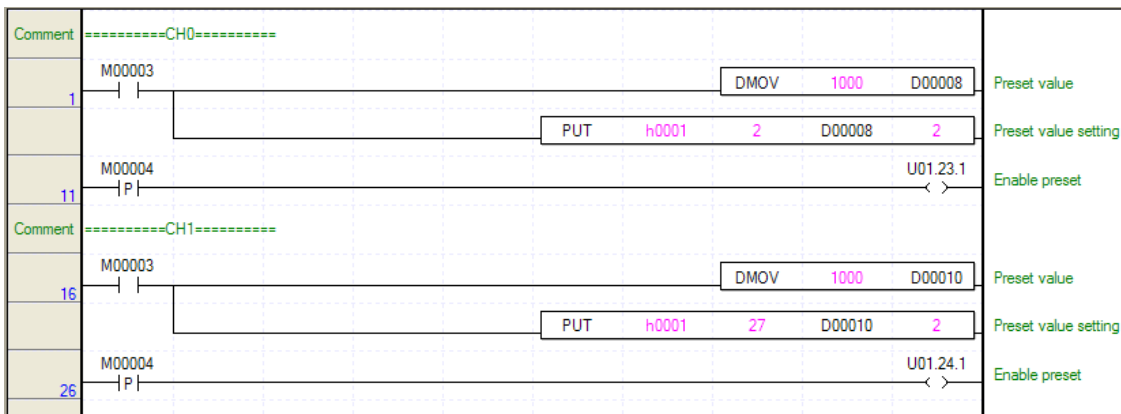

(2) Scan program of XGI/XGR

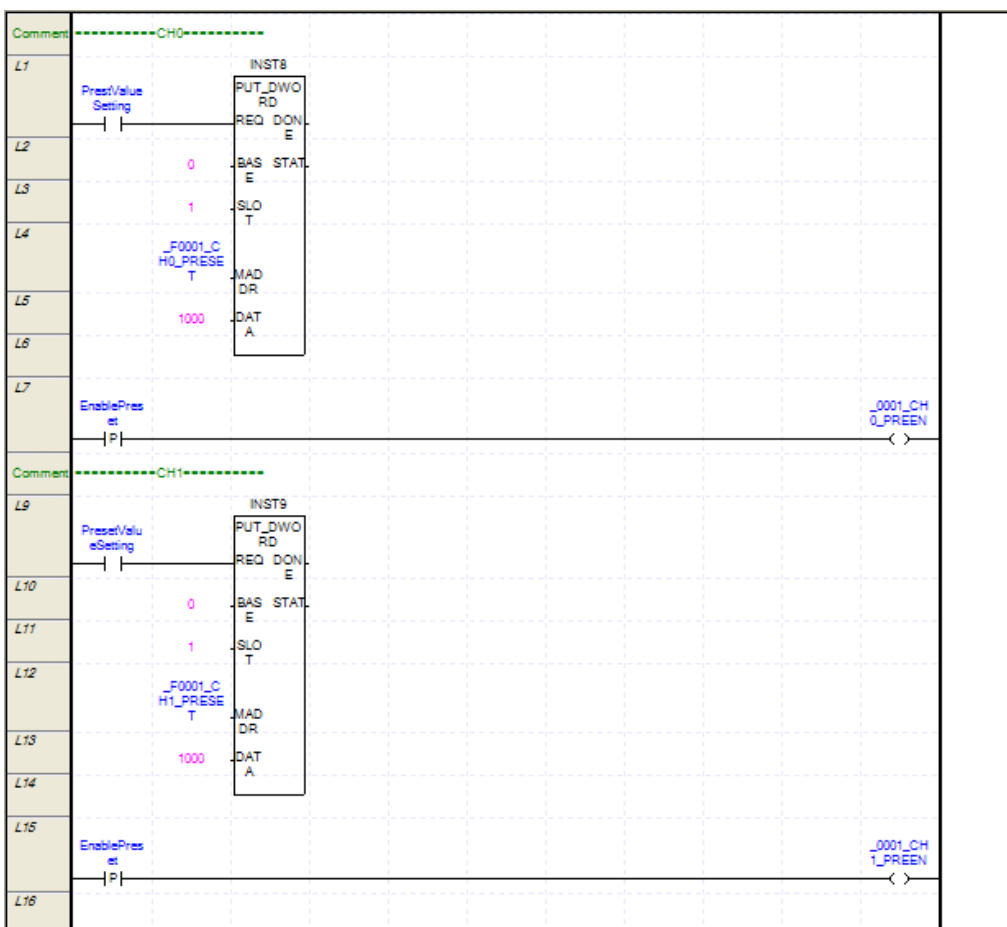

Chapter 7 Program

7.2.5 Enable counter

Program example executing Enable counter

1. Program

(1) Scan program of XGK series

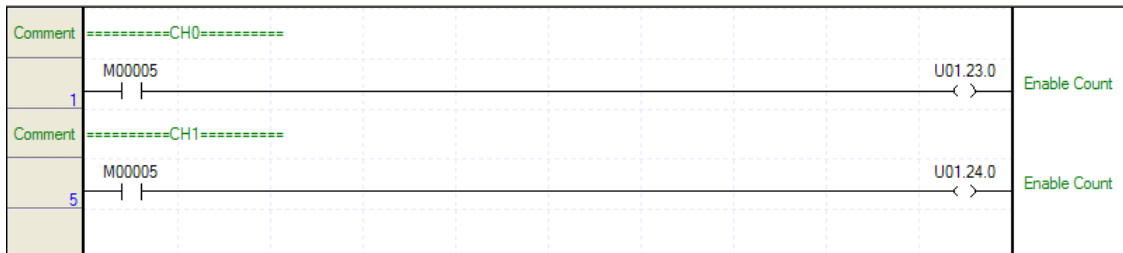

(2) Scan program of XGI/XGR series

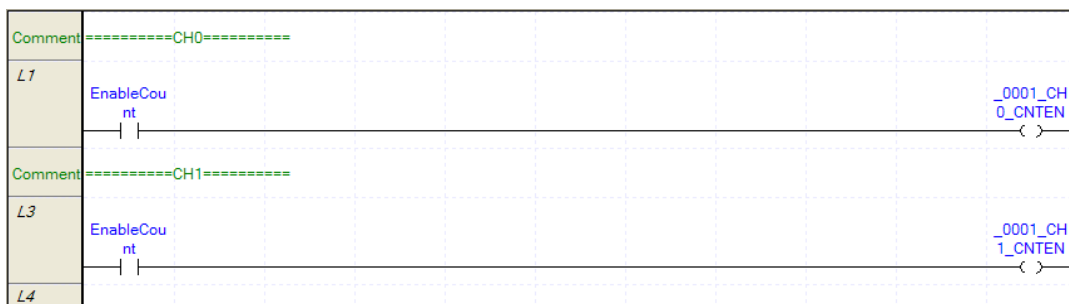

7.2.6 Carry/borrow detection reset

Program example resetting the detected carry/borrow signal

1. Program

(1) Scan program of XGK series

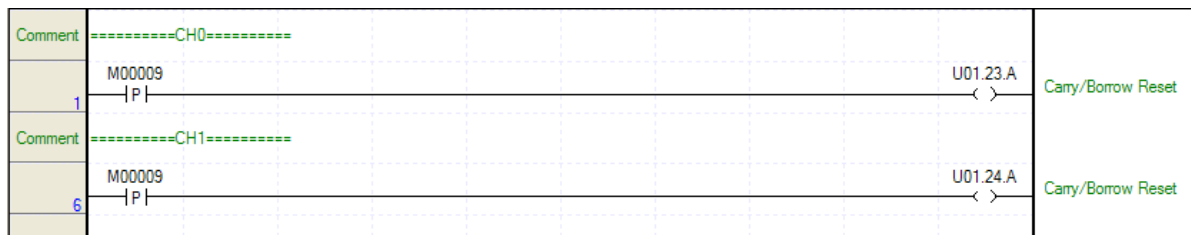

(2) Scan program of XGI/XGR series

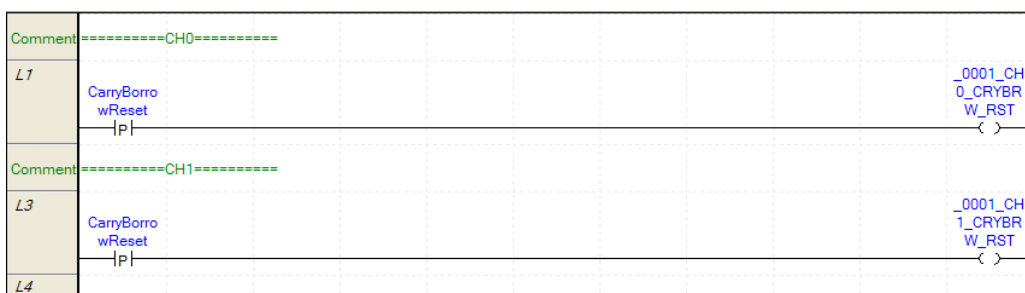

7.2.7 Auxiliary mode setting and Enable auxiliary function

Program example setting auxiliary mode and executing Enable auxiliary function. You can check the operation result of auxiliary function at 7.2.3 Counter check.

1. Counter Clear

When auxiliary function is on, change current counter as 0.

(1) Setting contents

Parameter	CH0	CH1
Auxiliary mode	1: Counter Clear	1: Counter Clear

(2) Program

(a) Scan program of XGK series

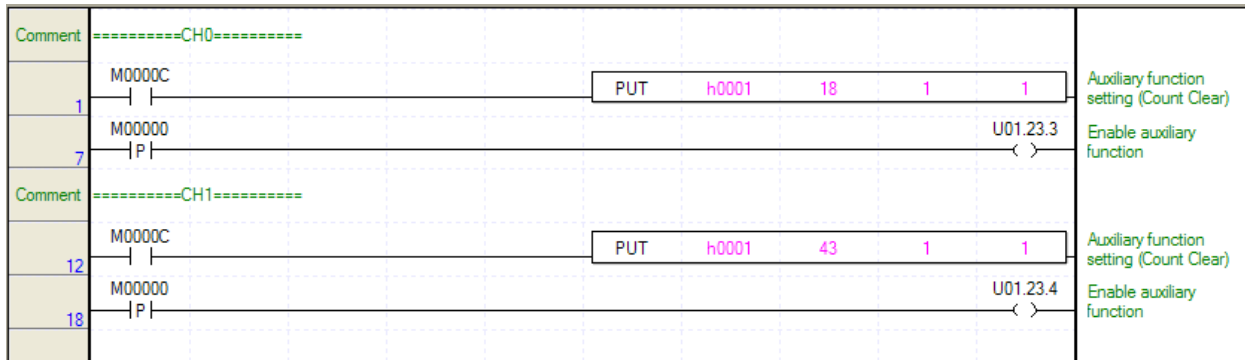

(b) Scan program of XGI/XGR

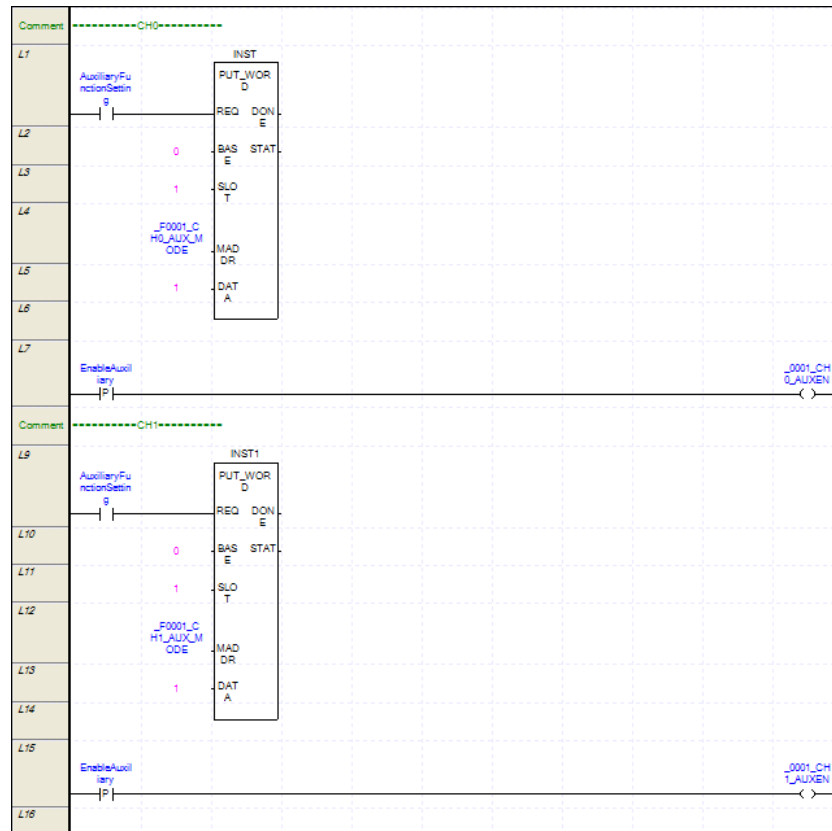

Chapter 7 Program

2. Counter latch

When Enable auxiliary is on, it indicates current counter at counter latch.

(1) Setting contents

Parameter	CH0	CH1
Auxiliary mode	2: Counter latch	2: Counter latch

(2) Program

(a) Scan program of XGK series

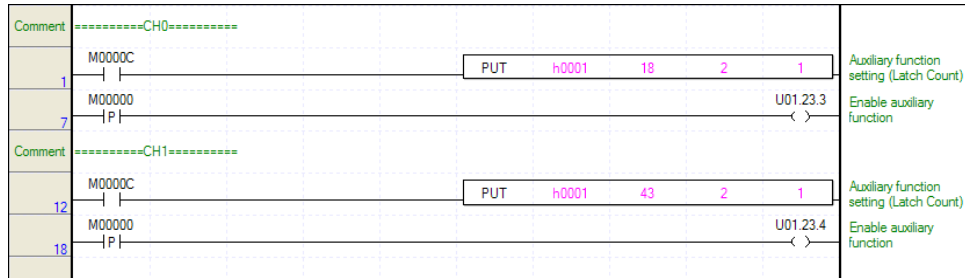

(b) Scan program of XGI/XGR series

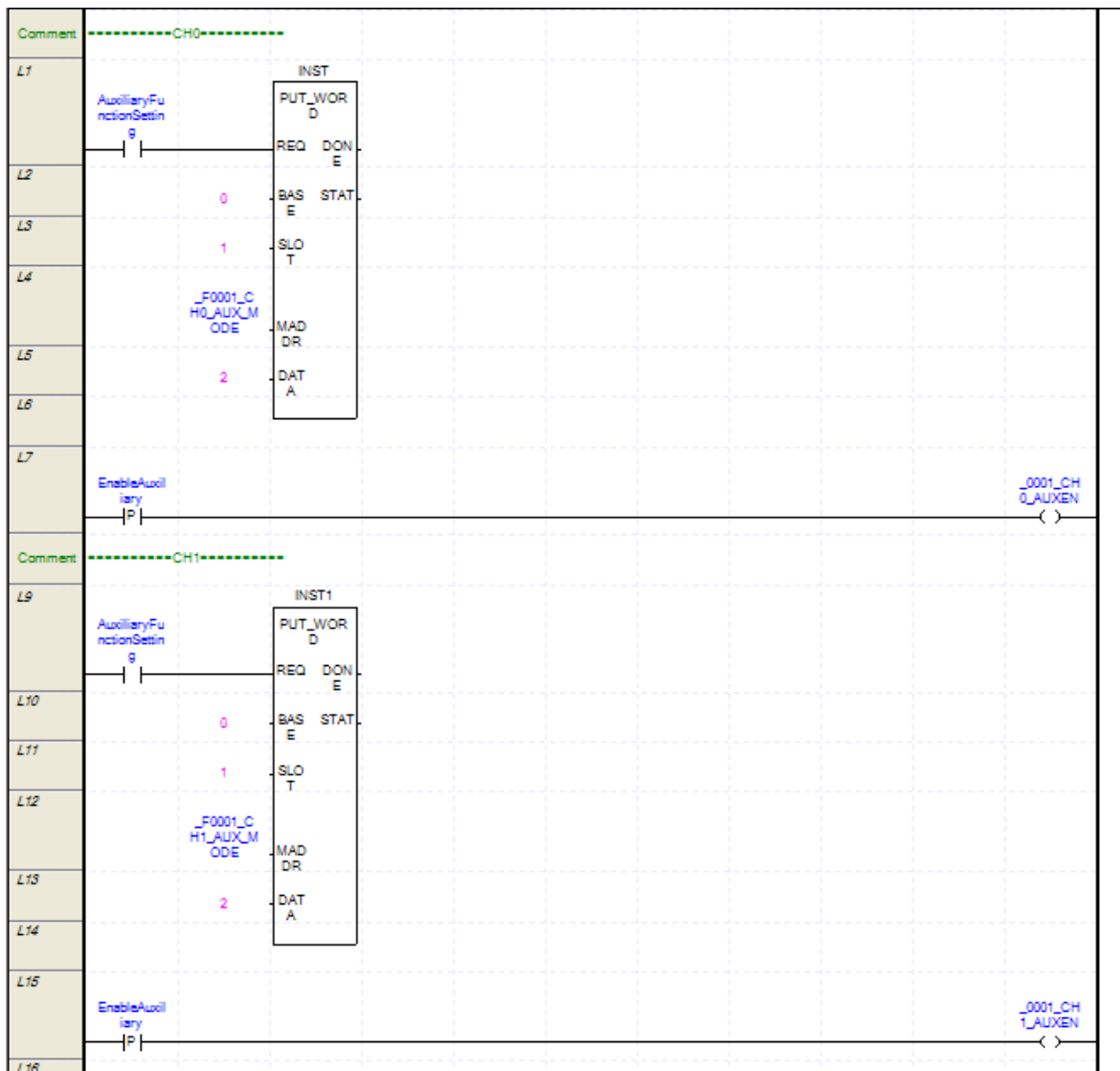

3. Sampling Count

Counter from when Enable auxiliary is on to setting time is indicated at sampling counter.

(1) Setting content

Parameter	CH0	CH1
Auxiliary mode	3: Sampling Count	3: Sampling Count
Range value	5000	5000

(2) Program

(a) Scan program of XGK series

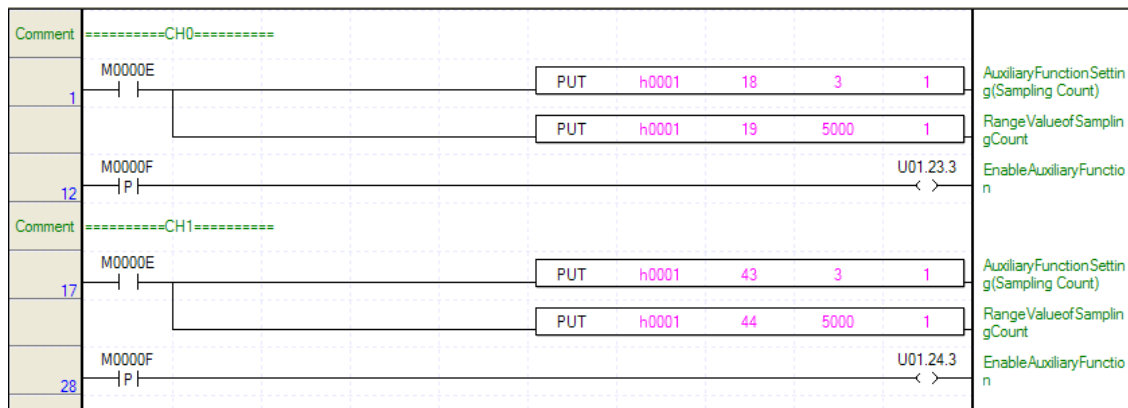

(b) Scan program of XGI/XGR series

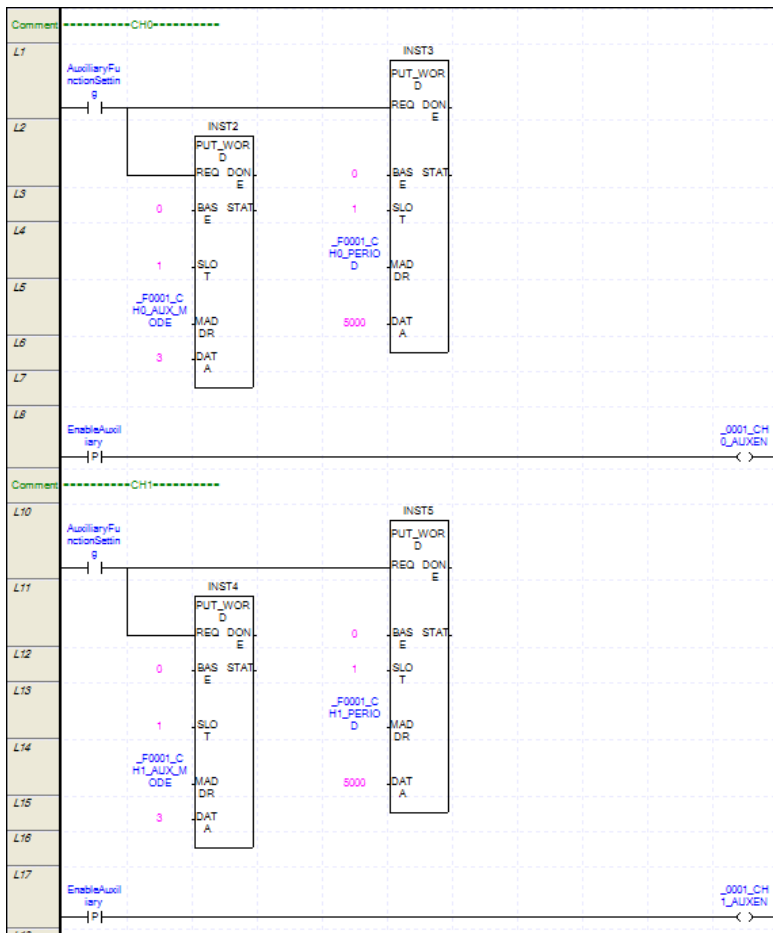

Chapter 7 Program

4. Input Freq. Measure

While Enable auxiliary function is on, input pulse is indicated at input frequency. Unit of input frequency is depending on setting of Frequency Mode.

(1) Setting content

Parameter	CH0	CH1
Auxiliary mode	4: Input Freq. measure	4: Input Freq. measure
Frequency Mode	1: 10Hz	1: 10Hz

(2) Program

(a) Scan program of XGK series

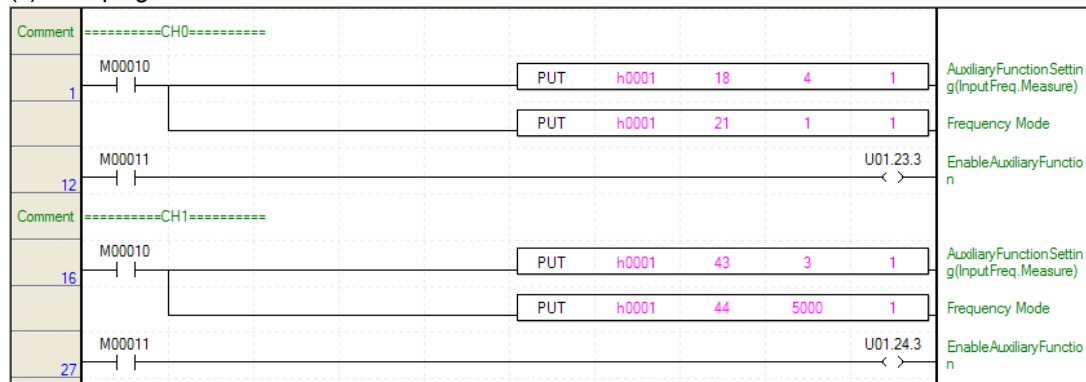

(b) Scan program of XGI/XGR series

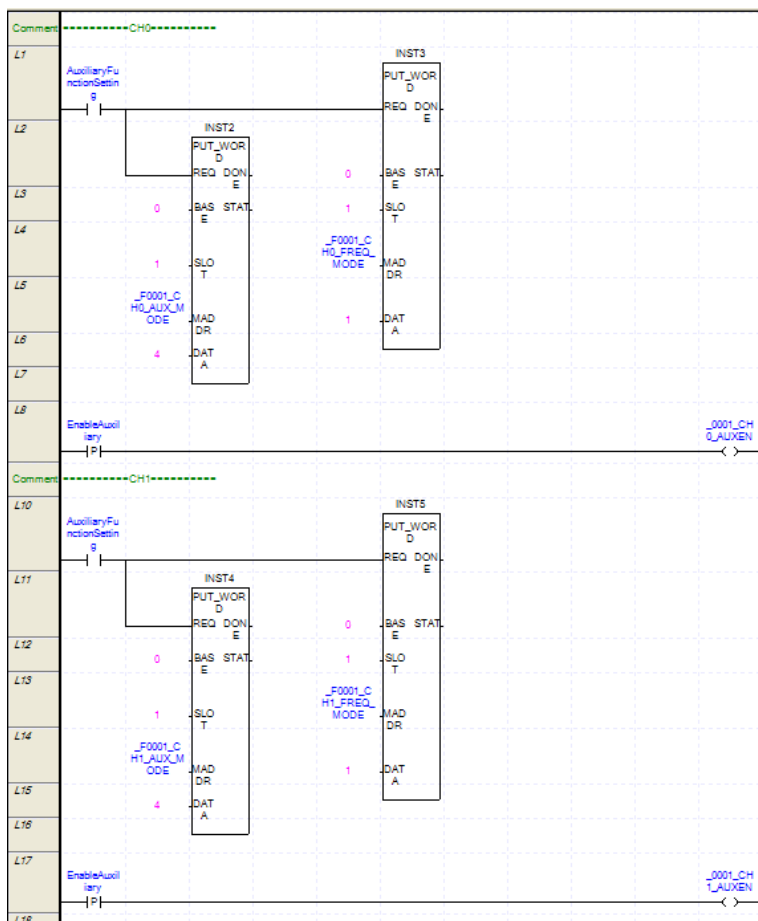

5. Revolution/Unit time

While Enable auxiliary mode is on, input pulse is calculated and indicated at revolution/unit time. For revolution/unit time, Range value and Pulse/Rev value should be set.

(1) Setting contents

Parameter	CH0	CH1
Auxiliary mode	5: Revolution/Unit time	5: Revolution/Unit time
Range value	1000	1000
Pulse/Rev value	200	200

(2) Program

(a) Scan program of XGK series

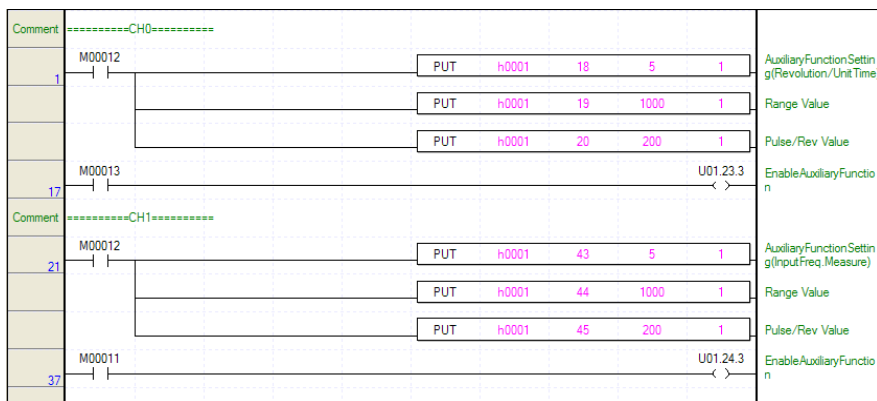

(b) Scan program of XGI/XGR series

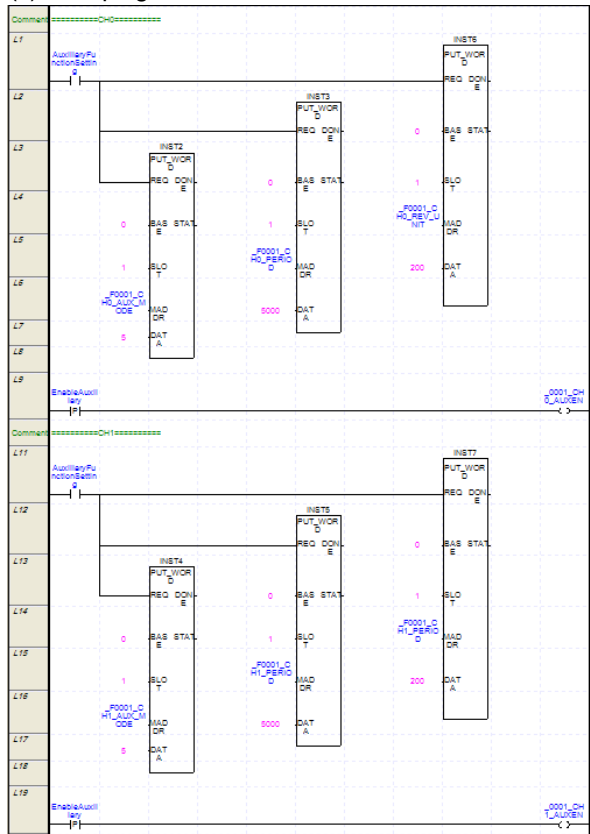

Chapter 7 Program

6. Counter Disable

While Enable auxiliary is on, counting is not executed.

(1) Setting contents

Parameter	CH0	CH1
Auxiliary mode	6: Count Disable	6: Count Disable

(2) Program

(a) Scan program of XGK series

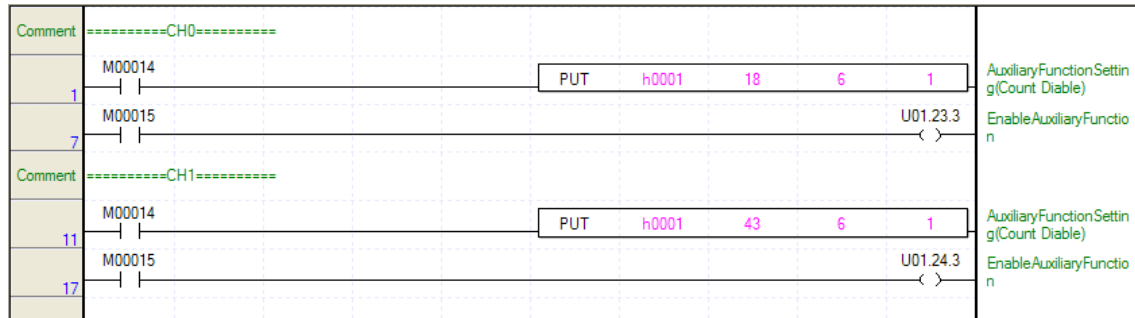

(b) Scan program of XGI/XGR series

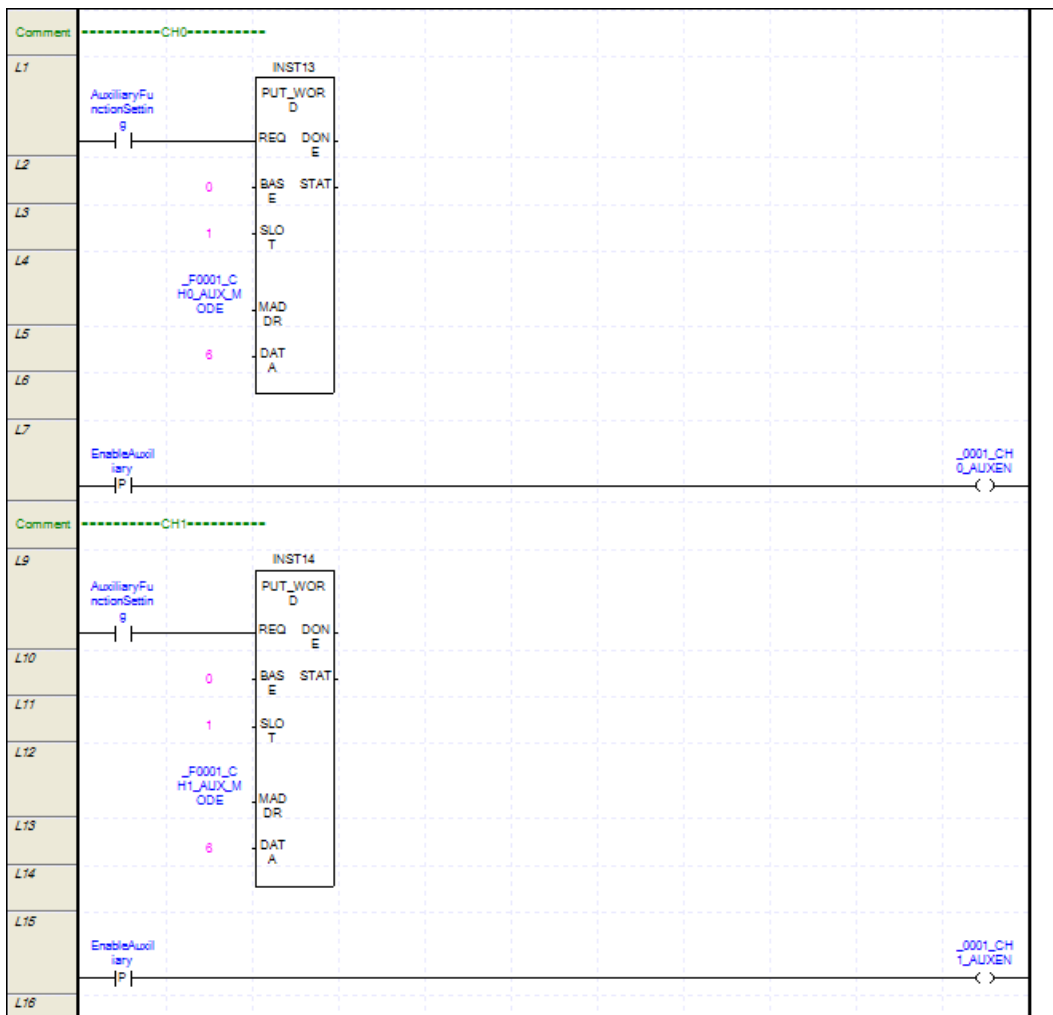

7.2.8 Up/down count selection

Program example selecting UP/Down count when input pulse is set as 1 phase 1 input 1 multiplication/2 multiplication

1. Program

(a) Scan program of XGK series

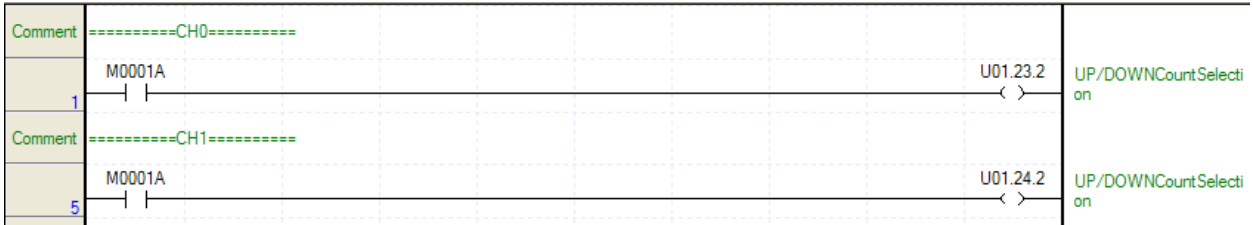

(b) Scan program of XGI/XGR series

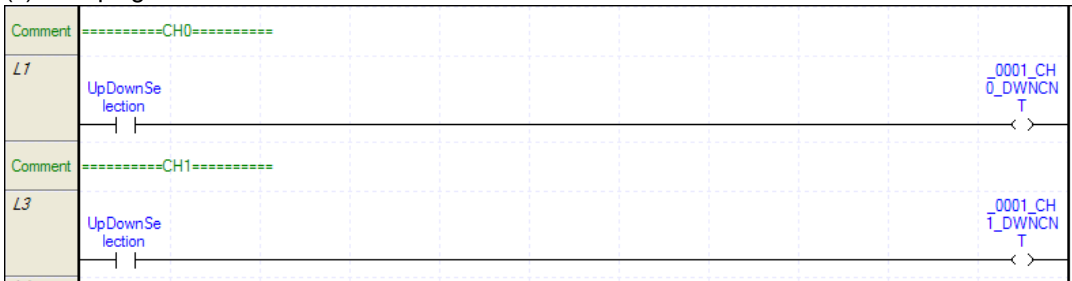

7.2.9 Use of external preset signal

Program examples allowing Enable preset by external preset signal and executing reset when external preset signal is detected

1. Program

(a) Scan program of XGK series

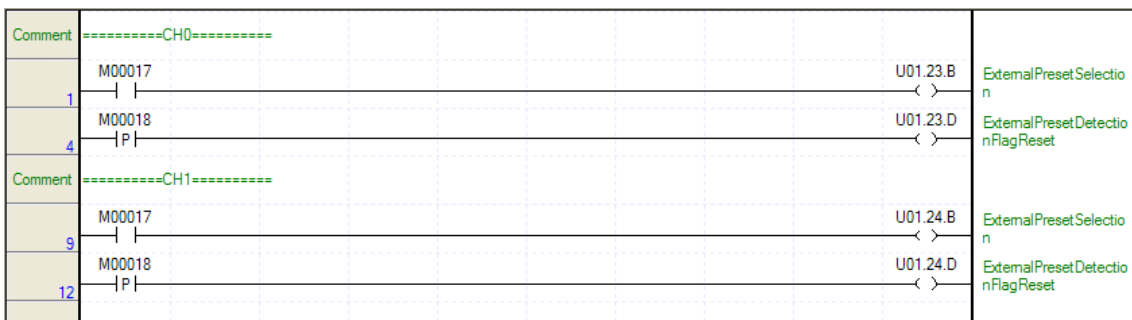

(b) Scan program of XGI/XGR series

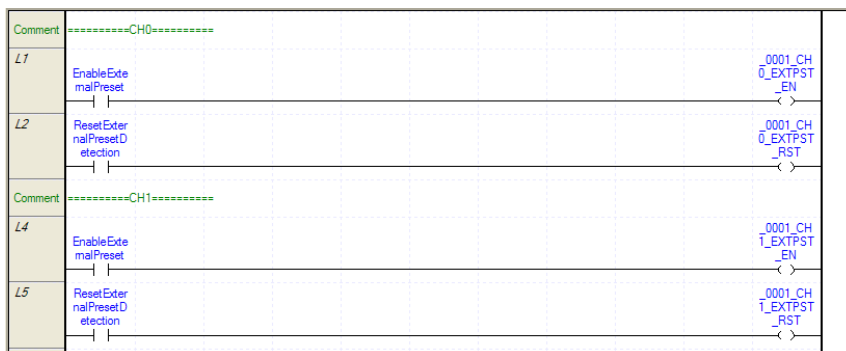

Chapter 7 Program

7.2.10 Use of external auxiliary function signal

Program example allowing Enable auxiliary function by external auxiliary function signal

1. Program

(a) Scan program of XGK series

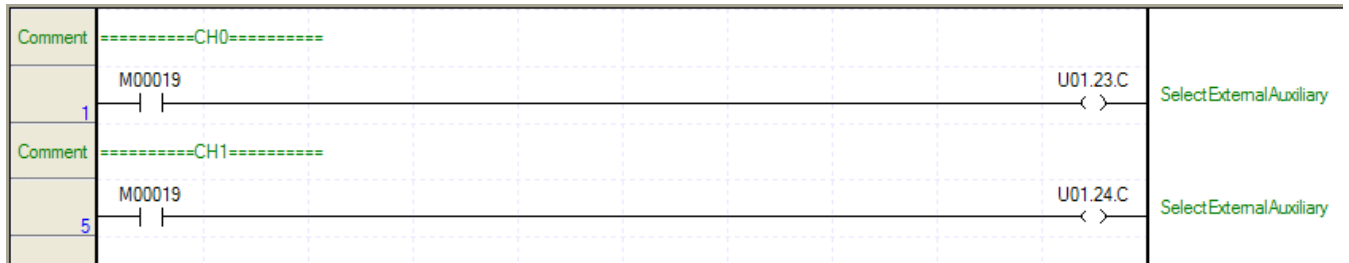

(b) Scan program of XGI/XGR series

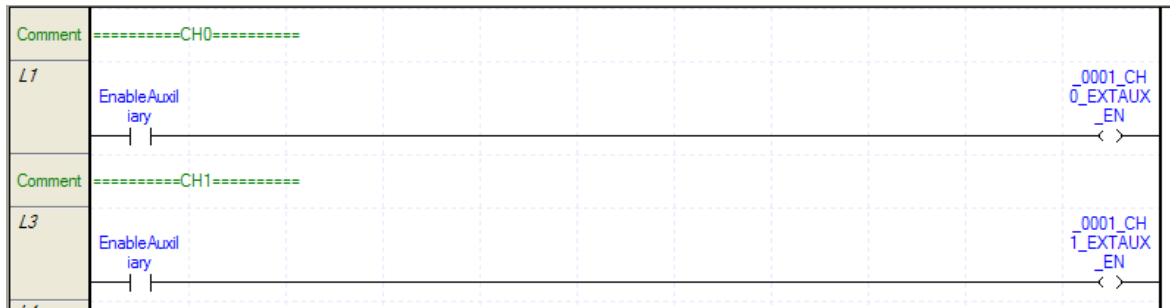

7.2.11 Type of comparison and comparison value setting

Program example explain type of comparison and comparison value setting

1. Setting content

Parameter	CH0		CH1	
	Comp output 0	Comp output 1	Comp output 0	Comp output 1
Comp output mode	1: ≤	5: ≤ ≤	1: ≤	5: ≤ ≤
Comp output min.	10	150	10	150
Comp output max.	150(No meaning)	300	150(No meaning)	300

2. Program

(a) Scan program of XGK series

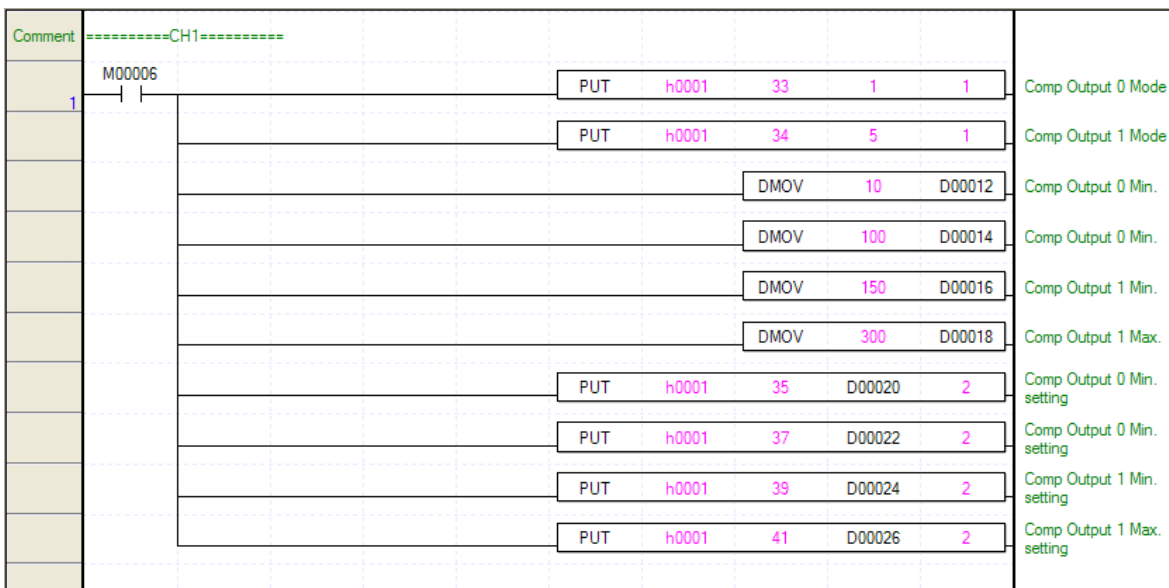
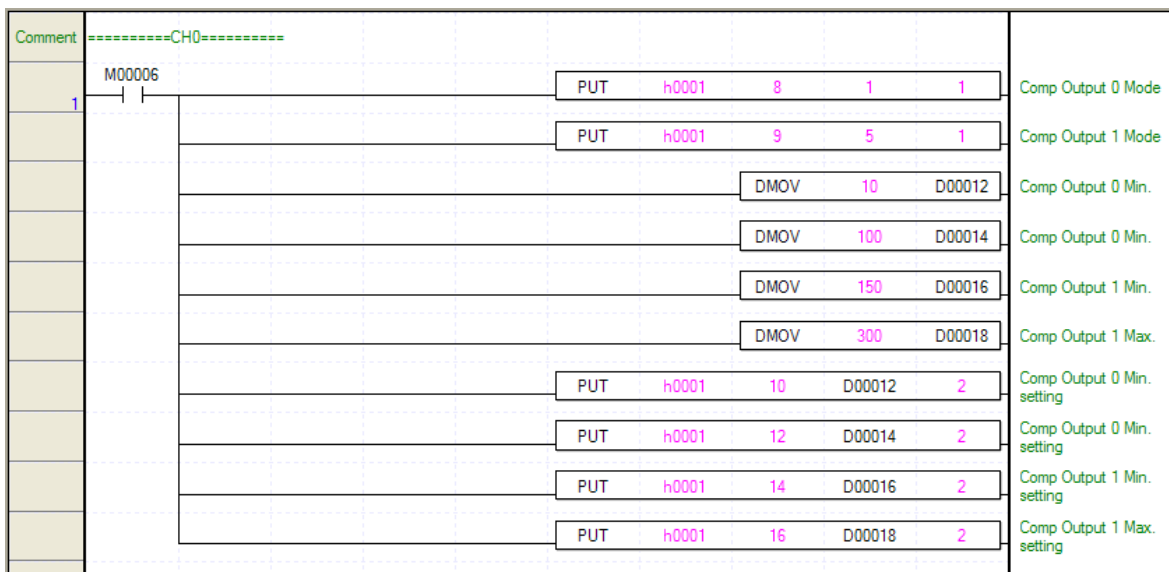

Chapter 7 Program

(b) Scan program of XGI/XGR series

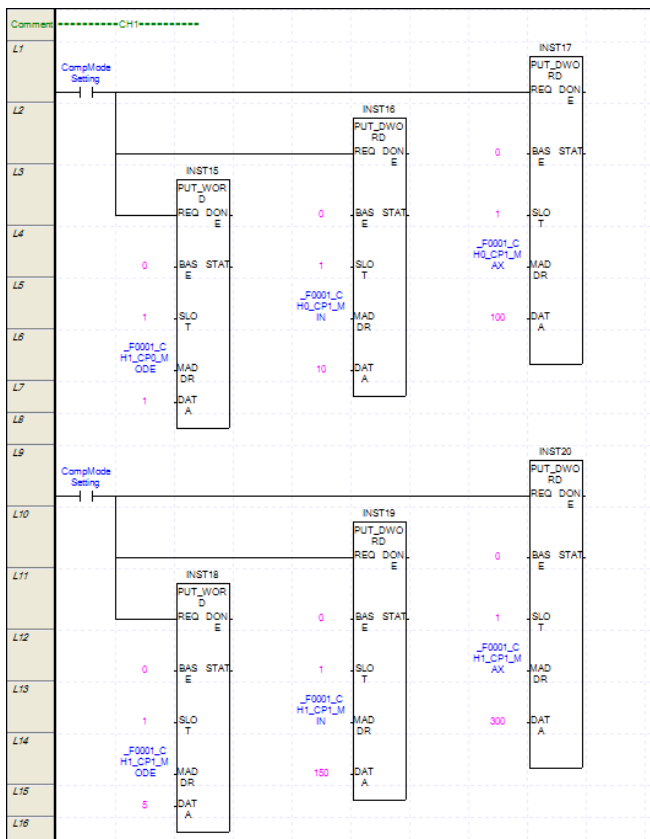
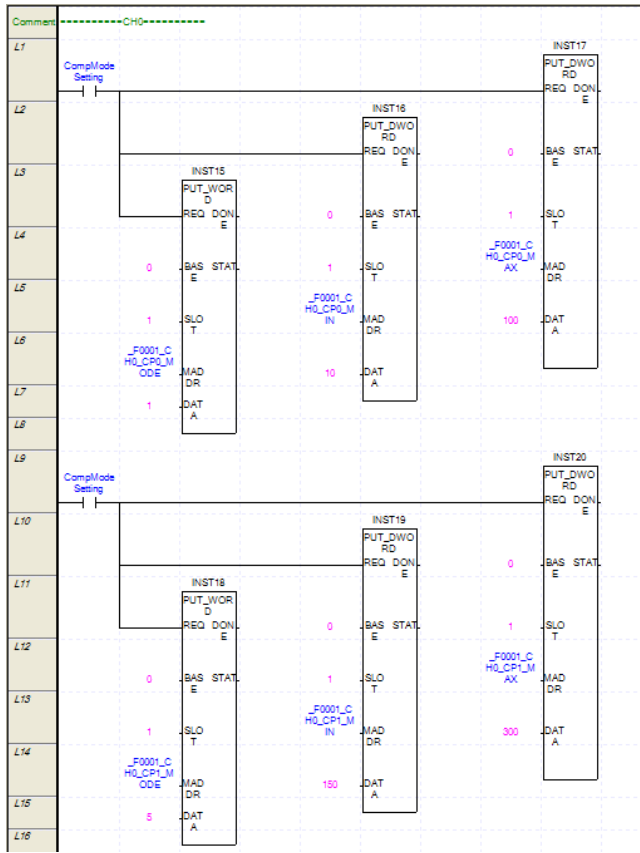

7.2.12 Enable comparison, Enable comparison output, Comparison agreement reset

Program example executing Enable comparison, Enable comparison output, Comparison agreement reset

1. Program

(a) Scan program of XGK series

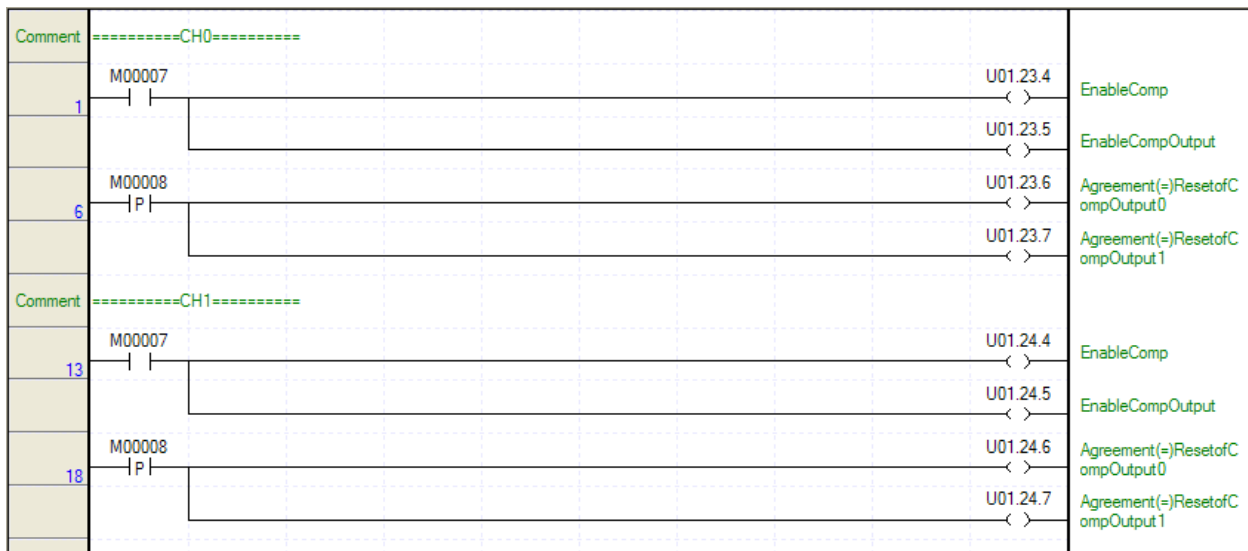

(b) Scan program of XGI/XGR series

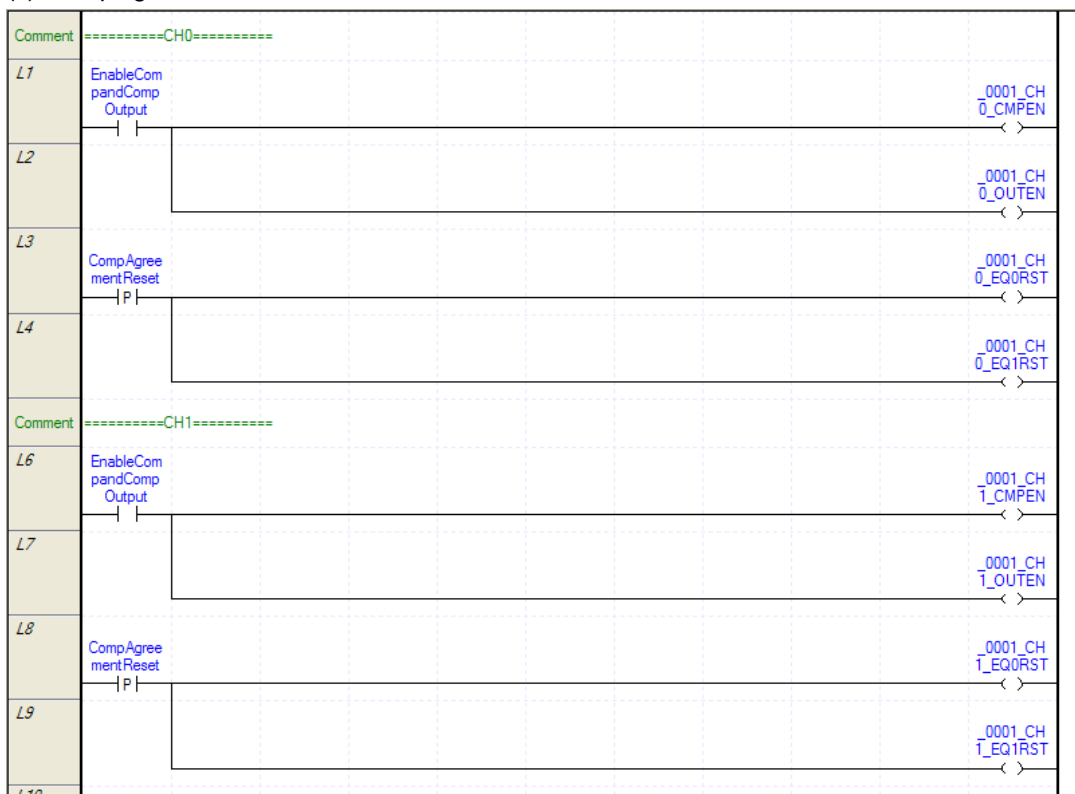

Chapter 7 Program

7.2.13 Comparison output status setting

Program example setting status of comparison output when XGT (XGK/XGI/XGR) CPU module is STOP.

1. Setting content

Parameter	CH0, CH1
Comparison output status when XGT CPU module is STOP	1: Hold comparison output

2. Program

(a) Scan program of XGK series

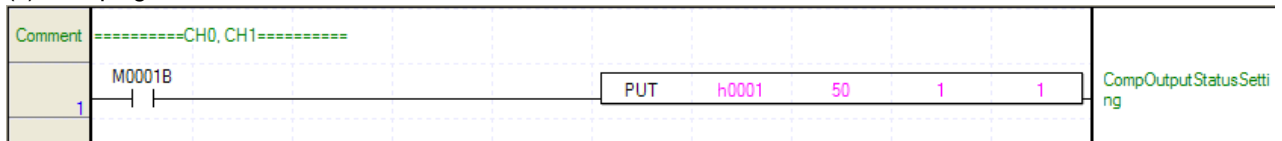

(b) Scan program of XGI/XGR series

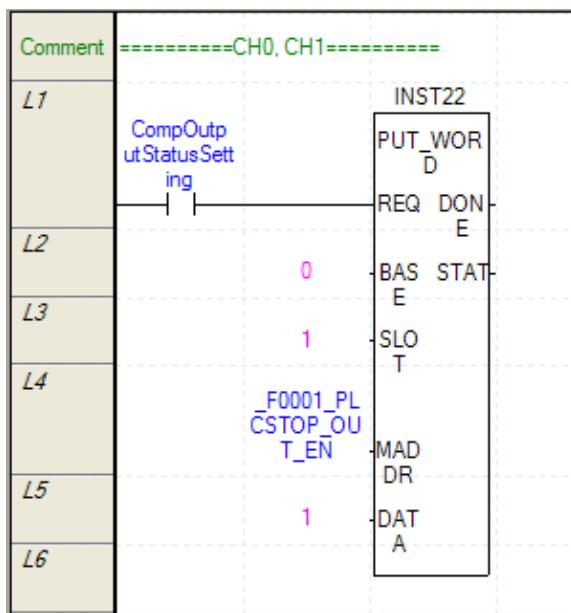

7.2.14 Error status and error code

Program example checking error status and error code occurred at HSC module

1. Program

(a) Scan program of XGK series

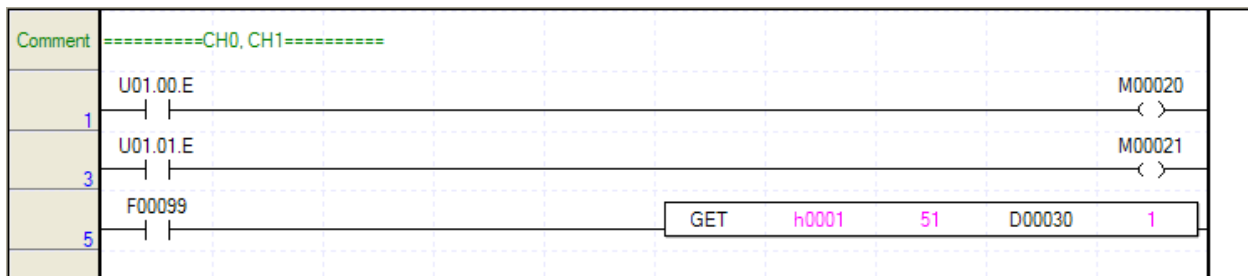

(b) Scan program of XGI/XGR

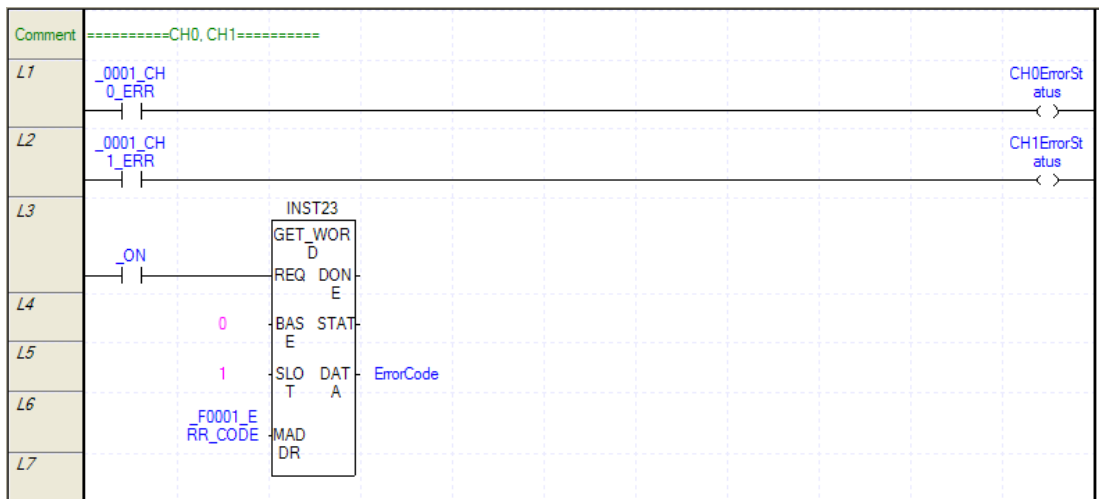

7.2.15 Hold count when power fails

Program example holding current count

To prepare when PLC power is off, current count is saved every scan and if PLC power restart, preset operation is executed with the saved count.

1. Program

(a) Scan program of XGK series

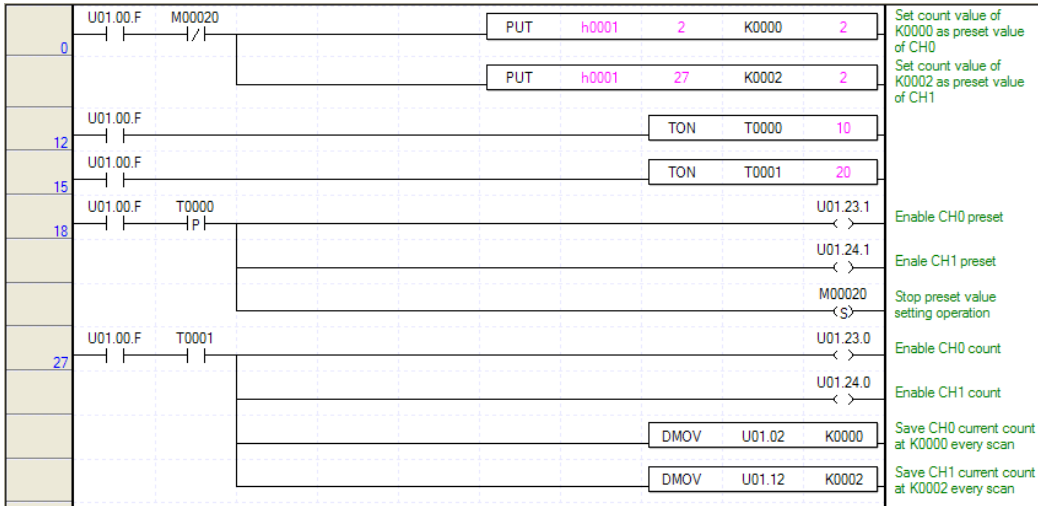

(b) Scan program of XGI/XGR series

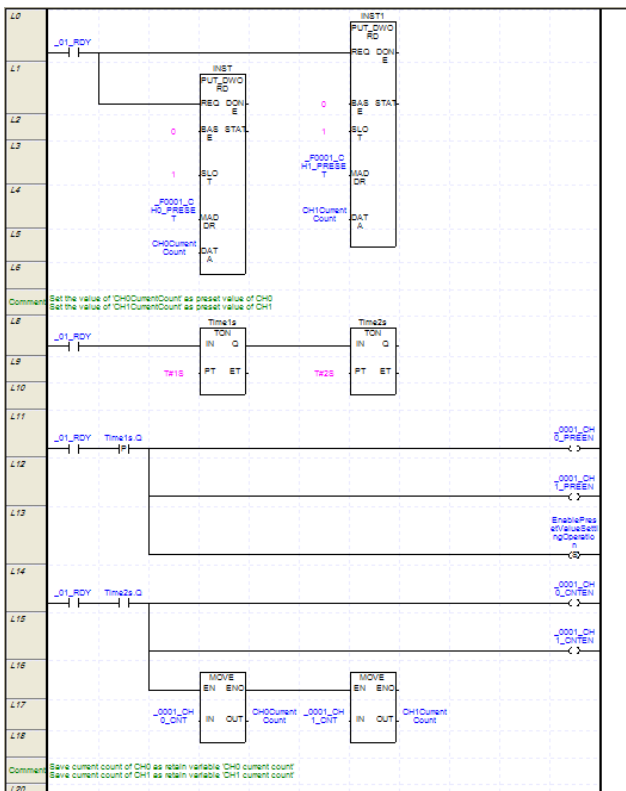

Remark

- (1) In the program, timer (TON) is used for safe operation of Preset value setting and preset allowance
- (2) In scan program of XGI/XGR series, to hold data of 'CH0 current count' and 'CH1 current count' when PLC power is off, the following setting is necessary.
 - (a) On [Basic Parameter], set Restart Method as Warm Restart.

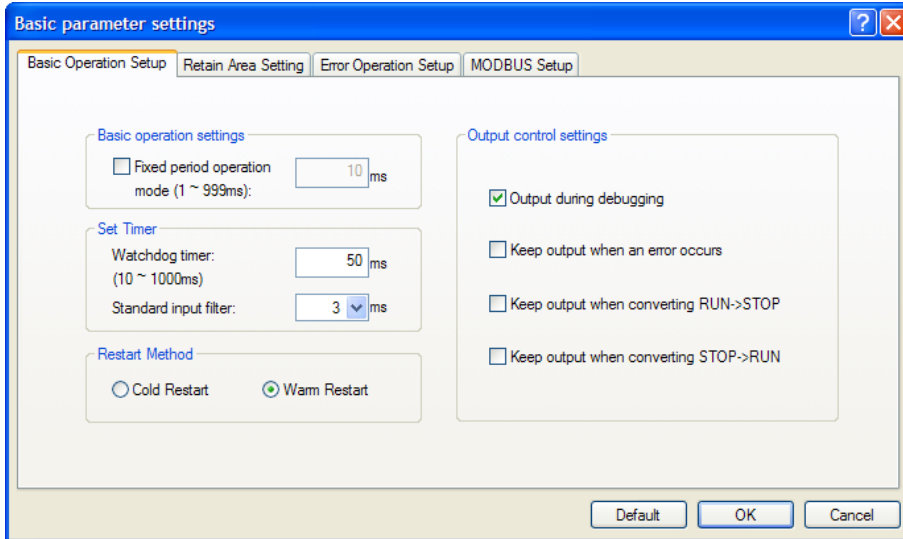

- (b) On scan program, set 'CH0 current count' and 'CH1 current count' as Retain variable.

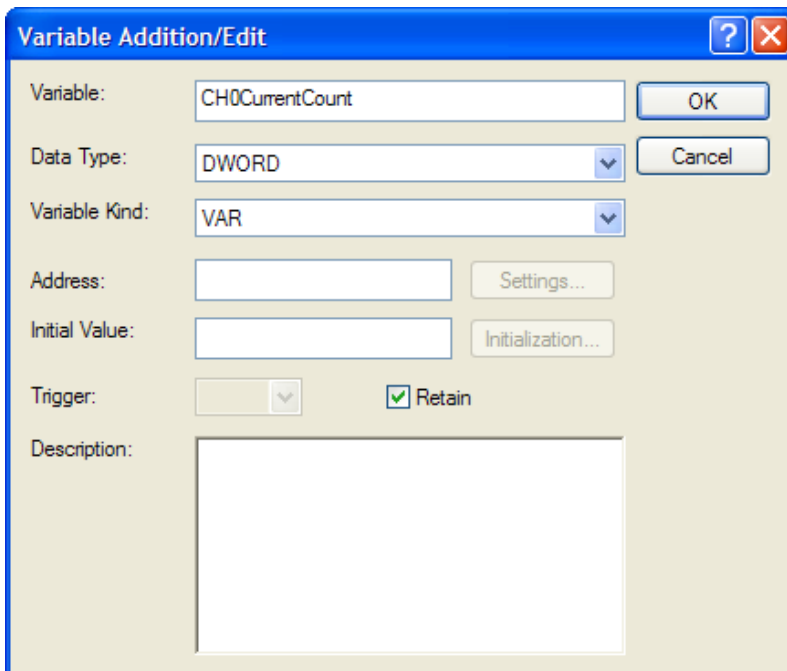

Chapter 8 Troubleshooting

How to shoot the troubles on the high speed counter module will be described.

8.1 Error code

Errors of the high speed counter module are as described below.

Error code (Dec)		Description	RDY LED status
CH0	CH1		
10		Module error (ASIC Reset error)	Blinks every 0.2 sec.
11		Module error (ASIC Memory error)	
12		Module error (ASIC Register error)	
20	120	Counter type range exceeded	Blinks every 1 sec
21	121	Pulse input type range exceeded	
22	122	Auxiliary Mode type range exceeded	
23	123	Sampling Count value range exceeded	
24	124	Compared output0 type range exceeded	
25	125	Compared output1 type range exceeded	
26	126	Preset value exceeded counter range	
27	127	Ring counter minimum. value \geq Ring counter maximum value input	
28	128	Compared output 0 minimum value exceeded maximum input range	
29	129	Compared output 0 maximum value exceeded maximum input range	
30	130	Compared output 0 minimum value > compared output 0 maximum value set	
31	131	Compared output 1 minimum value exceeded maximum input range	
32	132	Compared output 1 maximum value exceeded maximum input range	
33	133	Compared output 1 minimum value > compared output1 maximum value set	
34	134	Pulses per revolution range exceeded	
35	135	Frequency input mode range exceeded	

Notes

- (1) If the module is normal, RDY LED is On.
- (2) If 2 or more errors occur, the module will save the first error code generated, and the displayed error will be first deleted to let the next error deleted.
- (3) In case of serious error which makes RDY LED blinks every 0.2 sec., let power OFF -> ON to delete the error.
- (4) In case of slight error which makes RDY LED blinks every 1 sec., the error can be deleted without power OFF -> ON and the module can keep operating.
- (5) In case of slight error which makes RDY LED blinks every 1 sec, the parameter value causing the applicable error is not set on the module, with the existing parameter value kept as it is.

8.2 Troubleshooting

8.2.1 LED display status of the high speed counter module

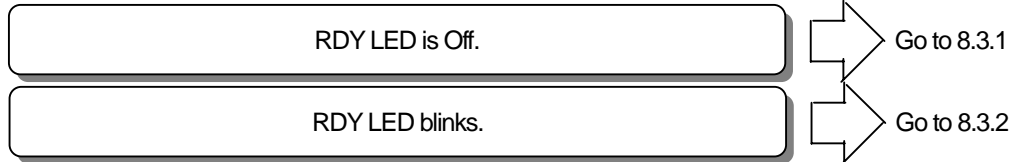

8.2.2 Counter status of the high speed counter module

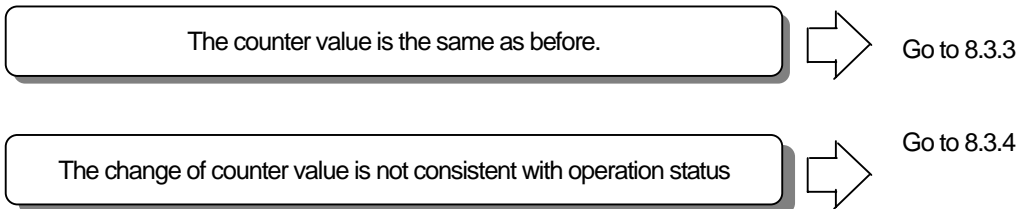

8.2.3 Output status of the high speed counter module

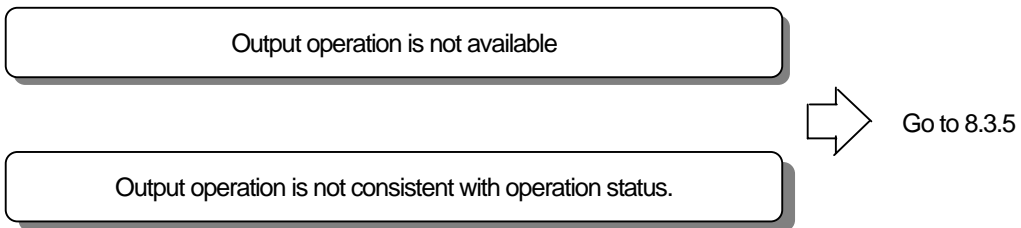

8.3 Troubleshooting sequence

8.3.1 RDY LED Off

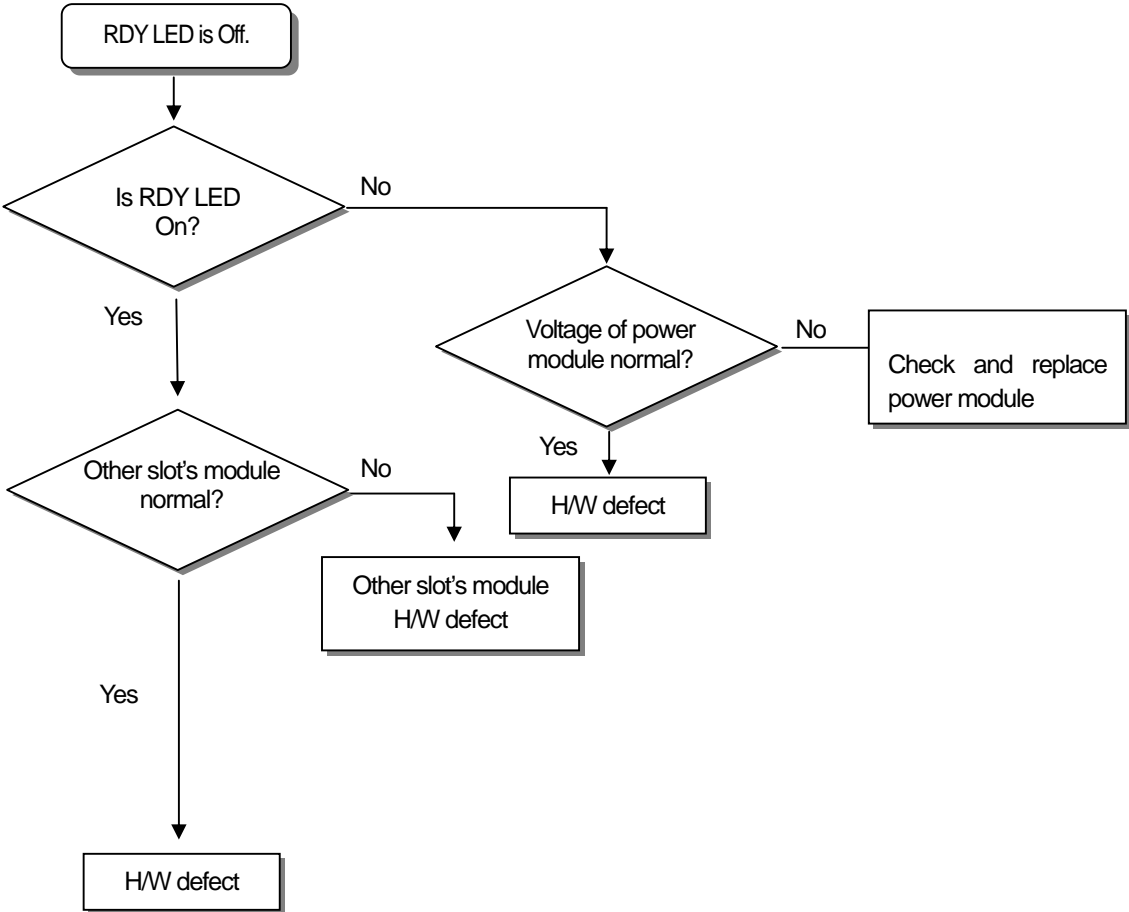

8.3.2 RDY LED Blinks

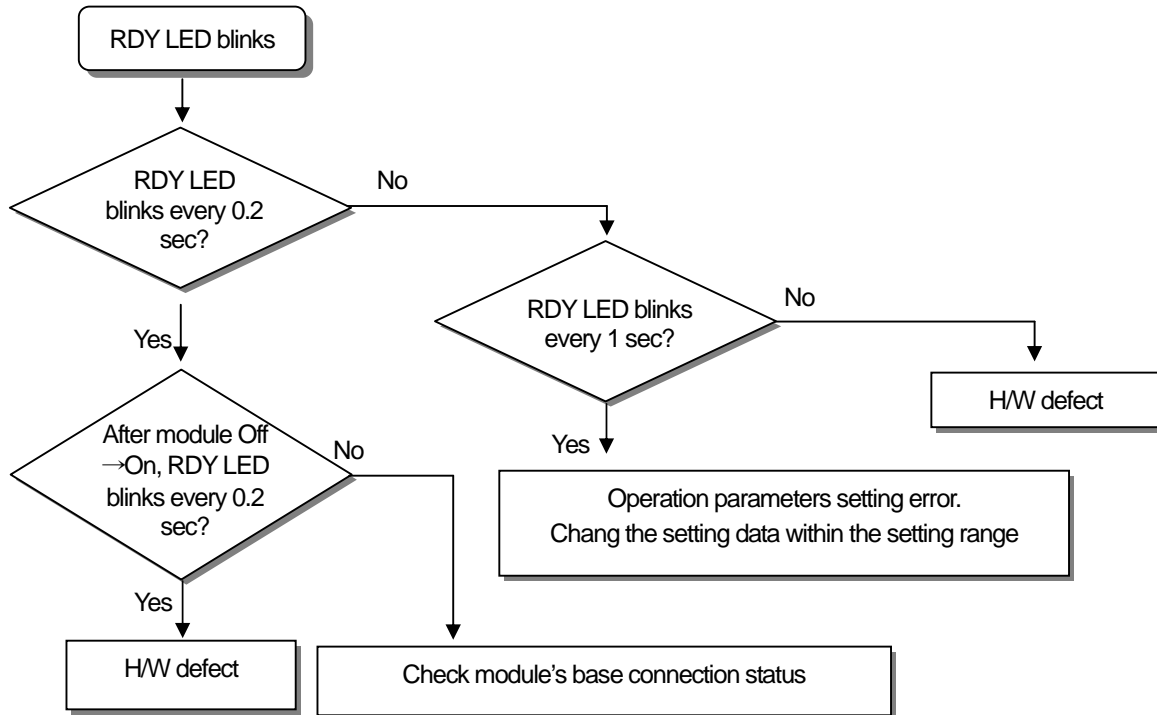

8.3.3 Counter operation error

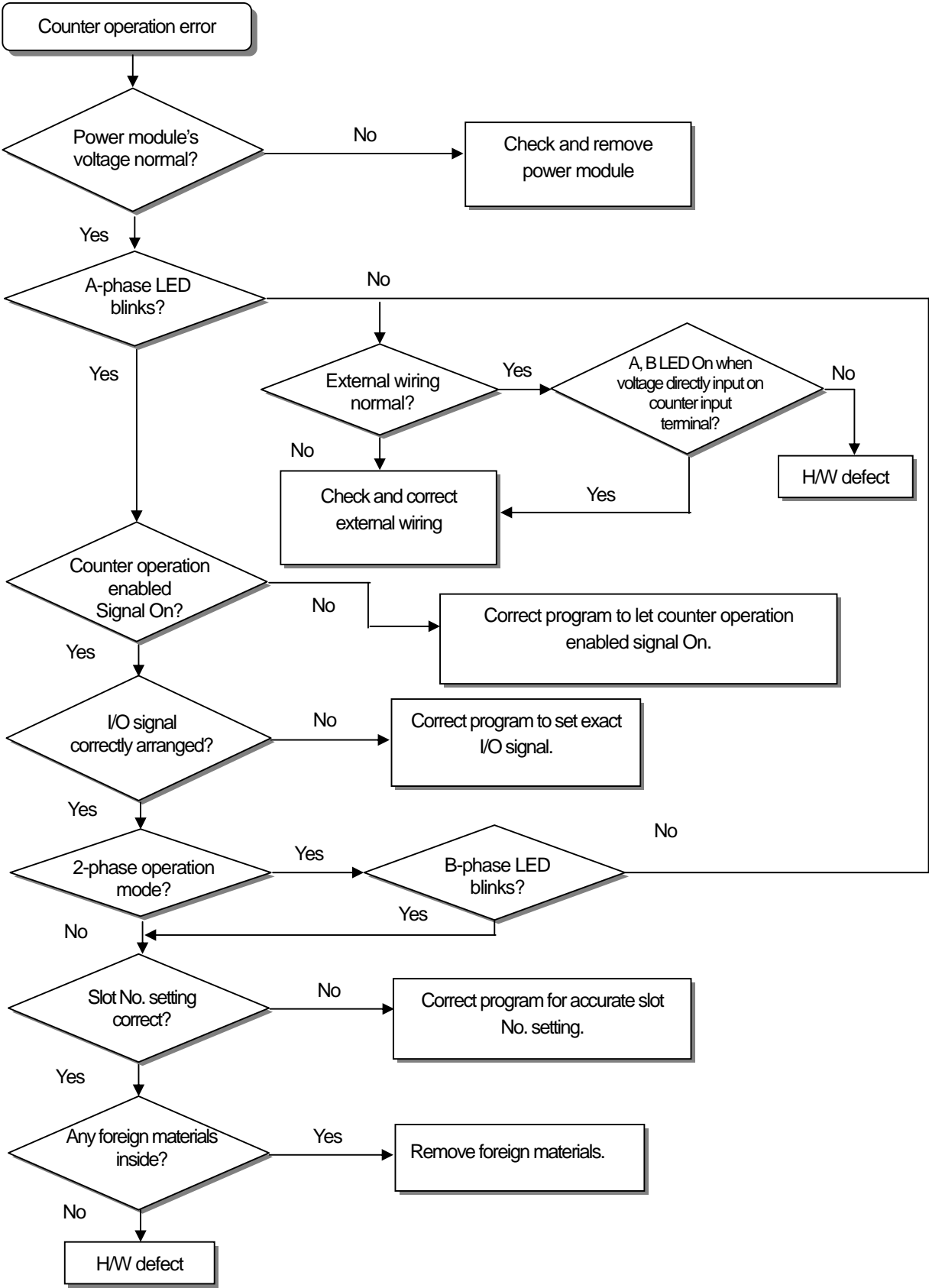

8.3.4 Counter value error

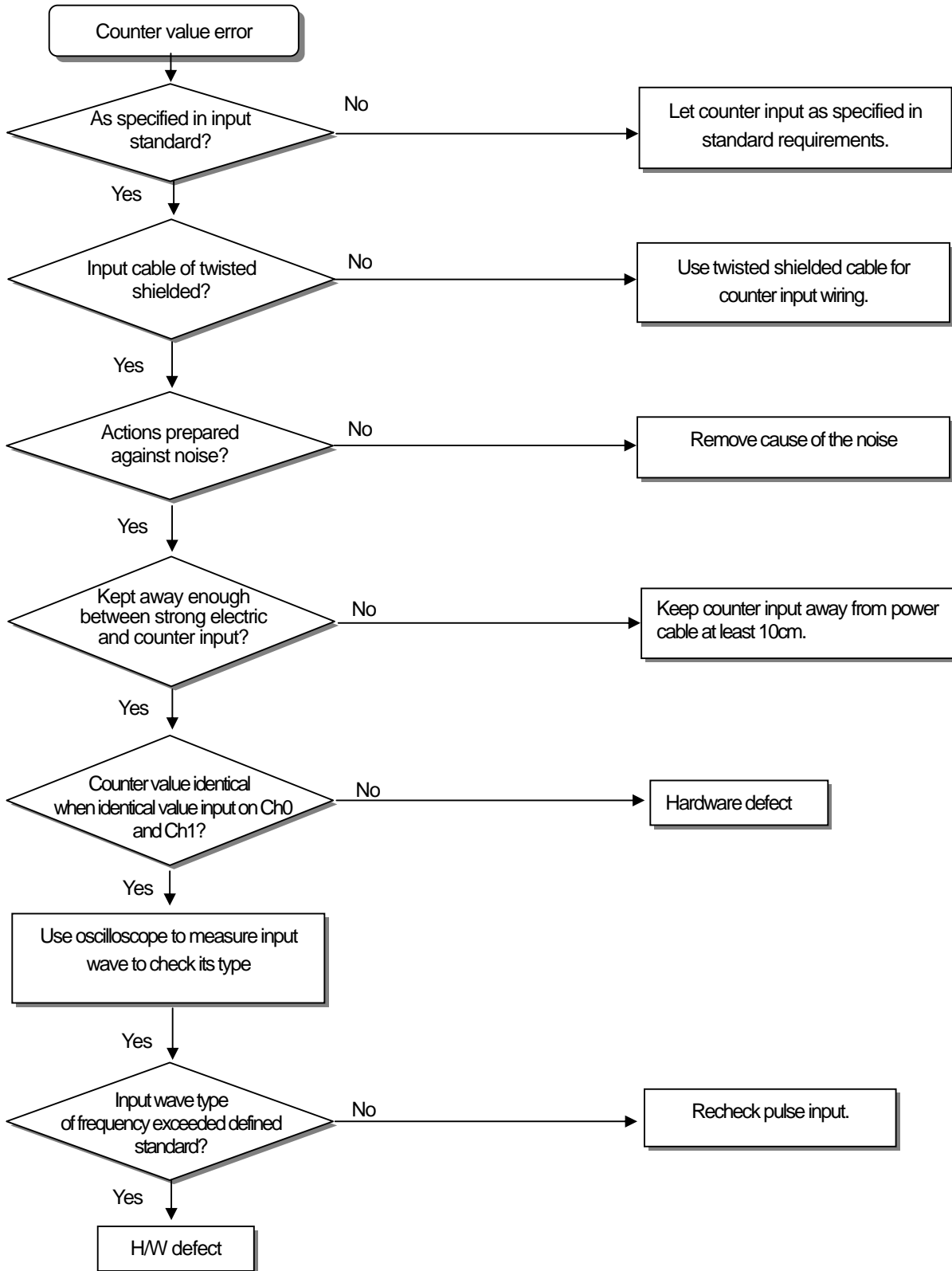

8.3.5 Output operation error

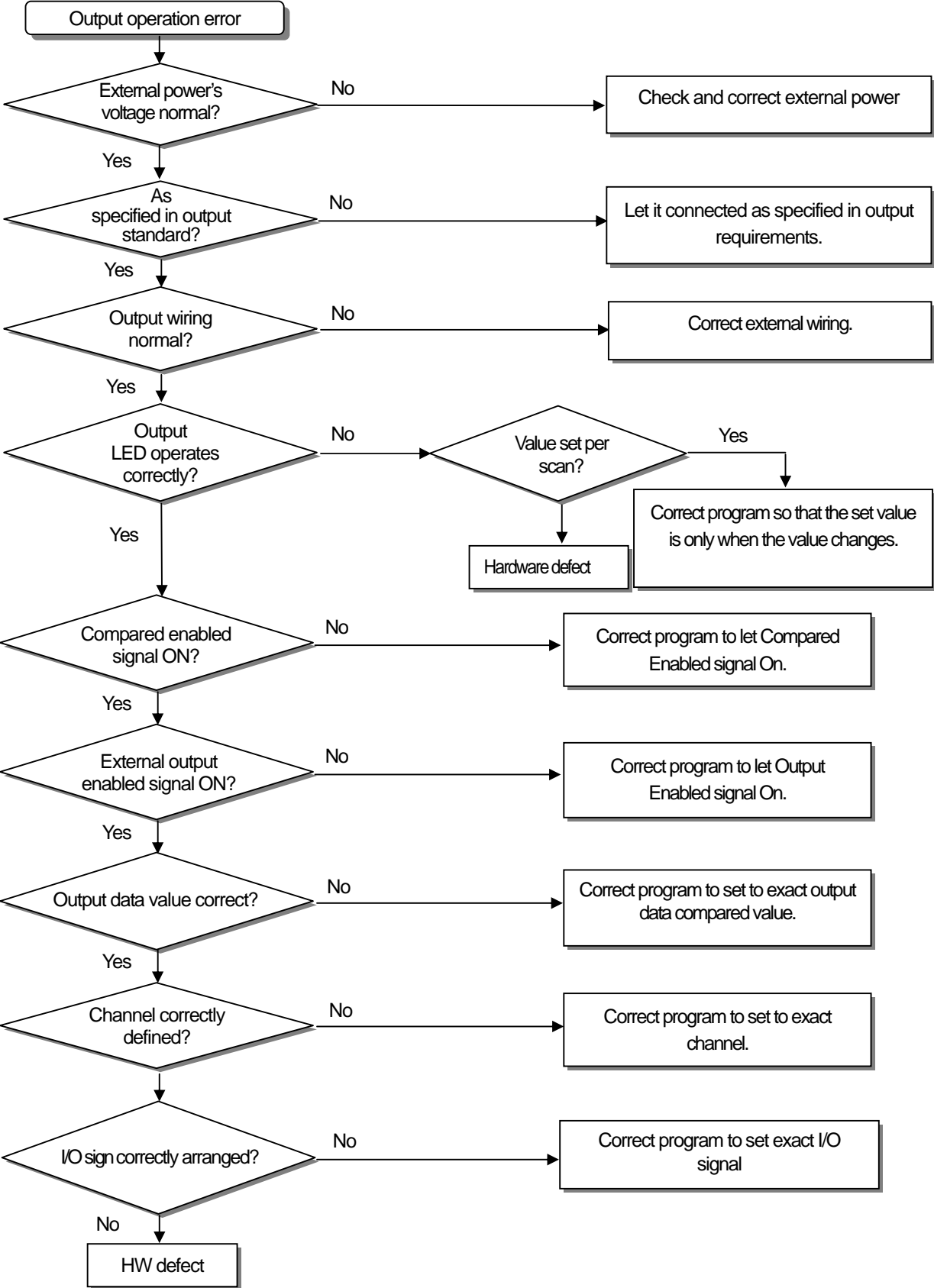

8.3.6 Module status check through XG5000 system monitoring

Module type, module information, OS version and module status of HSC module can be checked through XG5000 system monitoring function.

1) Execution sequence

[Monitor] -> [System Monitoring] -> and on the module screen, click the right mouse button to display [Module Information].

2) Module information

- (1) Module Info: shows the information of the module presently installed.
- (2) OS version: shows the OS version information of the high speed counter module.
- (3) OS date: shows the OS prepared date of the high speed counter module.
- (4) Module status: shows the present error code.

3) System Monitoring

The screenshot displays the 'System Monitoring - NewPLC - [Base 0]' window. The main interface shows a rack of modules with status indicators for XGP-ACF, XGK-CPUS, and XG modules. A 'Special Module Information' dialog box is open, showing the following data:

Item	Information
Module Info	XGF-H02A
OS Version	Module O/S Version 1.10
OS Date	2005(Y) 11(M) 1(D)
Module Status	No Error.

The 'System information' window at the bottom left shows the following tree structure:

- Base 0: XGB-M04A
 - Power: XGP-ACF
 - CPU: XGK-CPUS
 - Slot 0: Empty slot
 - Slot 1: XGQ-TR2A/B
 - Slot 2: XGL-EFMT
 - Slot 3: XGF-H02A

The 'Comment' window at the bottom right shows the following text:

Main Base(4 Slots)
AC100~240V Input
Standard CPU Module(I/O: Maximum 3,072 Points)
Transistor Output, 16 Contacts (0.5A, Sink Output/Source C
Fast Ethernet Module, Electrical Master
High Speed Counter Built-in (1) Input Time(2 Channels)

Appendix 1 Terminology

1. Pulse

Used to turn voltage (current) On/Off for a short time, and pulse line is of continuous pulses

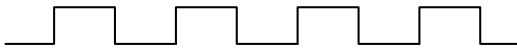

2. Encoder

Used mainly in servo-detector in order to detect speed and position, whose basic principle is that if infrared ray from LED passes the slit disk and reaches the light receiving element, analog electric sign is output which will be converted by voltage comparator to digital sign to be output.

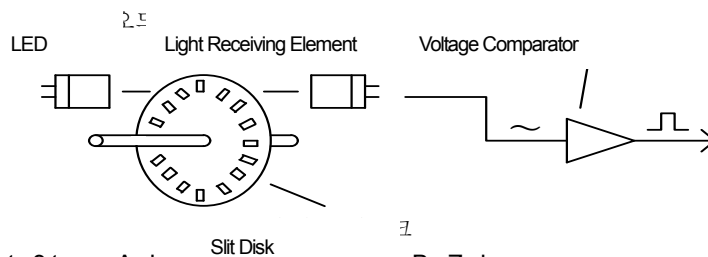

Encoder output is classified into 3 types; A phase

• B • Z phase.

- A phase: Basic output, signal of pulses is output as many as the number of resolutions for 1 revolution of shaft.
- B phase: Signal with a specific phase difference from A phase, which can detect revolution direction of shaft
- Z phase: 1 pulse is output for 1 revolution of shaft.

That is, they are used to reset external counter or to detect the origin position.

3. Manual Pulse Generator

A device that handle can be rotated by hand to generate pulses. If rotated + direction, forward pulses are generated, and if rotated – direction, reverse pulses are generated.

4. Increasing Counter

A counter value increases from -2,147,483,648 to 2,147,483,647 (for 32-bit counter).

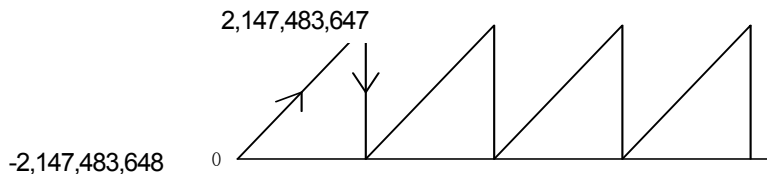

Appendix 1 Terminology

5. Decreasing Counter

A counter value decreases from 2,147,483,647 to -2,147,483,648 (for 32-bit counter).

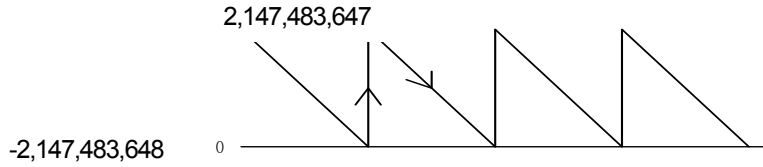

6. Ring Counter

A counter that counter value increases/decreases between the maximum value and the minimum value of the Ring count that user has defined.

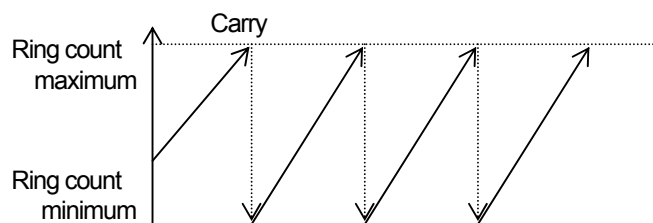

7. 1-Phase Operation Mode

Mode used to count 1-phase input pulse.

8. CW/CCW Operation Mode

Mode used to count another 1-phase if 1 phase is Low among 2-phase input pulses.

9. CW/CCW Operation Mode

Mode used to count 2-phase input pulse.

10. Preset

Mode used to set present counter value to discretionary value.

11. Gate

Signal used to enable additional function operation.

12. Compared Value

Basic value used to compare counters in size.

13. Carry

Signal displayed when Linear count changes from 2,147,483,646 to 2,147,483,647 and when Ring count changes from the maximum value to the minimum value with increasing counter operation.

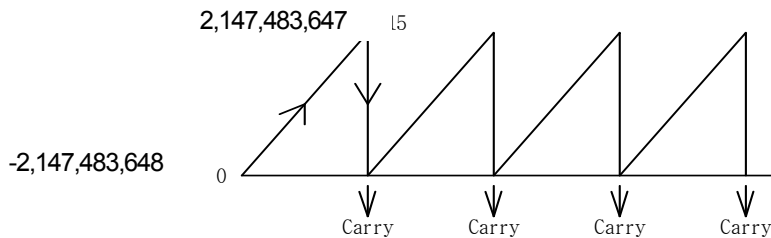

14. Borrow

Signal displayed when Linear count changes from -2,147,483,647 → -2,147,483,648 and when Ring count changes from the minimum value to the maximum value with decreasing counter operation.

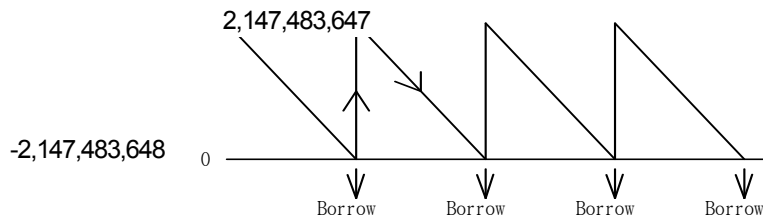

15. LT (<) Signal

Signal displayed if 'present counter value < compared value'.

16. EQ (=) Signal

Signal displayed if 'present counter value = compared value'.

17. GT (>) Signal

Signal displayed if 'present counter value > compared value'.

18. Section Signal (\geq or \leq)

Signal displayed if present counter value is between two user-defined values or exceeds the two values.

19. External Preset

External signal used to change present counter value to discretionarily specified value.

20. External Gate

External signal used to enable the additional function operation.

Appendix 2 Dimensions

1. Dimensions

1) XGF-HO2A / XGF-HD2A

Unit: mm

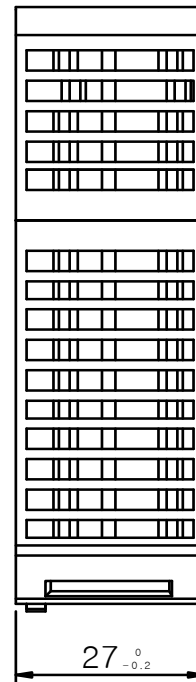
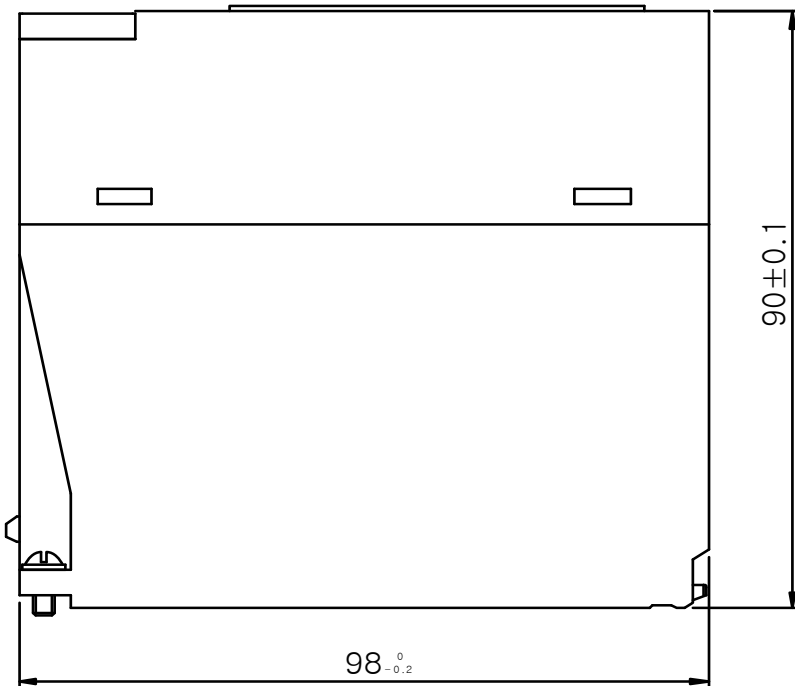
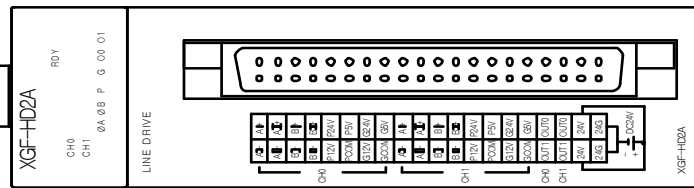

Appendix 3 GM Function Block Conversion Program

1. Preset value setting Function Block

(1) Preset value setting Function Block of GN (HSCC-PRE)

- Preset value setting Function Block sets count start value of HSC module. To change Count, execute Enable Preset after Preset value setting Function Block acts.

Function Block type	Classification	Variable name	Type	Contents		
	Input	REQ	BOOL	FB execution	Executed when changing "0->1" (\uparrow : Rising edge)	
		BASE	USINT	Base Number	Base number where HSC module is equipped	
		SLOT	USINT	Slot Number	Slot number where HSC module is equipped	
		CH	BOOL	Channel	Ch0	0
					Ch1	1
	PSET_VAL	DINT	Preset range	-2,147,483,648 ~ 2,147,483,647		
	Output	DONE	BOOL	Execution status	If it completes, it outputs 1 and holds. If error occurs, it outputs 0	
		STAT	USINT	Error status	In case of error, outputs error code	

(2) Preset value setting FB of XGI/XGR

Function Block type	Classification	Variable name	Type	Contents		
	Input	REQ	BOOL	FB execution	Executed when changing "0->1" (\uparrow : Rising edge)	
		BASE	USINT	Base Number	Base number where HSC module is equipped	
		SLOT	USINT	Slot Number	Slot number where HSC module is equipped	
		MADDR	USINT	Channel	Ch0	<u>_F01_CH0_PRESET</u> 02
					Ch1	<u>_F01_CH1PRESET</u> 27
	PSET_VAL	DWORD	Preset range	-2,147,483,648 ~ 2,147,483,647		
	Output	DONE	BOOL	Execution status	If it completes, it outputs 1 and holds. If error occurs, it outputs 0	
STAT		USINT	Error status	In case of error, outputs error code		

Remark

- (1) Input variable 'MADDR' of XGI/XGR FB indicates internal memory. Constant or Global variable is inputted. If we refer to above example, "_F01_CH0_PRESET" is Global constant indicating "02". Namely, if you input "02" at "MADDR", result of XGI/XGR FB is same.
- (2) If you use "PUT_DINT" instead of "PUT_DWORD", preset action is same. At this time, data type of input variable "DATA" becomes DINT.
- (3) Not Preset value setting FB (HSCC_PRE) but also Mode setting function (HSCC_NOD), Auxiliary function setting function (HSCC_AUX), Comparison setting function (HSCC_CMP), Count read function (HSCC_CNT), Operation information setting function (HSCC_WR), Operation status read function (HSCC_RD), Comparison output setting function (HSCC_OUT) apply to (1), (2).
- (4) When writing conversion program, if input enters REQ and next input is connected with DONE, execution status of previous instruction should complete to be used as input of next instruction. If it is error status, it doesn't operate.
- (5) In case of XGR CPU, HSC module should be equipped at extension base.

Appendix 3 GM Function Block Conversion Program

2. Mode setting function block

(1) Mode setting function block of GM (HSCC_MOD)

- Mode setting function block sets pulse input type and count type of HSC module.

Function Block type	Classification	Variable name	Type	Contents		
	Input	REQ	BOOL	FB execution	Executed when changing "0->1" (: Rising edge)	
		BASE	USINT	Base Number	Base number where HSC module is equipped	
		SLOT	USINT	Slot Number	Slot number where HSC module is equipped	
		CH	BOOL	Channel	Ch0	0
					Ch1	1
		CNT_MODE	BOOL	Count type	0	Linear count
					1	Ring count
		IN_MODE	USINT	Pulse input type	0	2 phase 1 multiplication
					1	2 phase 2 multiplication
					2	2 phase 4 multiplication
					3	CW/CCW
					4	1phase 1input 1multiplication(Program up/down input)
	5				1phase 1input 2multiplication (Program up/down input)	
	6				1phase 2input 1multiplication (B phase up/down input)	
7	1phase 2input 2multiplication(B phase up/down input)					
RING_MIN	DINT	Ring upper limit	-2,147,483,648 ~ 2,147,483,647			
RING_MAX	DINT	Ring lower limit	-2,147,483,648 ~ 2,147,483,647			
Output	DONE	BOOL	Execution status	If it completes, it outputs 1 and holds. If error occurs, it outputs 0		
	STAT	USINT	Error status	In case of error, outputs error code		

(2) Mode setting function block of XGI/XGR

- Since XGI/XGR can't process Mode setting Function Block (HSCC_MOD) at once like GM, it combines methods such as count type, pulse input type, Ring upper/lower count to execute function block.

(a) Count type setting

Function block type	Classification	Variable name	Type	Contents		
	Input	REQ	BOOL	FB execution	Executed when changing "0->1" (: Rising edge)	
		BASE	USINT	Base Number	Base number where HSC module is equipped	
		SLOT	USINT	Slot Number	Slot number where HSC module is equipped	
		MADDR	UINT	CH	Ch0	_Fxy_CH0_CNT_MODE 00
					Ch1	_Fxy_CH1_CNT_MODE 25
		DATA	DWORD	Count type setting	0	Linear count
	1				Ring count	
	Output	DONE	BOOL	Execution status	If it completes, it outputs 1 and holds. If error occurs, it outputs 0	
		STAT	USINT	Error status	In case of error, outputs error code	

Appendix 3 GM Function Block Conversion Program

(b) Pulse input type setting

Function Block Type	Classification	Variable name	Type	Contents			
	Input	REQ	BOOL	FB execution	Executed when changing "0->1" (\uparrow : Rising edge)		
		BASE	USINT	Base Number	Base number where HSC module is equipped		
		SLOT	USINT	Slot Number	Slot number where HSC module is equipped		
		MADDR	UINT	Channel	Ch0	_Fxy_CH0_PLS_MODE	01
					Ch1	_Fxy_CH1_PLS_MODE	26
		DATA	DWORD	Pulse input mode setting	0	2phase 1multiplication	
					1	2phase 2multiplication	
					2	2phase 4multiplication	
					3	CW/CCW	
					4	1phase 1input 1multiplication(Program up/down input)	
	5				1phase 1input 2multiplication(Program up/down input)		
	6				1phase 2input 1multiplication(B phase up/down input)		
7	1phase 2input 2multiplication (B phase up/down input)						
Output	DONE	BOOL	Execution status	If it completes, it outputs 1 and holds. If error occurs, it outputs 0			
	STAT	USINT	Error status	In case of error, outputs error code			

(c) Ring count lower limit setting

Function Block type	Classification	Variable name	Type	Contents			
	Input	REQ	BOOL	FB execution	Executed when changing "0->1" (\uparrow : Rising edge)		
		BASE	USINT	Base Number	Base number where HSC module is equipped		
		SLOT	USINT	Slot Number	Slot number where HSC module is equipped		
		MADDR	UINT	Channel	Ch0	_Fxy_CH0_RING_MIN	04
					Ch1	_Fxy_CH1_RING_MIN	29
	DATA	DWORD	Ring Count lower limit	-2,147,483,648 ~ 2,147,483,647			
	Output	DONE	BOOL	Execution status	If it completes, it outputs 1 and holds. If error occurs, it outputs 0		
		STAT	USINT	Error status	In case of error, outputs error code		

Appendix 3 GM Function Block Conversion Program

(d) Ring count upper limit setting

Function Block type	Classification	Variable name	Type	Contents			
	Input	REQ	BOOL	FB execution Executed when changing "0->1" (\uparrow : Rising edge)			
		BASE	USINT	Base Number Base number where HSC module is equipped			
		SLOT	USINT	Slot Number Slot number where HSC module is equipped			
		MADDR	UINT	Channel	Ch0	_Fxy_CH0_RING_MAX	06
				Ch1	_Fxy_CH0_RING_MAX	31	
	DATA	DWORD	Ring count upper limit	-2,147,483,648 ~ 2,147,483,647			
	Output	DONE	BOOL	Execution status If it completes, it outputs 1 and holds. If error occurs, it outputs 0			
		STAT	USINT	Error status In case of error, outputs error code			

(f) Conversion program

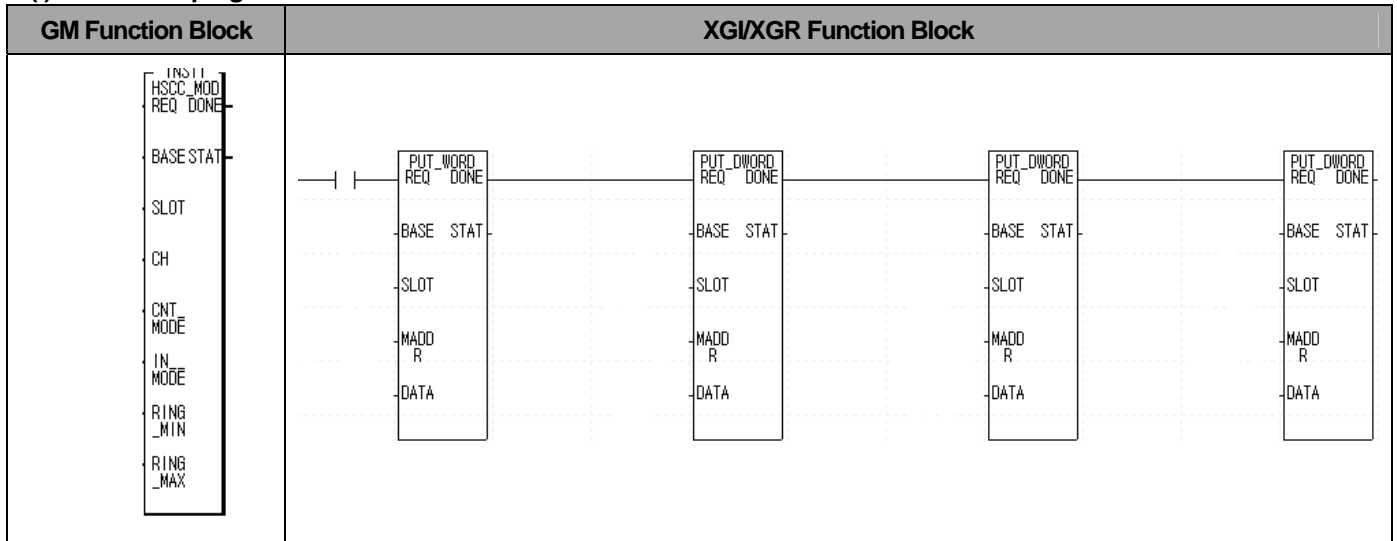

3. Auxiliary function setting function block

(1) GM auxiliary function setting function block (HSCC_AUX)

- Auxiliary function setting function block sets auxiliary function of HSC module. To execute auxiliary function, execute Enable auxiliary function after auxiliary function block acts.

Function Block type	Classification	Variable name	Type	Contents		
<div style="border: 1px solid black; padding: 5px; width: fit-content;"> INSI2 HSCC_AUX REQ DONE BASE STAT SLOT CH AUX SET_TIME SET_PULS FREQ UNIT </div>	Input	REQ	BOOL	FB execution	Executed when changing "0->1" (: Rising edge)	
		BASE	USINT	Base Number	Base number where HSC module is equipped	
		SLOT	USINT	Slot Number	Slot number where HSC module is equipped	
		CH	BOOL	Channel	Ch0	0
					Ch1	1
		AUX	USINT	Auxiliary function type setting	0	Not use
					1	Count Clear
					2	Count Latch
					3	Sampling frequency
					4	Measure input Freq.
					5	Revolution/unit time
					6	Disable count
		SET_TIME	UINT	Sampling count setting value	Revolution/unit time	1 ~ 65,535(ms)
					Revolution/unit time	1 ~ 65,535(ms)
	SET_PULS	UINT	No. of pulse /unit revolution	1 ~ 65,535(pulse)		
	FREQ UNIT	UINT	Input frequency setting	0	0 Hz	
1				10 Hz		
2				100 Hz		
3				1000 Hz		
Output	DONE	BOOL	Execution status	If it completes, it outputs 1 and holds. If error occurs, it outputs 0		
	STAT	USINT	Error status	In case of error, outputs error code		

Appendix 3 GM Function Block Conversion Program

(2) XGI/XGR auxiliary function setting function block

(a) Auxiliary function type setting

Function Block type	Classification	Variable name	Type	Contents				
	Input	REQ	BOOL	FB execution	Executed when changing "0->1" (: Rising edge)			
		BASE	USINT	Base Number	Base number where HSC module is equipped			
		SLOT	USINT	Slot Number	Slot number where HSC module is equipped			
		MADDR	UINT	CH	Ch0	<u>Fxy_CH0_AUX_MODE</u> 18		
					Ch1	<u>Fxy_CH1_AUX_MODE</u> 43		
				DATA	DWORD	Auxiliary function type setting	0	Not use
							1	Count clear
							2	Latch count
							3	Sampling count
							4	Measure input Freq.
		5	Revolution/unit time					
		6	Disable count					
	Output	DONE	BOOL	Execution status	If it completes, it outputs 1 and holds. If error occurs, it outputs 0			
		STAT	USINT	Error status	In case of error, outputs error code			

(b) Sampling count setting

Function Block type	Classification	Variable name	Data type	Contents				
	Input	REQ	BOOL	FB execution	Executed when changing "0->1" (: Rising edge)			
		BASE	USINT	Base Number	Base number where HSC module is equipped			
		SLOT	USINT	Slot Number	Slot number where HSC module is equipped			
		MADDR	UINT	CH	Ch0	<u>Fxy_CH0_PERIOD</u> 19		
					Ch1	<u>Fxy_CH1_PERIOD</u> 44		
				DATA	DWORD	Sampling setting value	1~65,535(ms)	
						Output	Execution status	If it completes, it outputs 1 and holds. If error occurs, it outputs 0
							Error status	In case of error, outputs error code
			Output	DONE	BOOL	Execution status	If it completes, it outputs 1 and holds. If error occurs, it outputs 0	
				STAT	USINT	Error status	In case of error, outputs error code	

Appendix 3 GM Function Block Conversion Program

(c) Sampling count setting conversion program

GM Function Block	XGI/XGR Function Block			
<div style="border: 1px solid black; padding: 5px; width: fit-content; margin: 0 auto;"> INST2 HSCC_AUX REQ_DONE </div>				
0 BASE STAT	0 BASE STAT	0 BASE STAT	0 BASE STAT	
1 SLOT	1 SLOT	1 SLOT	1 SLOT	
0 CH	0 CH	0 CH	0 CH	
3 AUX	3 AUX	3 AUX	3 AUX	
500 SET TIME	_F01_CH0_A UX_MODE MADDR	_F01_CH0_P ERTOD MADDR	500 DATA	
0 SET PULS	0 SET PULS	0 SET PULS	0 SET PULS	
0 FREQ UNIT	3 DATA	500 DATA	0 FREQ UNIT	

(d) Input frequency setting

Function Block type	Classification	Variable name	Type	Contents			
<div style="border: 1px solid black; padding: 5px; width: fit-content; margin: 0 auto;"> INST27 PUT_WORD REQ_DONE BASE_STAT SLOT MADDR DATA </div>	Input	REQ	BOOL	FB execution Executed when changing "0->1" (\uparrow : Rising edge)			
		BASE	USINT	Base Number Base number where HSC module is equipped			
		SLOT	USINT	Slot Number Slot number where HSC module is equipped			
		MADDR	UINT	CH	Ch0	_Fxy_CH0_FREQ_MODE	21
					Ch1	_Fxy_CH0_FREQ_MODE	46
		DATA	DWORD	Input Freq. setting	0	0 Hz	
	1				10 Hz		
	2				100 Hz		
	3				1000 Hz		
	Output	DONE	BOOL	Execution status If it completes, it outputs 1 and holds. If error occurs, it outputs 0			
STAT		USINT	Error status In case of error, outputs error code				

(e) Input frequency conversion program

GM Function Block	XGI/XGR Function Block			
<div style="border: 1px solid black; padding: 5px; width: fit-content; margin: 0 auto;"> INST2 HSCC_AUX REQ_DONE </div>				
0 BASE STAT	0 BASE STAT	0 BASE STAT	0 BASE STAT	
1 SLOT	1 SLOT	1 SLOT	1 SLOT	
0 CH	0 CH	0 CH	0 CH	
4 AUX	4 AUX	4 AUX	4 AUX	
0 SET TIME	_F01_CH0_A UX_MODE MADDR	_F01_CH0_F REQ_MODE MADDR	0 SET TIME	
0 SET PULS	0 SET PULS	0 SET PULS	0 SET PULS	
1 FREQ UNIT	4 DATA	1 DATA	1 FREQ UNIT	

Appendix 3 GM Function Block Conversion Program

(f) Measure revolution/ unit time

Function Block type	Classification	Variable name	Type	Contents			
	Input	REQ	BOOL	FB execution	Executed when changing "0->1" (\uparrow : Rising edge)		
		BASE	USINT	Base Number	Base number where HSC module is equipped		
		SLOT	USINT	Slot Number	Slot number where HSC module is equipped		
		MADDR	UINT	CH	Ch0	_Fxy_CH0_REV_UNIT	20
				Ch1	_Fxy_CH0_REV_UNIT	45	
	DATA	DWORD	Revolution/unit time	1~65,535(ms)			
	Output	DONE	BOOL	Execution status	If it completes, it outputs 1 and holds. If error occurs, it outputs 0		
		STAT	USINT	Error status	In case of error, outputs error code		

(g) Revolution/unit time conversion program

GM Function Block	XGI/XGR Function Block					

Appendix 3 GM Function Block Conversion Program

(h) Disable count

Function Block Type	Classification	Variable name	Type	Contents			
	Input	REQ	BOOL	FB execution	Executed when changing "0->1" (⬆ : Rising edge)		
		BASE	USINT	Base Number	Base number where HSC module is equipped		
		SLOT	USINT	Slot Number	Slot number where HSC module is equipped		
		MADDR	UINT	CH	Ch0	_Fxy_CH0_AUX_MODE	18
					Ch1	_Fxy_CH1_AUX_MODE	43
					0	Not use	
					1	Count clear	
					2	Latch count	
					3	Sampling count	
					4	Measure input freq.	
			5	Revolution/Unit time			
			6	Disable count			
	Output	DONE	BOOL	Execution status	If it completes, it outputs 1 and holds. If error occurs, it outputs 0		
		STAT	USINT	Error status	In case of error, outputs error code		

(i) Disable count conversion program

GM Function Block	XGI/XGR Function Block

Appendix 3 GM Function Block Conversion Program

4. Comparison function setting function block

(1) GM comparison function setting function block (HSCC_CMP)

- Comparison function setting function sets reference value to compare

Function Block type	Classification	Variable name	Type	Contents			
	Input	REQ	BOOL	FB execution	Executed when changing "0->1" (\uparrow : Rising edge)		
		BASE	USINT	Base Number	Base number where HSC module is equipped		
		SLOT	USINT	Slot Number	Slot number where HSC module is equipped		
		CH	BOOL	CH	Ch0	0	
					Ch1	1	
		CMP0_SEL/ MP1_SEL	USINT	Comp Output type	0	<	Single Comp: small
					1	≤	Single Comp: small or same
					2	=	Single: same
					3	≥	Single Comp: large or same
					4	>	Single Comp: large
	5				≤≤	Sampling Comp: include	
	6	≥≤	Sampling Comp: exclusive				
	CMP0_MIN/ MP1_MIN	DINT	Single or sampling Comp Min. setting	-2,147,483,648 ~ 2,147,483,647			
	CMP0_MAX/ CMP1_MAX	DINT	Sampling Comp Max. setting	-2,147,483,648 ~ 2,147,483,647			
Output	DONE	BOOL	Execution status	If it completes, it outputs 1 and holds. If error occurs, it outputs 0			
	STAT	USINT	Error status	In case of error, outputs error code			

(1) XGI/XGR Comp function setting function block

(a) Comp Output 0

Function Block type	Classification	Variable name	Type	Contents			
	Input	REQ	BOOL	FB execution	Executed when changing "0->1" (\uparrow : Rising edge)		
		BASE	USINT	Base Number	Base number where HSC module is equipped		
		SLOT	USINT	Slot Number	Slot number where HSC module is equipped		
		MADDR	UINT	CH	Ch0	$_Fxy_CH0_CP0_MODE$ 08	
					Ch1	$_Fxy_CH1_CP0_MODE$ 33	
		DATA	DWORD	Comp output setting	0	<	Single Comp: small
					1	≤	Single Comp: small or same
					2	=	Single Comp: same
					3	≥	Single Comp: larger or same
					4	>	Single Comp: large
	5				≤≤	Sampling Comp: include	
	6	≥≤	Sampling Comp: exclude				
	Output	DONE	BOOL	Execution status	If it completes, it outputs 1 and holds. If error occurs, it outputs 0		
		STAT	USINT	Error status	In case of error, outputs error code		

Appendix 3 GM Function Block Conversion Program

(b) Comp reference value (Single Comp) Comp Min. value of Comp output 0

Function Block type	classification	Variable name	Data type	Contents		
<div style="border: 1px solid black; padding: 5px; width: fit-content;"> INST41 PUT_WORD REQ DONE <hr/> BASE STAT <hr/> SLOT <hr/> MADDR <hr/> DATA </div>	Input	REQ	BOOL	FB execution	Executed when changing "0->1" (\uparrow : Rising edge)	
		BASE	USINT	Base Number	Base number where HSC module is equipped	
		SLOT	USINT	Slot Number	Slot number where HSC module is equipped	
		MADDR	UINT	CH	Ch0	<u>_Fxy_CH0_CP0_MIN</u> 10
					Ch1	<u>_Fxy_CH1_CP0_MIN</u> 35
	DATA	DWORD	Single or sampling Comp Min. setting value -2,147,483,648 ~ 2,147,483,647			
	Output	DONE	BOOL	Execution status	If it completes, it outputs 1 and holds. If error occurs, it outputs 0	
		STAT	USINT	Error status	In case of error, outputs error code	

(c) Max. value of Comp Output 0 (Sampling Comp)

Function Block type	Classification	Variable name	Data type	Contents		
<div style="border: 1px solid black; padding: 5px; width: fit-content;"> INST42 PUT_WORD REQ DONE <hr/> BASE STAT <hr/> SLOT <hr/> MADDR <hr/> DATA </div>	Input	REQ	BOOL	FB execution	Executed when changing "0->1" (\uparrow : Rising edge)	
		BASE	USINT	Base Number	Base number where HSC module is equipped	
		SLOT	USINT	Slot Number	Slot number where HSC module is equipped	
		MADDR	UINT	CH	Ch0	<u>_Fxy_CH0_CP0_MAX</u> 12
					Ch1	<u>_Fxy_CH1_CP0_MAX</u> 37
	DATA	DWORD	Sampling Comp Max. setting value -2,147,483,648 ~ 2,147,483,647			
	Output	DONE	BOOL	Execution status	If it completes, it outputs 1 and holds. If error occurs, it outputs 0	
		STAT	USINT	Error status	In case of error, outputs error code	

Appendix 3 GM Function Block Conversion Program

(e) Comp Output 1

Function Block type	Classification	Variable name	Data type	Contents		
	Input	REQ	BOOL	FB execution	Executed when changing "0->1" (\uparrow : Rising edge)	
		BASE	USINT	Base Number	Base number where HSC module is equipped	
		SLOT	USINT	Slot Number	Slot number where HSC module is equipped	
		MADDR	UINT	CH	Ch0	<code>_Fxy_CH0_CP1_MODE</code> 09
					Ch1	<code>_Fxy_CH1_CP1_MODE</code> 34
		DATA	DWORD	Comp Output Type	0	< Single Comp: small
					1	≤ Single Comp: small or same
	2				= Single Comp: same	
	3				≥ Single Comp: large or same	
	4				> Single Comp: large	
5	≤≤ Sampling Comp: Include					
Output	DONE	BOOL	Execution status	If it completes, it outputs 1 and holds. If error occurs, it outputs 0		
	STAT	USINT	Error status	In case of error, outputs error code		

(e) Comp reference value (Single Comp) / Min. value (Sampling Comp) of Comp output 1

Function Block type	Classification	Variable name	Type	Contents		
	Input	REQ	BOOL	FB execution	Executed when changing "0->1" (\uparrow : Rising edge)	
		BASE	USINT	Base Number	Base number where HSC module is equipped	
		SLOT	USINT	Slot Number	Slot number where HSC module is equipped	
		MADDR	UINT	CH	Ch0	<code>_Fxy_CH0_CP0_MIN</code> 10
					Ch1	<code>_Fxy_CH1_CP0_MIN</code> 35
	DATA	DWORD	Single or Sampling Comp Min. setting value -2,147,483,648 ~ 2,147,483,647			
	Output	DONE	BOOL	Execution status	If it completes, it outputs 1 and holds. If error occurs, it outputs 0	
STAT		USINT	Error status	In case of error, outputs error code		

Appendix 3 GM Function Block Conversion Program

(f) Comp Max. value of Comp Output 1 (Sampling Comp)

Function Block type	Classification	Variable name	Type	Content			
<div style="border: 1px solid black; padding: 5px; width: fit-content;"> INST142 PUT_WORD REQ DONE BASE STAT SLOT MADDR DATA </div>	Input	REQ	BOOL	FB execution	Executed when changing "0->1" (\uparrow : Rising edge)		
		BASE	USINT	Base Number	Base number where HSC module is equipped		
		SLOT	USINT	Slot Number	Slot number where HSC module is equipped		
		MADDR	UINT	CH	Ch0	_Fxy_CH0_CP0_MAX	12
					Ch1	_Fxy_CH1_CP0_MAX	37
	DATA	DWORD	Sampling Comp Max. setting value -2,147,483,648 ~ 2,147,483,647				
	Output	DONE	BOOL	Execution status	If it completes, it outputs 1 and holds. If error occurs, it outputs 0		
		STAT	USINT	Error status	In case of error, outputs error code		

(g) Conversion program of Comp reference value (Single Comp) / Min. value (Sampling Comp) of Comp Output 1 and Comp Max. value (Sampling Comp) of Comp output 0

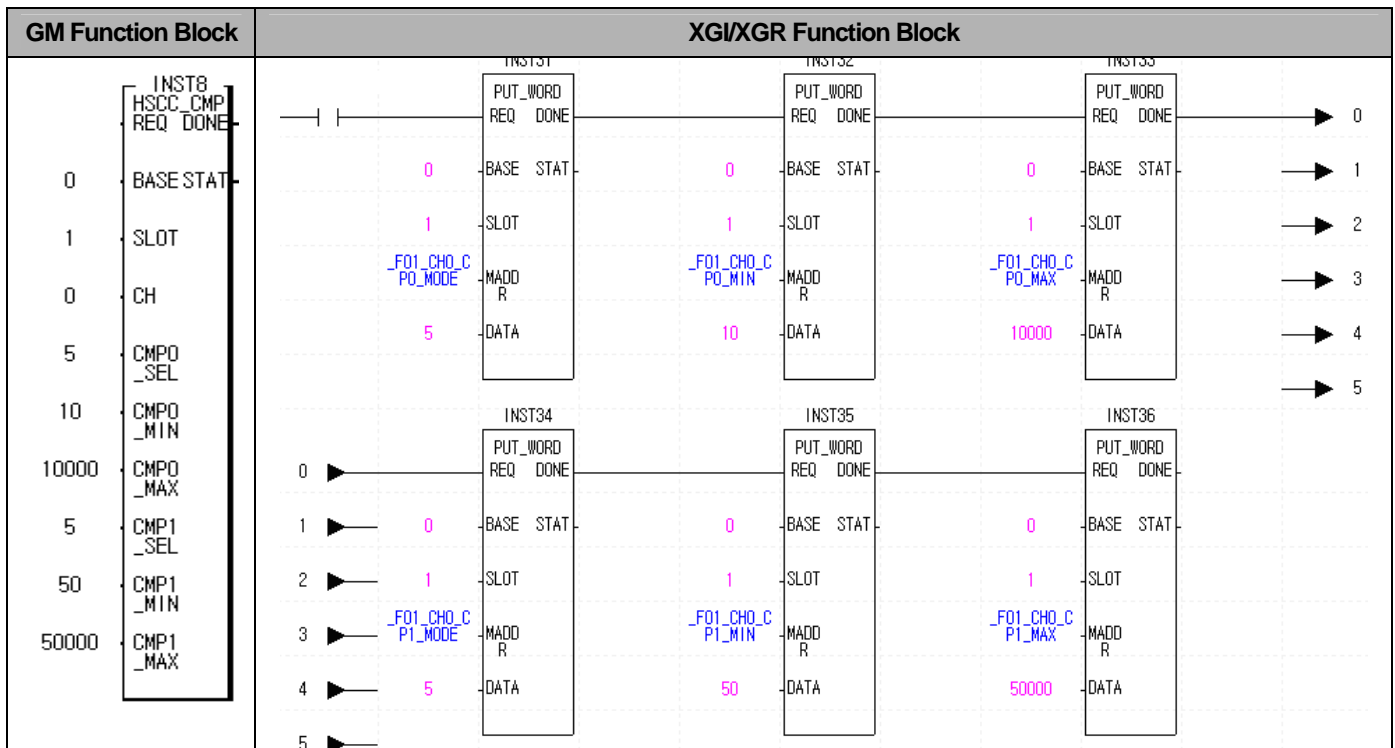

Appendix 3 GM Function Block Conversion Program

5. Count Read Function Block

(1) Count Read Function Block of GM (HSCC_CNT)

- Count Read Function Block indicates the count about current count and auxiliary function.

FB type	Classification	Variable name	Type	Content		
INST4 HSCC_CNT REQ_DONE BASE_STAT SLOT_CNT CH LTCH _CNT SMPPL _CNT IN_F REQ RPU	Input	REQ	BOOL	FB execution		
		BASE	USINT	Base Number		
		SLOT	USINT	Slot Number		
		CH	BOOL	CH	Ch0	0
					Ch1	1
	Output	DONE	BOOL	Execution status		If it completes, it outputs 1 and holds. If error occurs, it outputs 0
		STAT	USINT	Error status		In case of error, outputs error code
		CNT	DINT	Current Count		-2,147,483,648 ~ 2,147,483,647
		LTCH_CNT	DINT	Count Latch		-2,147,483,648 ~ 2,147,483,647
		SMPPL_CNT	DINT	Sampling Count		-2,147,483,648 ~ 2,147,483,647
IN_FREQ		UDINT	Measure input Freq.		0 ~ 2,147,483,647	
	RPU	UDINT	Revolution/Unit time		0 ~ 2,147,483,647	

(2) Count Read Function Block of XGI/XGR

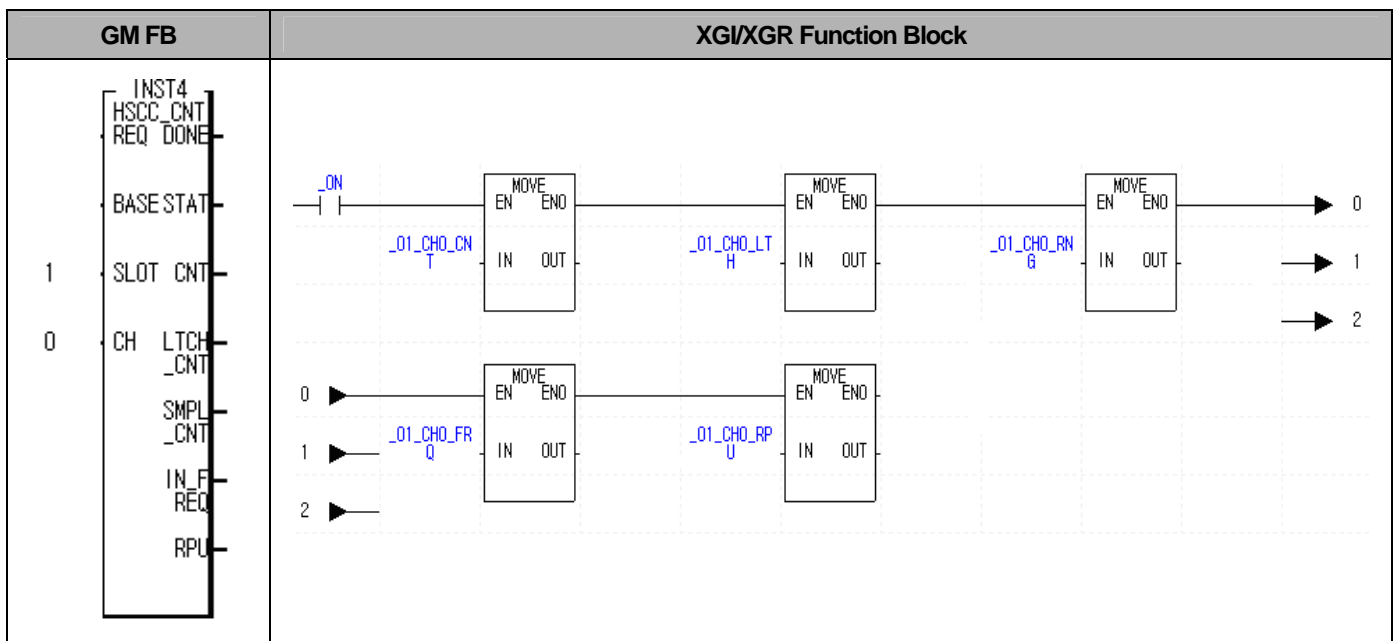

6. Operation Information setting Function Block

(1) Operation Information setting Function Block (HSCC_WR)

- Operation Information setting Function Block (HSCC_WR) executes the detection flag status setting of external preset command, internal/external use of auxiliary function enable and Up/Down count by program, Enable auxiliary function, Carry/Burrow status setting, preset.

FB Type	Classification	Variable name	Type	Contents		
<div style="border: 1px solid black; padding: 5px; width: fit-content;"> INST5 HSCC_WR REQ DONE BASE STAT SLOT CH CNT_E PRE_E DOWN_SEL AUX_E CYBW_RST PRE_I/E AUX_I/E PRE_RST </div>	Input	REQ	BOOL	FB execution	Executed when changing "0->1" (\uparrow : Rising edge)	
		BASE	USINT	Base Number	Base number where HSC module is equipped	
		SLOT	USINT	Slot Number	Slot number where HSC module is equipped	
		CH	BOOL	CH	Ch0	0
					Ch1	1
		CNT_E	BOOL	Enable/Disable of Count <ul style="list-style-type: none"> • If it is "0", disable of count • If it is "1", enable of count 		
		PRE_E	BOOL	Enable/Disable Preset operation <ul style="list-style-type: none"> • If it is "0", disable of preset • If it is "1", Enable of preset 		
		DOWN_SEL	BOOL	Up/Down count by program <ul style="list-style-type: none"> • If it is "0", Up count • If it is "1", Down count 		
		AUX_E	BOOL	Enable/Disable of auxiliary function <ul style="list-style-type: none"> • If it is "0", disable of auxiliary function • If it is "1", enable of auxiliary function 		
		CYBW_RST	BOOL	When Carry/Burrow occurs, it controls output status of Carry/Burrow of operation information read FB <ul style="list-style-type: none"> • If it is "0", it holds status of CY, BW as 1 • If it is "1", it holds status of CY, BW as 0 		
		PRE_I/E	BOOL	Internal/external use of Preset Enable <ul style="list-style-type: none"> • If it is "0", it uses by using internal FB. • If it is "1", it uses by using external input signal 		
		AUX_I/E	BOOL	Internal/External use of auxiliary function Enable <ul style="list-style-type: none"> • If it is "0", it uses by using internal FB • If it is "1", it uses by using external input signal 		
		PRE_RST	BOOL	Controls detection status of external preset input signal <ul style="list-style-type: none"> • If it is "0", it holds detection status as 1 • If it is "1", it resets detection status 		
	Output	DONE	BOOL	Execution status	If it completes, it outputs 1 and holds. If error occurs, it outputs 0	
STAT		USINT	Error status	In case of error, outputs error code		

Appendix 3 GM Function Block Conversion Program

(2) XGI/XGR Operation Information setting FB conversion program

(a) Enable/Disable count

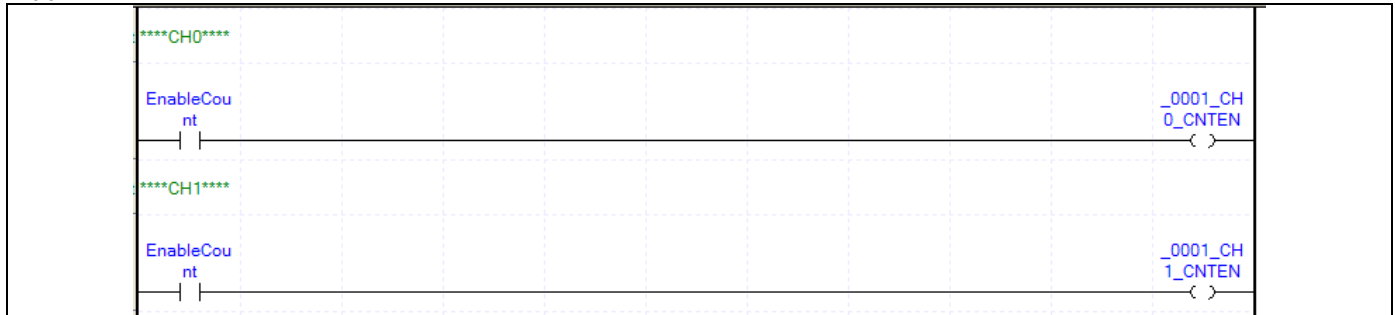

(b) Enable/Disable preset operation

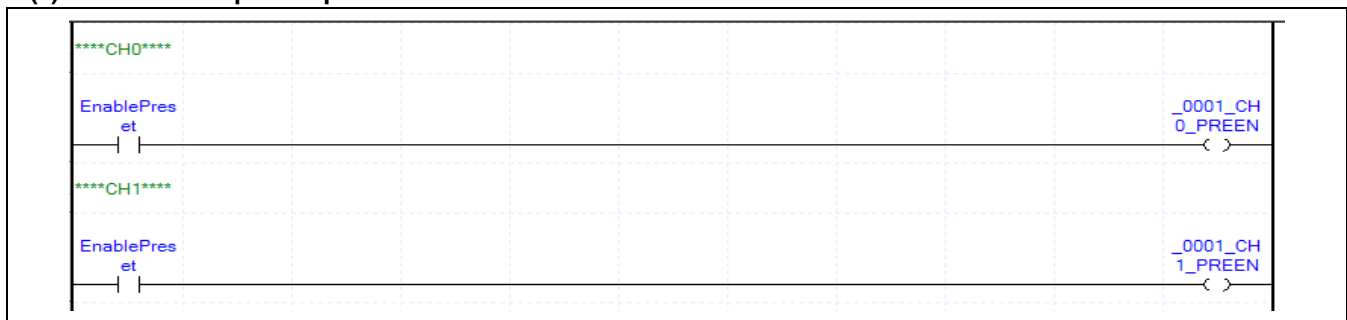

(c) Up/Down count by program

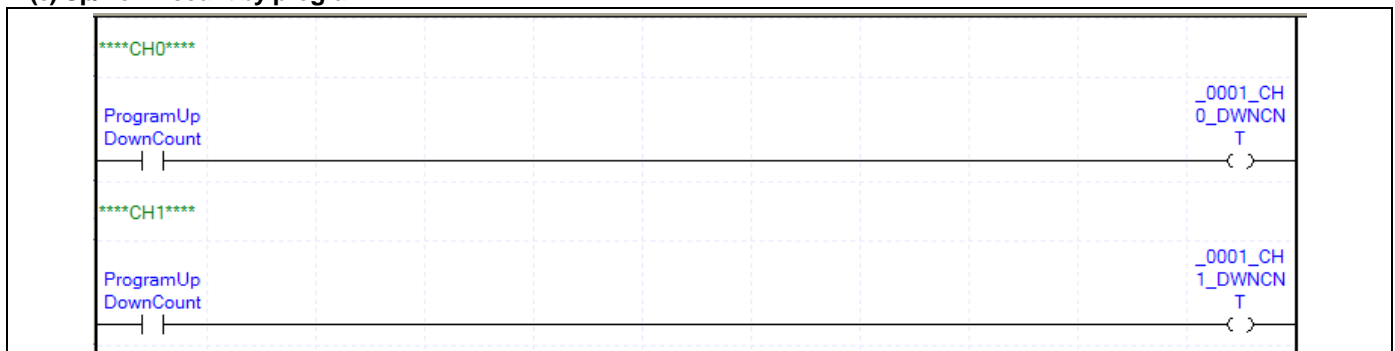

(d) Carry/Borrow detection reset

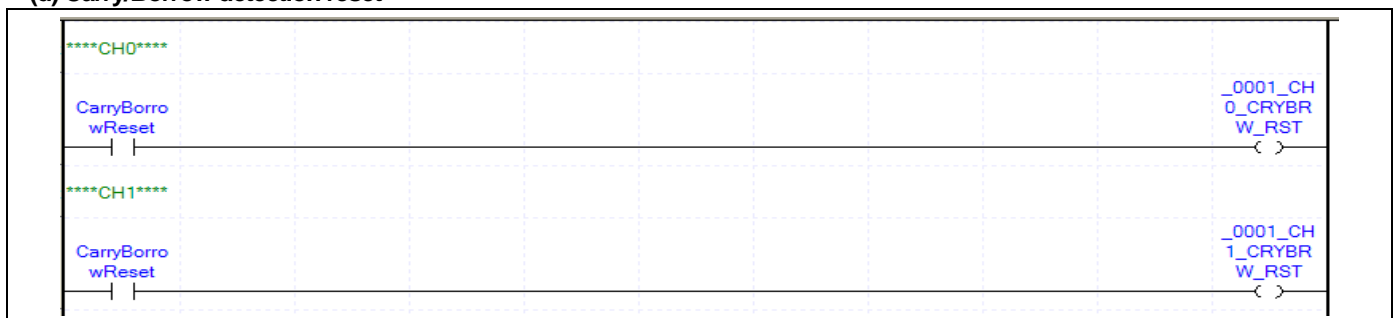

(e) External use of Enable Preset

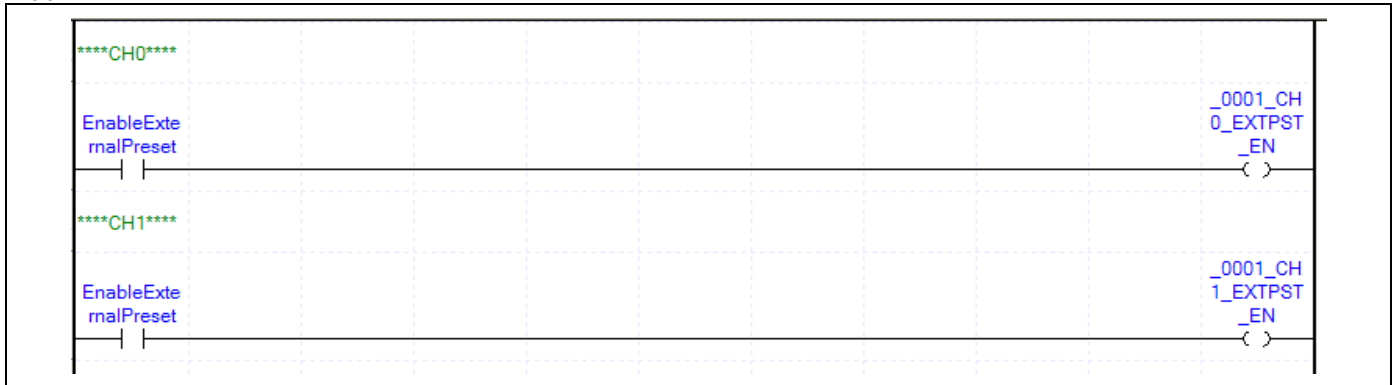

(f) External preset detection reset

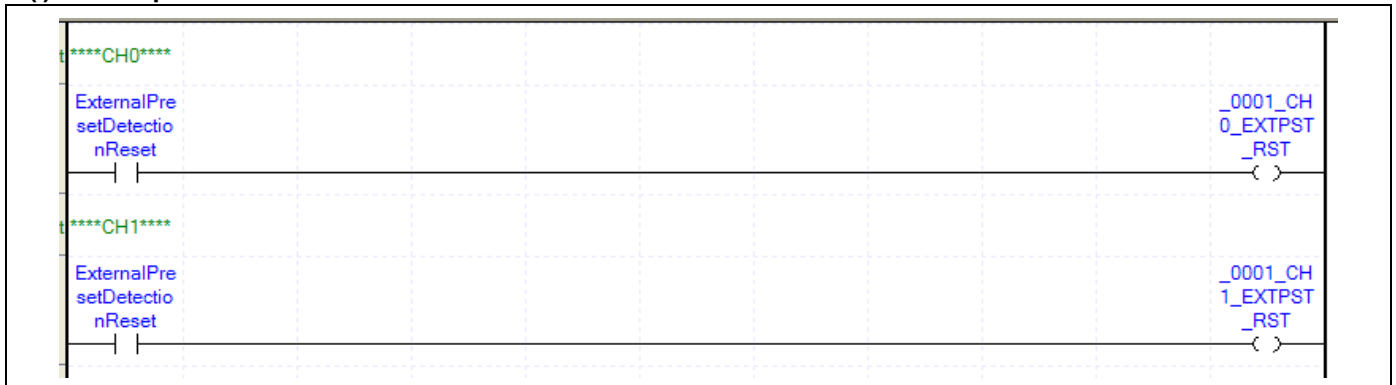

Appendix 3 GM Function Block Conversion Program

7. Operation status Read Function Block

(1) Operation status read Function Block of GM (HSCC_RD)

- Operation status read Function Block indicates Up/Down status of count, detection status of external preset input signal, Carry/Borrow status and auxiliary function operation status.

FB type	Classification	Variable name	Type	Contents
	Input	REQ	BOOL	Execution of FB Executed when changing "0->1" (: Rising edge)
		BASE	USINT	Base number (1) Base number where HSC module is equipped (2) Setting range (a) GM4 series: 0 ~ 3(GM4-CPUC: 0 ~ 7) (b) GM6 series: 0 (12 slot base: 0 ~ 1)
		SLOT	USINT	Slot number (1) Slot number where HSC module is equipped (2) Setting range: 0 ~7
		CH	BOOL	Used channel 0: CH 0, 1: CH 1
	Output	DONE	BOOL	FB execution completion status If it completes without error, it outputs "1" and holds "1" until next execution. If error occurs, it outputs "0".
		STAT	USINT	Error status In case of error, outputs error code
		DOWN_FLG	BOOL	Count operation status 0: Now increasing count, 1: Now decreasing count
		EXT_PRE	BOOL	External preset detection status 0: External preset signal is Off or reset of external preset detection is executed. 1: External preset signal is On or reset of external preset detection is not executed.
		CY	BOOL	Carry Detection Status 0: Carry not occurred, 1: Carry occurred
		BW	BOOL	Borrow Detection Status 0: Borrow not occurred, 1: Borrow occurred
		AUX_ING	BOOL	Auxiliary Function Operation Status 0: Auxiliary function not occurred, 1: Auxiliary function occurred

(2) XGI/XGR Operation Information setting FB conversion Program

(a) Count operation status

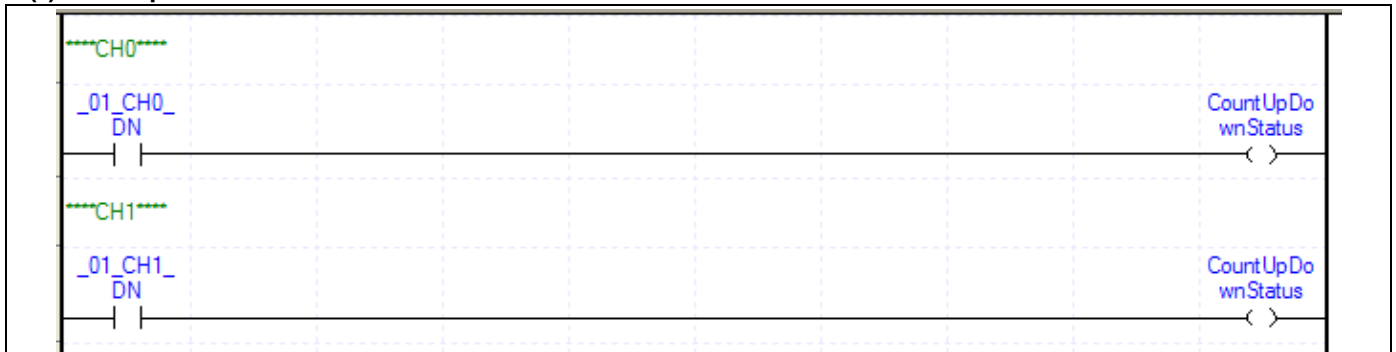

(b) External Preset Input Detection

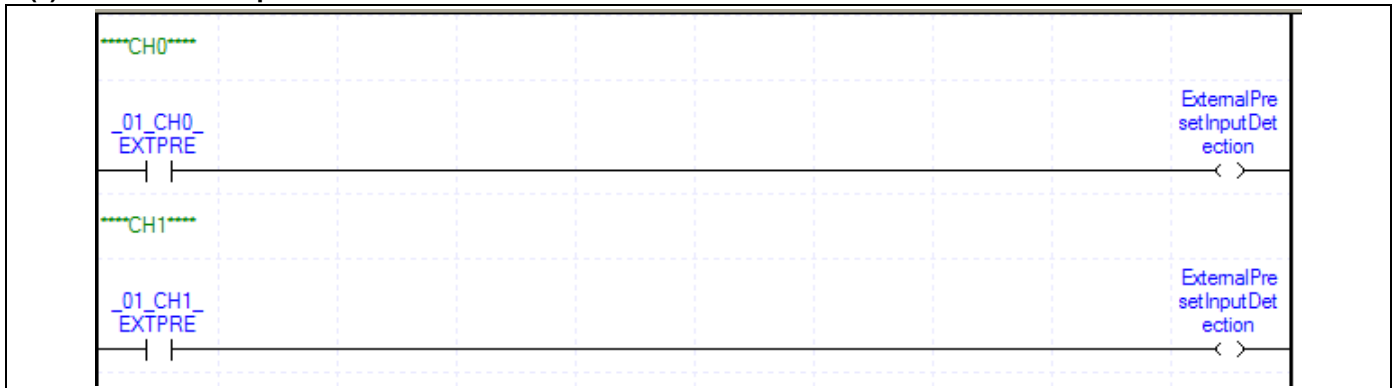

(c) Carry Detection

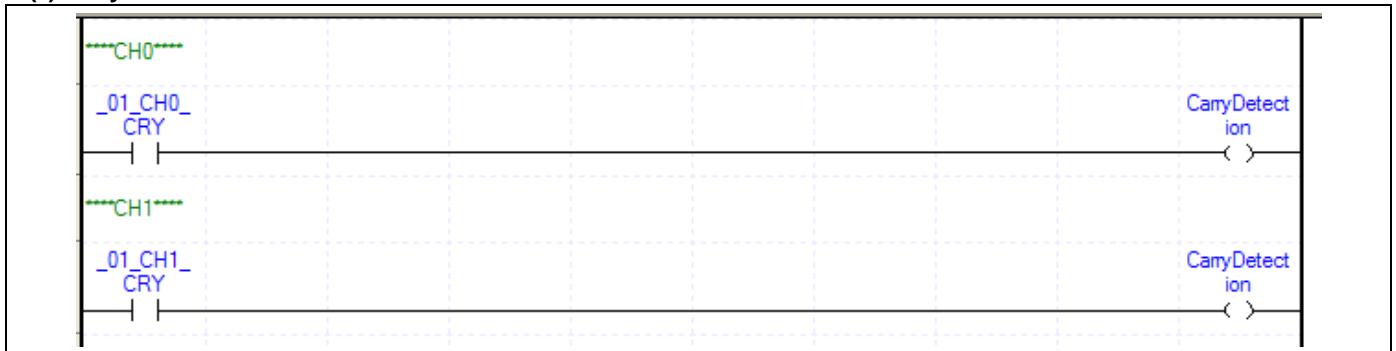

(d) Borrow Detection

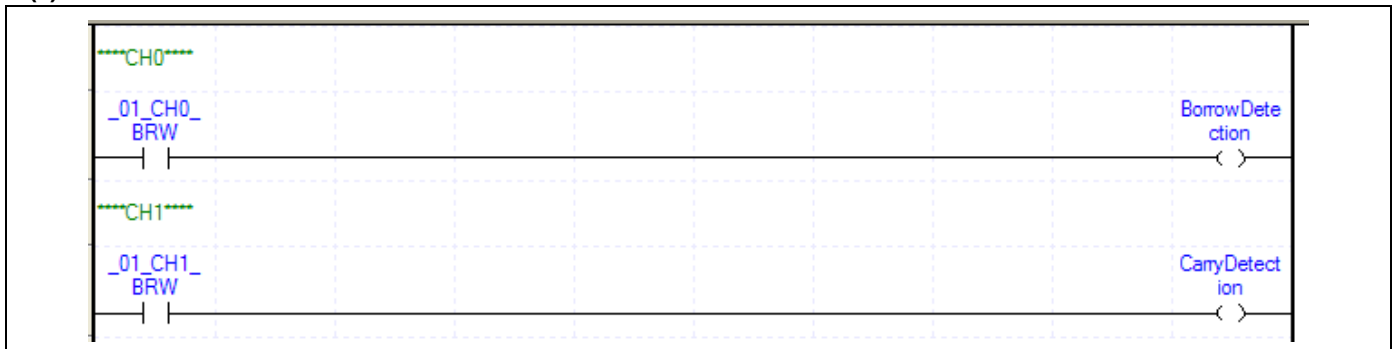

Appendix 3 GM Function Block Conversion Program

(e) Auxiliary Function Operating

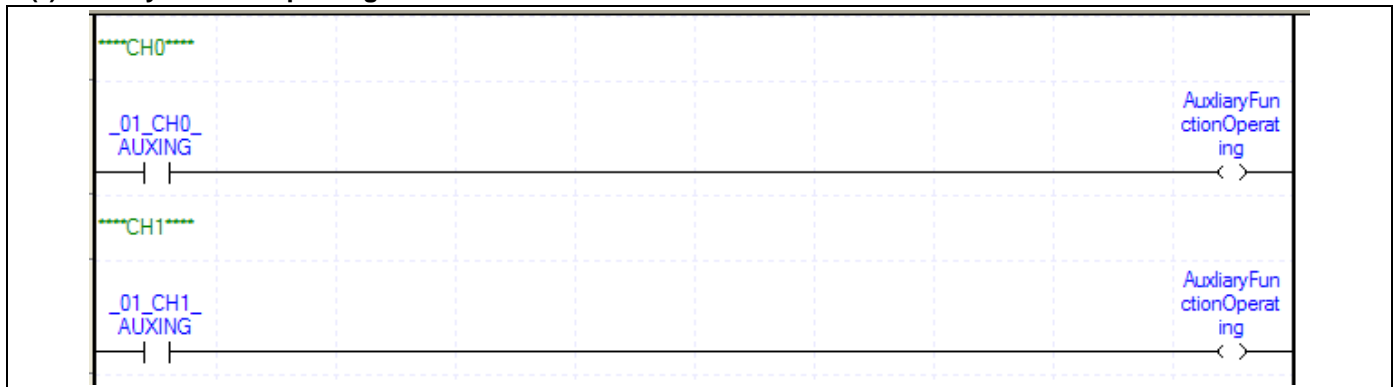

8. Comp Output Setting Function Block

(1) Comp Output Setting Function Block of GM (HSCC_OUT)

- Comp output Setting Function Block sets comparison of HSC module and enable of comparison output, agreement reset, whether to hold comparison output (OUT0, OUT1) and indicates status of comparison output

FB type	Classification	Variable name	Data type	Contents
<p>The diagram shows the HSCC_OUT function block with the following variables:</p> <ul style="list-style-type: none"> Inputs: INST?, HSCC_OUT_REQ, DONE, BASE_STAT, SLOT_CMP0_OUT, CH_CMP1_OUT, CMP_E, OUT_E, EQ0_RST, EQ1_RST, STOP_SEL. Outputs: DONE, STAT, CMP0_OUT, CMP1_OUT. 	Input	REQ	BOOL	Execution of FB Executed when changing "0->1" (\uparrow : Rising edge)
		BASE	USINT	Base Number (1) Base number where HSC module is equipped. (2) Setting range (a) GM4 series: 0 ~ 3(GM4-CPUC: 0 ~ 7) (b) GM6 series: 0(12 slot base: 0 ~ 1)
		SLOT	USINT	Slot number (1) Slot number where HSC module is equipped. (2) Setting range: 0 ~7
		CH	BOOL	Used channel 0: CH 0, 1: CH 1
		CMP_E	BOOL	Enable comparison 0: Disable comparison, 1: Enable comparison
		OUT_E	BOOL	Enable Comp output 0: Disable comp output, 1: Enable comp output
		EQ0_RST	BOOL	Comp agreement reset of Comp Output (CMP0_OUT) 0: holds agreement status of comp output 0 as 1 (On) 1: holds agreement status of comp output 0 as 0 (Off)
		EQ1_RST	BOOL	Comp agreement reset of Comp Output (CMP1_OUT) 0: holds agreement status of comp output 0 as 1 (On) 1: holds agreement status of comp output 0 as 0 (Off)
		STOP_SEL	BOOL	Comp output status 0: when PLC CPU is STOP, disables comp output 1: when PLC CPU is STOP, holds comp output
	Output	DONE	BOOL	Function Block execution completion status If it completes without error, it outputs "1" and holds "1" until next execution. If error occurs, it outputs "0".
		STAT	USINT	Error status In case of error, outputs error code
		CMP0_OUT	BOOL	Status of Comp Output 0 0: Off(0), 1: On(1)
		CMP1_OUT	BOOL	Status of Comp Output 1 0: Off(0), 1: On(1)

Warranty

1. Warranty Period

The product you purchased will be guaranteed for 18 months from the date of manufacturing.

2. Scope of Warranty

Any trouble or defect occurring for the above-mentioned period will be partially replaced or repaired. However, please note the following cases will be excluded from the scope of warranty.

- (1) Any trouble attributable to unreasonable condition, environment or handling otherwise specified in the manual,
- (2) Any trouble attributable to others' products,
- (3) If the product is modified or repaired in any other place not designated by the company,
- (4) Due to unintended purposes
- (5) Owing to the reasons unexpected at the level of the contemporary science and technology when delivered.
- (6) Not attributable to the company; for instance, natural disasters or fire

3. Since the above warranty is limited to PLC unit only, make sure to use the product considering the safety for system configuration or applications.

Environmental Policy

LS Industrial Systems Co., Ltd supports and observes the environmental policy as below.

Environmental Management

LS Industrial Systems considers the environmental preservation as the preferential management subject and every staff of LS Industrial Systems use the reasonable endeavors for the pleasurable environmental preservation of the earth.

About Disposal

LS Industrial Systems' PLC unit is designed to protect the environment. For the disposal, separate aluminum, iron and synthetic resin (cover) from the product as they are reusable.



LS values every single customers.
 Quality and service come first at LSIS.
 Always at your service, standing for our customers.

www.lsis.biz

LS Industrial Systems

10310000610

■ **HEAD OFFICE**

LS tower, Hogye-dong, Dongan-gu, Anyang-si, Gyeonggi-do
 1026-6, Korea <http://eng.lsis.biz>
 Tel. (82-2)2034-4689, 4888 Fax.(82-2)2034-4648

■ **LS Industrial Systems Tokyo Office >> Japan**

Address: 16F, Higashi-Kan, Akasaka Twin Towers 17- 22,
 2-chome, Akasaka, Minato-ku, Tokyo 107-8470, Japan
 Tel: 81-3-3582-9128 Fax: 81-3-3582-2667

e-mail: jschuna@lsis.biz

■ **LS Industrial Systems Dubai Rep. Office >> UAE**

Address: P.O.BOX-114216, API World Tower, 303B, Sheikh
 Zayed road, Dubai, UAE. e-mail: hwyim@lsis.biz
 Tel: 971-4-3328289 Fax: 971-4-3329444

■ **LS-VINA Industrial Systems Co., Ltd. >> Vietnam**

Address: LSIS VINA Congty che tao may dien Viet-Hung
 Dong Anh Hanoi, Vietnam e-mail: srjo@hn.vnn.vn
 Tel: 84-4-882-0222 Fax: 84-4-882-0220

■ **LS Industrial Systems Hanoi Office >> Vietnam**

Address: Room C21, 5th Floor, Horizon Hotel, 40 Cat Linh,
 Hanoi, Vietnam
 Tel: 84-4-736-6270/1 Fax: 84-4-736-6269

■ **Dalian LS Industrial Systems Co., Ltd. >> China**

Address: No. 15 Liaohexi 3 Road, economic and technical
 development zone, Dalian, China e-mail: lixk@lqis.com.cn
 Tel: 86-411-8273-7777 Fax: 86-411-8730-7560

■ **LS Industrial Systems (Shanghai) Co., Ltd. >> China**

Address: Room E-G, 12th Floor Huamin Empire Plaza,
 No. 726, West Yan'an Road, Shanghai, China
 Tel: 86-21-5237-9977

■ **LS Industrial Systems(Wuxi) Co., Ltd. >> China**

Address: 102-A National High & New Tech Industrial
 Development Area, Wuxi, Jiangsu, China e-mail: Xugh@lqis.com.cn
 Tel: 86-510-534-6666 Fax: 86-510-522-4078

■ **LS Industrial Systems Beijing Office >> China**

Address: B-tower 17th Floor, Beijing Global Trade Center building,
 No. 36, BeiSanHuanDong-Lu, DongCheng-District, Beijing, China
 Tel: 86-10-5825-6025

■ **LS Industrial Systems Guangzhou Office >> China**

Address: Room 1403, 14F, New Poly Tower, 2 Zhongshan Liu
 Rad, Guangzhou, China e-mail: zhangch@lqis.com.cn
 Tel: 86-20-8326-6754 Fax: 86-20-8326-6287

■ **LS Industrial Systems Chengdu Office >> China**

Address: Room 2907, Zhong Yin B/D, No. 35, Renminzhong(2)-
 Road, Chengdu, China e-mail: hongkonk@vip.163.com
 Tel: 86-28-8612-9151 Fax: 86-28-8612-9236

■ **LS Industrial Systems Qingdao Office >> China**

Address: 12th Floor, Guodong building, No52 Jindun Road,
 Chengdu, China e-mail: bellkuk@hanmail.net
 Tel: 86-532-580-2539 Fax: 86-532-583-3793

※ LS Industrial Systems constantly endeavors to improve its product so that
 Information in this manual is subject to change without notice.
 © LS Industrial Systems Co., Ltd 2006 All Rights Reserved.