

Right choice for ultimate yield

LSIS strives to maximize customers' profit in gratitude of choosing us for your partner.

Programmable Logic Controller

Pnet Remote I/F Module

XGT Series

User's Manual

XGL-PSRA



Safety Instructions

- Read this manual carefully before installing, wiring, operating, servicing or inspecting this equipment.
- Keep this manual within easy reach for quick reference.

LS Industrial Systems

<http://eng.lsis.biz>

Before using the product ...

For your safety and effective operation, please read the safety instructions thoroughly before using the product.

- ▶ Safety Instructions should always be observed in order to prevent accident or risk with the safe and proper use the product.
- ▶ Instructions are divided into “Warning” and “Caution”, and the meaning of the terms is as follows.

 **Warning** This symbol indicates the possibility of serious injury or death if some applicable instruction is violated

 **Caution** This symbol indicates the possibility of severe or slight injury, and property damages if some applicable instruction is violated

Moreover, even classified events under its caution category may develop into serious accidents relying on situations. Therefore we strongly advise users to observe all precautions properly just like warnings.

- ▶ The marks displayed on the product and in the user’s manual have the following meanings.

 Be careful! Danger may be expected.

 Be careful! Electric shock may occur.

- ▶ The user’s manual even after read shall be kept available and accessible to any user of the product.

Safety Instructions for design process

Warning

- ▶ **Please install a protection circuit on the exterior of PLC so that the whole system may operate safely regardless of failures from external power or PLC.** Any abnormal output or operation from PLC may cause serious problems to safety in whole system.
 - Install protection units on the exterior of PLC like an interlock circuit that deals with opposite operations such as emergency stop, protection circuit, and forward/reverse rotation or install an interlock circuit that deals with high/low limit under its position controls.
 - If any system error (watch-dog timer error, module installation error, etc.) is detected during CPU operation in PLC, all output signals are designed to be turned off and stopped for safety. However, there are cases when output signals remain active due to device failures in Relay and TR which can't be detected. Thus, you are recommended to install an addition circuit to monitor the output status for those critical outputs which may cause significant problems.
- ▶ **Never overload more than rated current of output module nor allow to have a short circuit.** Over current for a long period time may cause a fire .
- ▶ **Never let the external power of the output circuit to be on earlier than PLC power,** which may cause accidents from abnormal output operation.
- ▶ **Please install interlock circuits in the sequence program for safe operations in the system when exchange data with PLC or modify operation modes using a computer or other external equipments** Read specific instructions thoroughly when conducting control operations with PLC.

Safety Instructions for design process

Caution

- ▶ **I/O signal or communication line shall be wired at least 100mm away from a high-voltage cable or power line. Fail to follow this**

Safety Instructions on installation process

Caution

- ▶ **Use PLC only in the environment specified in PLC manual or general standard of data sheet.** If not, electric shock, fire, abnormal operation of the product may be caused.
- ▶ **Before install or remove the module, be sure PLC power is off.** If not, electric shock or damage on the product may be caused.
- ▶ **Be sure that every module is securely attached after adding a module or an extension connector.** If the product is installed loosely or incorrectly, abnormal operation, error or dropping may be caused. In addition, contact failures under poor cable installation will be causing malfunctions as well.
- ▶ **Be sure that screws get tighten securely under vibrating environments.** Fail to do so will put the product under direct vibrations which will cause electric shock, fire and abnormal operation.
- ▶ **Do not come in contact with conducting parts in each module,** which may cause electric shock, malfunctions or abnormal operation.

Safety Instructions for wiring process

Warning

- ▶ **Prior to wiring works, make sure that every power is turned off.** If not, electric shock or damage on the product may be caused.
- ▶ **After wiring process is done, make sure that terminal covers are installed properly before its use.** Fail to install the cover may cause electric shocks.

Caution

- ▶ **Check rated voltages and terminal arrangements in each product prior to its wiring process.** Applying incorrect voltages other than rated voltages and misarrangement among terminals may cause fire or malfunctions.
- ▶ **Secure terminal screws tightly applying with specified torque.** If the screws get loose, short circuit, fire or abnormal operation may be caused. Securing screws too tightly will cause damages to the module or malfunctions, short circuit, and dropping.
- ▶ **Be sure to earth to the ground using Class 3 wires for FG terminals which is exclusively used for PLC.** If the terminals not grounded correctly, abnormal operation or electric shock may be caused.
- ▶ **Don't let any foreign materials such as wiring waste inside the module while wiring,** which may cause fire, damage on the product or abnormal operation.
- ▶ **Make sure that pressed terminals get tighten following the specified torque. External connector type shall be pressed or soldered using proper equipments.**

Safety Instructions for test-operation and maintenance

Warning

- ▶ **Don't touch the terminal when powered.** Electric shock or abnormal operation may occur.
- ▶ **Prior to cleaning or tightening the terminal screws, let all the external power off including PLC power.** If not, electric shock or abnormal operation may occur.
- ▶ **Don't let the battery recharged, disassembled, heated, short or soldered.** Heat, explosion or ignition may cause injuries or fire.

Caution

- ▶ **Do not make modifications or disassemble each module.** Fire, electric shock or abnormal operation may occur.
- ▶ **Prior to installing or disassembling the module, let all the external power off including PLC power.** If not, electric shock or abnormal operation may occur.
- ▶ **Keep any wireless equipment such as walkie-talkie or cell phones at least 30cm away from PLC.** If not, abnormal operation may be caused.
- ▶ **When making a modification on programs or using run to modify functions under PLC operations, read and comprehend all contents in the manual fully.** Mismanagement will cause damages to products and accidents.
- ▶ **Avoid any physical impact to the battery and prevent it from dropping as well.** Damages to battery may cause leakage from its fluid. When battery was dropped or exposed under strong impact, never reuse the battery again. Moreover skilled workers are needed when exchanging batteries.

Safety Instructions for waste disposal



Caution

- ▶ **Product or battery waste shall be processed as industrial waste.** The waste may discharge toxic materials or explode itself.

Revision History

Version	Date	Contents	Revised position
V 1.0	'10.6	First edition	-

※ The number of User's manual is indicated right part of the back cover.

© 2009 LS Industrial Systems Co., Ltd All Rights Reserved.

Thank you for purchasing PLC of LS Industrial System Co.,Ltd.

Before use, make sure to carefully read and understand the User's Manual about the functions, performances, installation and programming of the product you purchased in order for correct use and importantly, let the end user and maintenance administrator to be provided with the User's Manual.

The User's Manual describes the product. If necessary, you may refer to the following description and order accordingly. In addition, you may connect our website (<http://eng.lsis.biz/>) and download the information as a PDF file.

Relevant User's Manuals

Title	Description
XG5000 User's Manual (for XGK, XGB)	XG5000 software user manual describing online function such as programming, print, monitoring, debugging by using XGK, XGB CPU
XG5000 User's Manual (for XGI, XGR)	XG5000 software user manual describing online function such as programming, print, monitoring, debugging by using XGI, XGR CPU
XGK/XGB Instructions & Programming User's Manual	User's manual for programming to explain how to use instructions that are used PLC system with XGK, XGB CPU.
XGI/XGR/XEC Instructions & Programming User's Manual	User's manual for programming to explain how to use instructions that are used PLC system with XGI, XGR, XEC CPU.
XGK CPU User's Manual (XGK-CPUA/CPUE/CPUH/CPUS/CPUU)	XGK-CPUA/CPUE/CPUH/CPUS/CPUU user manual describing about XGK CPU module, power module, base, IO module, specification of extension cable and system configuration, EMC standard
XGI CPU User's Manual (XGI-CPUU/CPUH/CPUS)	XGI-CPUU/CPUH/CPUS user manual describing about XGI CPU module, power module, base, IO module, specification of extension cable and system configuration, EMC standard
XGR redundant series User's Manual	XGR- CPUH/F, CPUH/T user manual describing about XGR CPU module, power module, extension drive, base, IO module, specification of extension cable and system configuration, EMC standard
PROFICON User's Manual	PROFICON software user manual describing about how to use PROFICON software tool for Profibus setup of XGL-PMEC, G4L-PUEC

© Contents ©

Chapter 1 Overview 1-1 ~ 1-7

1.1 How to use the user's manual	1-1
1.2 Characteristics of Pnet remote I/F module	1-3
1.3 Product configuration of Pnet remote I/F module	1-4
1.3.1 Product Configuration.....	1-4
1.4 Pnet Remote I/F Module Version Compatibility List	1-6
1.5 Notice in Using	1-7

Chapter 2 Product Specification 2-1 ~ 2-4

2.1 General Specifications	2-1
2.2 Communication Module Specification	2-2
2.2.1 Pnet remote I/F module specification	2-2
2.3 Communication Cable Specification	2-3
2.3.1 Profibus-DP cable specification.....	2-3
2.4 Terminating.....	2-4
2.4.1 Pnet Terminating	2-4

Chapter 3 System Configuration 3-1 ~ 3-8

3.1 Notices in Selecting Module.....	3-1
3.2 Names of Each Part	3-2
3.2.1 Basic System Configuration	3-2
3.2.2 Names and Functions of Each Part.....	3-2
3.2.3 Available Product List	3-4
3.3 System Configuration Example.....	3-7
3.3.1 Pnet System (GMWIN)	3-7
3.3.2 Pnet system (XG5000)	3-8

Chapter 4 Communication Programming..... 4-1 ~ 4-10

4.1 How to Set Master Module	4-1
4.1.1 High-speed Link.....	4-1
4.1.2 XG-PD's Link Parameter Setting	4-2
4.1.3 High-speed Link communication status flag information (XGT).....	4-4
4.2 How to register XGT Profibus-DP remote module	4-6
4.2.1 Create new project	4-6
4.2.2 Set IO parameter	4-7

Chapter 5 Profibus-DP Communication 5-1 ~ 5-39

5.1 Overview.....	5-1
5.2 Communication Specification	5-1
5.3 Basic Performance	5-2
5.3.1 Overview	5-2
5.3.2 Operation by <i>High-speed Link</i>	5-2
5.3.3 Procedure to establish Pnet communication	5-3
5.3.4 I/O Data Communication	5-4
5.4 Tool for Communication Setting.....	5-5
5.4.1 Communication Setting by SyCon.....	5-5
5.4.2 Communication Setting through PROFICON.....	5-13
5.5 High Speed Link Setting.....	5-22
5.5.1 High Speed Link Setting in GMWIN	5-22
5.5.2 High-speed Link Parameter Setting in KGLWIN	5-29
5.5.3 High Speed Link Setting in XG-PD.....	5-32
5.5.4 How to set GSD and downloading procedure	5-39

Chapter 6 Installation and Wiring 6-1 ~ 6-10

6.1 Installation.....	6-1
6.1.1 Installation Environment.....	6-1
6.1.2 Notices in installing Profibus-DP module.....	6-2
6.1.3 Notices in Handling.....	6-3

6.2 Wiring.....	6-7
6.2.1 Power Wiring.....	6-7
6.2.2 I/O Device Wiring.....	6-9
6.2.3 Grounding Wiring.....	6-9
6.2.4 Cable Specification for Wiring.....	6-10

Chapter 7 Maintenance and Repair	7-1 ~ 7-3
---	------------------

7.1 Repair and Check.....	7-1
7.2 Daily Check	7-2
7.3 Regular Check	7-3

Chapter 8 Trouble Shooting	8-1 ~ 8-20
---	-------------------

8.1 Basic Procedure of Trouble Shooting.....	8-1
8.2 Trouble Shooting.....	8-2
8.2.1 Action method when RUN LED is OFF.....	8-3
8.2.2 Action method when ERR LED is ON.....	8-4
8.2.3 Action method when I/O part does not work normally.	8-5
8.2.4 Action method when <i>Program Write</i> does not work.....	8-7
8.2.5 SyCon connection error	8-8
8.2.6 XG-PD connection error	8-9
8.2.7 Communication error with slave.....	8-10
8.2.8 Analog Module's Channel Error Diagnosis Function	8-11
8.2.9 Trouble Shooting Questionnaire	8-20

Chapter 1 Overview

1.1 How to use the user's manual

This User's Manual provides the information such as product specification, performance and operation method needed to use PLC System composed of Pnet remote I/F module.

The User's Manual is composed of as follows.

CHAP.1 Overview

Describes the configuration of the user's manual, product characteristics and terminology

CHAP.2 Product Specification

Describes common specification of each product used for Pnet remote I/F module

CHAP.3 System Configuration

Describes the kinds of product available for Pnet remote I/F module and system configuration method

CHAP.4 Communication Programming

Describes common communication program operating method to act Pnet remote I/F module

CHAP.5 Profibus-DP Communication

Describes basic communication method of Profibus-DP (from now on referred to as Pnet) communication module

CHAP.6 Installation and Wiring

Describes installation and wiring method, and notices to make sure of the reliability of PLC system

CHAP.7 Maintenance and Repair

Describes check list and method to run PLC system normally for a long term.

CHAP.8 Trouble Shooting

Describes various errors to be occurred while using the system and the action to solve the problem

Appendix

Here describes the product terminology and external dimension for system installation.

Chapter 1 Overview

If you want to write programs, refer to the following manuals.

- GLOFA PLC Instruction manual
- GLOFA PLC GMWIN user manual
- GLOFA PLC GM3/4 user manual
- GLOFA PLC GM6 user manual

- MASTER-K Instruction
- MASTER-K 200S/300S user manual
- KGLWIN user manual

- XG5000 user manual
- XGK Instruction manual
- XGI/XGR Instruction manual
- XGK CPU manual
- XGI/XGR CPU manual
- XGT Pnet I/F module user manual

When you make system of GLOFA-GM/MASTER-K and Smart I/O module, consider the followings. The following is CPU or software version for operating the module.

- GLOFA PLC GMWIN program Tool: upper Ver.4.03
- GLOFA GMR CPU : more than Ver. 2.2
- GLOFA GM1/2 CPU : more than Ver. 3.2
- GLOFA GM3 CPU : more than Ver. 2.7
- GLOFA GM6 CPU : more than Ver. 2.1

- MASTER-K PLC KGLWIN programming Tool : more than Ver. 3.41
- MASTER-K K1000S CPU : more than Ver. 3.2
- MASTER-K K300S CPU : more than Ver. 3.4
- MASTER-K K200S CPU : more than Ver. 2.4

- Frame Editor : more than Ver. 2.01

Remark

1) This manual is written for GMWIN V4.04, KGLWIN V3.6, Frame editor V2.01 and XG5000 V2.0.

1.2 Characteristics of Pnet remote I/F module

The characteristics of Pnet remote I/F module is as follows.

- (1) Product design based on International Electrotechnical Commission (IEC 61131) (GLOFA series in common)
 - Easy support to programming device
 - Standard language (IEC 61131-3) provided (IL / LD / SFC)
- (2) Open network by selecting international standard communication protocol.
- (3) Available to communicate with remote master module
- (4) Available to set maximum 99 stations.
- (5) Enables to save the cost for installation and maintenance.
- (6) Various system configuration and simple maintenance and repair.
- (7) Easy to change the system.
- (8) Compatible with other maker's product.
 - Available to connect Pnet remote I/F module to other maker's master.
- (9) Easy to set the system by hardware station address setting
- (10) Simple communication programming.
 - Using the GMWIN/KGLWIN High-speed link parameter
- (11) Supports various I/O.
 - DC input 8/16/32/64 points, TR output 16/32/64 points, Relay output 8/16 points
 - Combined 32 point (DC input 16 point/ TR output 16 point)
 - Various special module such as AD(analog input)/DA(analog voltage)/DC(analog current output)/RTD(Resistor temperature detector)/TC(Thermocouple)
- (12) Easy to configure system and use
 - Various I/O configurations by user
- (13) Provides the online network status detection function.
 - Available to know the remote module status through high speed link monitor.
 - Available to check diverse module instantly.
- (14) High speed communication
- (15) Flexible communication relation is available as the speed shall be set automatically according to the speed of master.
- (16) Hot-Swap function available
 - 1) Available to change the module during RUN mode.
 - I/O modules except the module under change operate normally.
 - 2) Before change, informs the BPMC of module change by switch manipulation.
 - 3) After change, restore the mode switch.
 - 4) You can check the invalid module installation and replacement through operation of M_CHECK, M_CLO/SE at BPMC I/F program.

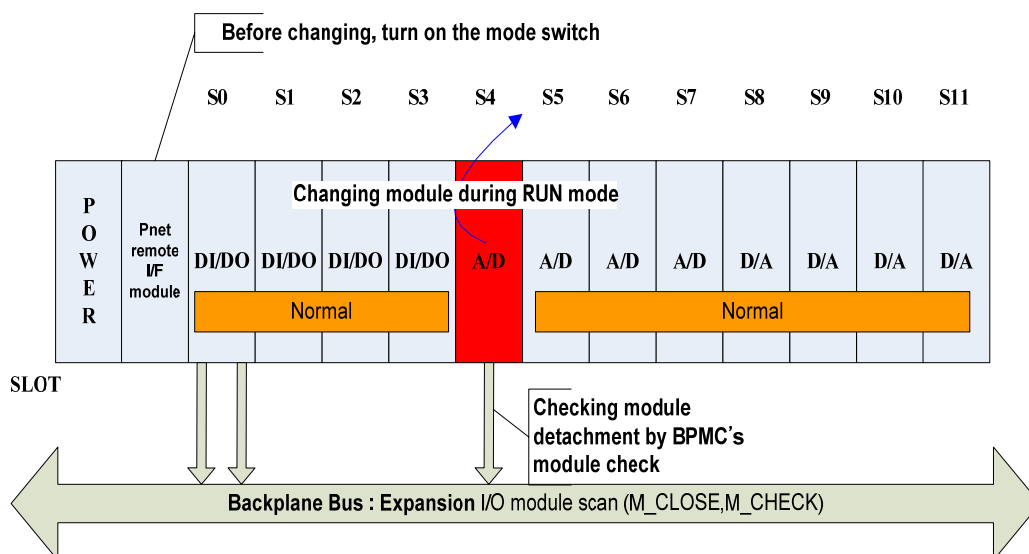

1.3 Product configuration of Pnet remote I/F module

1.3.1 Product Configuration

1) Digital I/O module

Name	Model	Contents	Remark
Digital input module	XGI-D21A	• DC 24V input, 8 points (current source / sink input)	
	XGI-D22A	• DC 24V input, 16 points (current source / sink input)	
	XGI-D24A	• DC 24V input, 32 points (current source / sink input)	
	XGI-D28A	• DC 24V input, 64 points (current source / sink input)	
	XGI-D22B	• DC 24V input, 16 points (current source input)	
	XGI-D24B	• DC 24V input, 32 points (current source input)	
	XGI-D28B	• DC 24V input, 64 points (current source input)	
	XGI-A12A	• AC 110V input, 16 points	
	XGI-A21A	• AC 220V input, 8 points	
Digital output module	XGQ-RY1A	• Relay output, 8 points (2A, single COM.)	
	XGQ-RY2A	• Relay output, 16 points (2A)	
	XGQ-RY2B	• Relay output, 16 points (2A), Varistor added	
	XGQ-TR2A	• TR output, 16 points (0.5A, sink output)	
	XGQ-TR4A	• TR output, 32 points (0.1A, sink output)	
	XGQ-TR8A	• TR output, 64 points (0.1A, sink output)	
	XGQ-TR2B	• TR output 16 points (0.5A, source output)	
	XGQ-TR4B	• TR output 32 points (0.1A, source output)	
	XGQ-TR8B	• TR output 64 points (0.1A, source output)	
	XGQ-SS2A	• Triac output, 16 points (1A)	
Digital I/O module	XGH-DT4A	• DC 24V input, 16 points (current source / sink input) • TR output, 16 points (0.1A, sink output)	
Dustproof module	XGT-DMMA	• Dustproof module for unused slot	

2) Analog I/O module

Name	Model	Contents	Remark	
Special module	Analog input module	XGF-AV4A	• Voltage input: 4 channels	-
		XGF-AV8A	• Voltage input: 8 channels	-
		XGF-AC4A	• Current input: 4 channels	-
		XGF-AC8A	• Current input: 8 channels	-
		XGF-AD8A	• Voltage/Current input: 8 channels	-
		XGF-AD4S	• Voltage/Current input: 4 channels, Insulation between channels	-
		XGF-AW4S	• Voltage/Current input: 4 channels (2-wire input), Insulation between channels	-
		XGF-AD16A	• Voltage/Current input: 16 channels	-
	Analog output module	XGF-DV4A	• Voltage output: 4 channels • DC 1 ~ 5V / 0 ~ 5V / 0 ~ 10V / -10 ~ +10V	-
		XGF-DC4A	• Current output: 4 channels • DC 4 ~ 20mA / 0 ~ 20mA	-
		XGF-DV4S	• Voltage output: 4 channels, Insulation between channels	-
		XGF-DC4S	• Current output: 4 channels, Insulation between channels	-
		XGF-DV8A	• Voltage output: 8 channels • DC 1 ~ 5V / 0 ~ 5V / 0 ~ 10V / -10 ~ +10V	-
		XGF-DC8A	• Current output: 8 channels • DC 4 ~ 20mA / 0 ~ 20mA	-
	Analog I/O module	XGF-AH6A	• Voltage/Current input 4 channels • Voltage/Current output 2 channels	4 words are allocated for each I/O in XGL-PSRA
	Thermocouple input	XGF-TC4S	• T/C input, 4 channels, insulation between channels	-
	RTD input module	XGF-RD4A	• RTD input, 4 channels	-
		XGF-RD4S	• RTD input, 4 channels, insulation between channels	-

1.4 Pnet Remote I/F Module Version Compatibility List

The following table indicates compatible list of O/S Version between each CPU and master module to use Pnet remote I/F module. Before applying the system, refer to the following list.
In case of XGK/XGI/XGB/XGR, all versions are available.

Classification		Available Module		Ref.
		Type	O/S Version	
CPU	GM3	GM3-CPUA	Version 2.5 or later	
	GM4	GM4-CPUA/B/C	Version 2.6 or later	
	GM6	GM6-CPUA/B/C	Version 1.9 or later	
	GM7	G7M Series	Version 1.6 or later	
	K1000S	K7P-30AS	Version 3.1 or later	
	K300S	K4P-15AS	Version 3.1 or later	
	K200S	K3P-03AS/BS/CS	Version 2.2 or later	
	K80S	K7M Series	Version 1.6 or later	
PADT	GMWIN		Version 3.6 or later	
	KGLWIN		Version 3.3 or later	
Communication Master	Pnet	G3/4/6L-PUEA/B	Version 1.0 or later	

The following table indicates CPUs available to communicate with Pnet remote I/F module

Classification		Available master CPU list	Ref.	
CPU	GM3	GM3-CPUA		
	GM4	GM4-CPUA/B/C		
	GM6	GM6-CPUA/B/C		
	K1000S	K7P-30AS		
	K300S	K4P-15AS		
	K200S	K3P-03AS/BS/CS		
	XGK	XGL- CPUU/ CPUH/CPUS		
		XGL-CPUA/CPUE		
	XGI	XGI-CPUU/ CPUH/ CPUS/ CPUE		
	XGR	XGR-CPUH/T		Note1)
XGR-CPUH/F				

Note 1) In case of XGR system, master communication module can be installed on extension base.

1.5 Notice in Using

When installing this device, notice the followings for the reliability and safety.

Category	Classification	Contents
Temperature	Condition	<ul style="list-style-type: none"> • When installing this device, maintain the temperature between 0~55 °C • Do not exposure it to direct light.
	Measure	<ul style="list-style-type: none"> • When temperature is too high, install fan, air-conditioner and when temperature is too low, install suitable device.
Condensing	Condition	<ul style="list-style-type: none"> • No condensing allowed. • Install something in the control panel for protection from the water and dust.
	Measure	<ul style="list-style-type: none"> • Due to the frequent On/Off, condensing may occur. In this case, turn on the device at the night
Shock	Condition	<ul style="list-style-type: none"> • Install it in the place where impact and vibration don't occur..
	Measure	<ul style="list-style-type: none"> • When impact and vibration is severe, install anti-vibration rubber so that vibration and impact doesn't affect the device.
Gas	Condition	<ul style="list-style-type: none"> • Install in the place where there is not corrosive gas.
	Measure	<ul style="list-style-type: none"> • When corrosive gas enters, plan air-purification measure in the control panel.
EMC Environment	Condition	<ul style="list-style-type: none"> • Install in the place where electro-magnetic wave is not severe.
	Measure	<ul style="list-style-type: none"> • In case of wiring, set the precise route. • Check the shield of control panel <p>For light, use glow lamp and avoid fluorescent lamp</p> <ul style="list-style-type: none"> • When installing power module, ground the device at standard electric potential

Chapter 2 Product Specification

2.1 General Specification

The General Specification of Pnet I/F module is as follows.

No.	Items	Specifications	Related standards				
1	Ambient temperature	0 ~ 55 °C					
2	Storage temperature	-25 ~ +70 °C					
3	Ambient humidity	5 ~ 95%RH (Non-condensing)					
4	Storage humidity	5 ~ 95%RH (Non-condensing)					
5	Vibration resistance	Occasional vibration			-	10 times each directions (X, Y and Z)	IEC61131-2
		Frequency	Acceleration	Amplitude	times		
		$10 \leq f < 57\text{Hz}$	-	0.075mm			
		$57 \leq f \leq 150\text{Hz}$	$9.8\text{m/s}^2(1\text{G})$	-			
		Continuous vibration					
		Frequency	Acceleration	Amplitude			
		$10 \leq f < 57\text{Hz}$	-	0.035mm			
$57 \leq f \leq 150\text{Hz}$	$4.9\text{m/s}^2(0.5\text{G})$	-					
6	Shock resistance	<ul style="list-style-type: none"> • Peak acceleration: $147\text{m/s}^2(15\text{G})$ • Duration: 11ms • Half-sine, 3 times each direction per each axis 	IEC61131-2				
7	Noise resistance	Square wave impulse noise	$\pm 1,500\text{V}$	LSIS standard			
		Electrostatic discharge	4kV (Contact discharge)	IEC61131-2 IEC61000-4-2			
		Radiated electromagnetic field noise	80 ~ 1,000 MHz, 10V/m	IEC61131-2, IEC61000-4-3			
		Fast transient/burst noise	Segment	Power supply module	Digital/analog input/output communication interface	IEC61131-2 IEC61000-4-4	
Voltage	2kV		1kV				
8	Environment	Free from corrosive gasses and excessive dust					
9	Altitude	Up to 2,000 ms					
10	Pollution degree	2 or less					
11	Cooling	Air-cooling					

Note

1) IEC (International Electrotechnical Commission):

An international nongovernmental organization which promotes internationally cooperated standardization in electric/electronic field, publishes international standards and manages applicable estimation system related with.

2) Pollution degree:

An index indicating pollution degree of the operating environment which decides insulation performance of the devices. For instance, Pollution degree 2 indicates the state generally that only non-conductive pollution occurs. However, this state contains temporary conduction due to dew produced.

2.2 Communication Module Specification

2.2.1 Pnet remote I/F module specification

Item		Specification				
Standard		EN50170 / DIN 19245				
Interface		RS-485(electric)				
Media access		Polling				
Topology		Bus method				
Amplitude method		NRZ				
Communication interface		Auto baud rate				
Master/Slave		Slave				
Max. station count per network		100 stations (including master and repeater)				
Max. station count per segment		32 stations (including master and repeater)				
Cable		Twisted shielded cable				
Max. communication data size		TX/RX each 244 byte				
I/O parameter setting		After writing I/O parameter using expansion adapter, download through USB				
Communication speed and distance	Speed (kbps)	9.6	19.2	93.75	187.5	500
	Distance (m)	1200	1200	1200	1000	400
	Speed (kbps)	1500	3000	6000	12000	-
	Distance (m)	200	100	100	100	-
Max. node count		100 stations (setting range: 0 ~ 99)				
Max. expansion module installation count		12 modules				
Max. digital I/O points		768 points (Input max. 768 points/output max. 768 points, 64-point module x 12 slots)				
Max. analog I/O channels		Input max 122 channels (Max. TRX 244 byte/2) Output max 96 channels (8 channels X 12 slots) - 1 word per channel				
Internal consumption current (mA)		600				
Weight (g)		114				

Note

How to write the parameter of special module and I/O module through expansion adapter is same as that through XG5000. For more detail, refer to XG5000 and special module manual.

2.3 Communication Cable Specification

2.3.1 Profibus-DP cable specification

1) Cable specification

Classification	Contents	
Cable	▶ BELDEN cable:: Product name : 3077F, 3079A ▶ Tomas cable : Product name : Profibus-DP UNITRONIC-BUS L2/FIP/BUS	
AWG	22	
Type	BC (Bare copper)	
Insulation	PE (Polyethylene)	
Insulation intensity	0.035 (inch)	
Shield	Aluminum Foil-Polyester Tape /Braid Shield	
Capacity	8500pF/ft	
Characteristic impedance	150 Ω	
Core count.	2 Core	

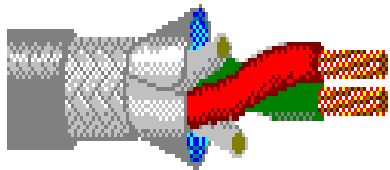

2) Connector's structure and connector wire method

- (1) Input wire: green line is connected to A1, red line is connected to B1.
- (2) Output wire: green line is connected to A2, red line is connected to B2
- (3) Shield is connected to connector's clamp.
- (4) When installing the connector in terminal, install cable at the A1.B1.

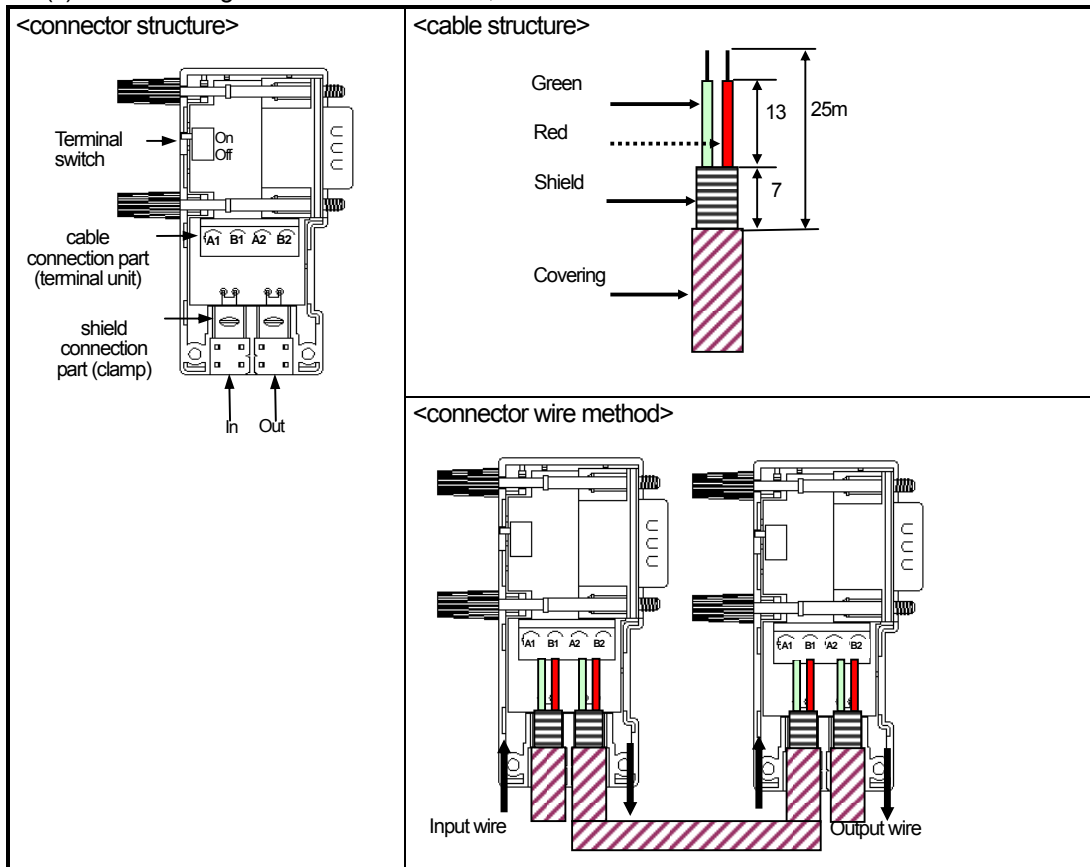

2.4 Terminating

2.4.1 Pnet Terminating

- Connection Connector

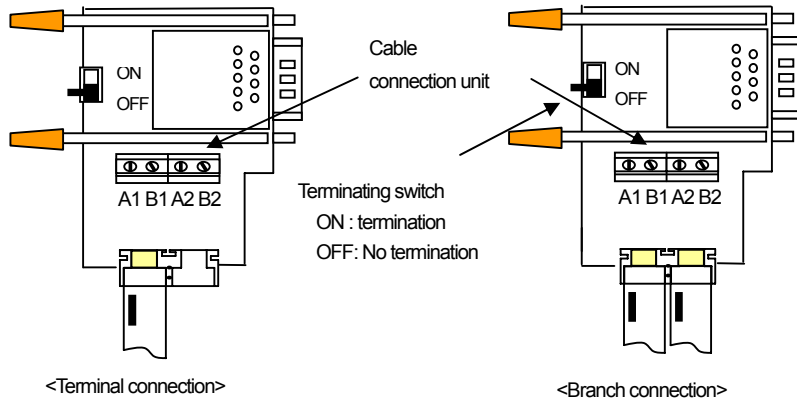

Chapter 3 System Configuration

This chapter describes the method of system configuration and characteristics.

3.1 Notices in Selecting Module

Here describes the notices in selecting digital I/O module which is used for Remote I/O.

1) Digital input types contain the current sink input and current source input. In case of DC input module, as the wiring method of external input power is different according to such input types, make sure of selecting the input module considering the spec. of input connection machine. The wiring method per type is as follows.

(1) How to connect the sink type external connection machine to the source type DC input module.

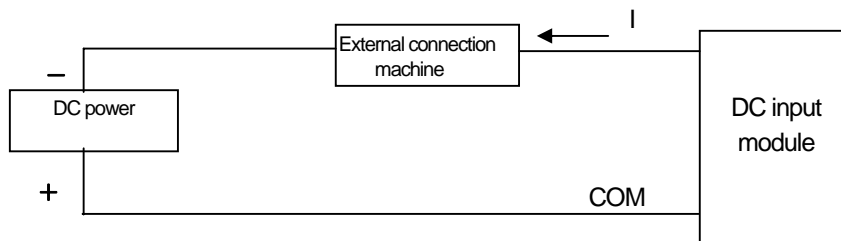

- External connection machine is located between DC power and (-) terminal of DC input module terminal.
- Thus, when inputting ON, the current flows from DC input module terminal to external connection machine.

(2) How to connect the source type external connection machine to the sink type DC input module.

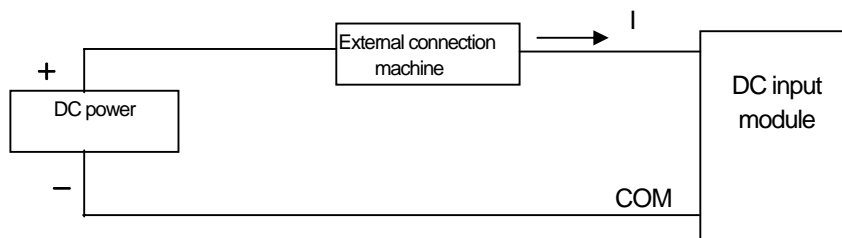

- External connection machine is located between DC power and (+) terminal of DC input module terminal.
- Thus, when inputting ON, the current flows from external connection machine to DC input module terminal.

2) In case that the open/close frequency is high or it is used to open/close the conductive load, please use transistor output module as Relay output module may reduce the life.

3.2 Names of Each Part

3.2.1 Basic System Configuration

Communicates with master and controls expansion I/O module through Backplane Bus

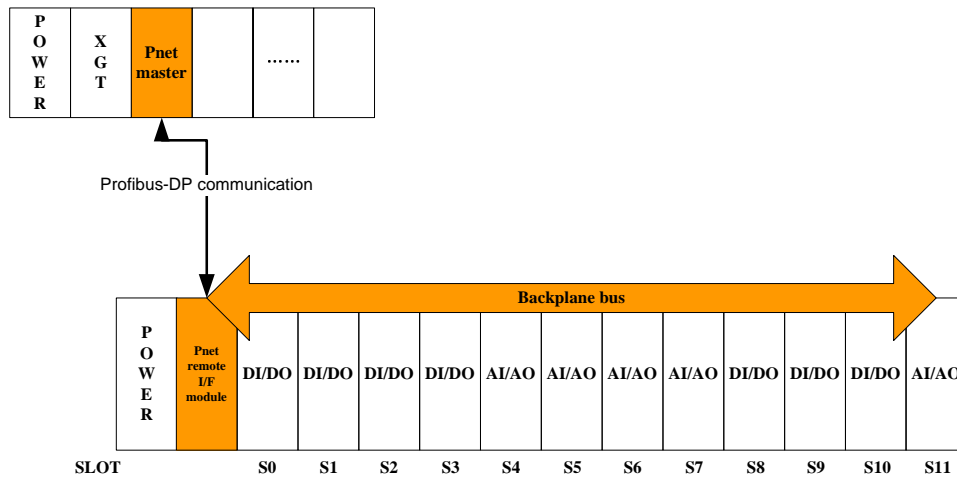

3.2.2 Names and Functions of Each Part

1) Pnet remote I/F module

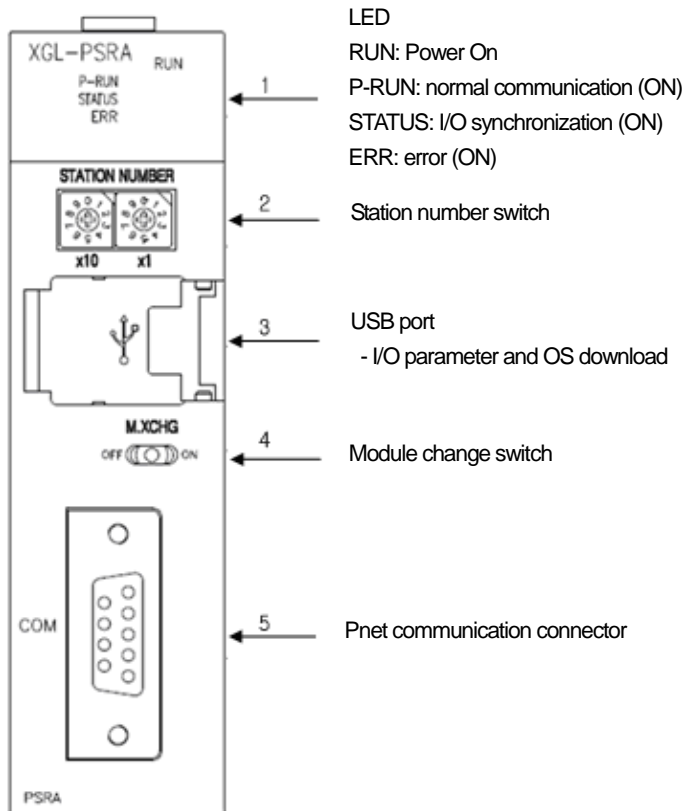

2) LED

Item	Name	Normal	Abnormal	LED indication contents
1	RUN	On	-	Module normal (Normal operation of system O/S)
		-	Off	O/S is not operating (O/S operation error by H/W error)
2	P-RUN	On	-	Pnet communication normal
		-	Off	Not connected with master or not communicating with master
3	STATUS	On	-	System configuration of master is same as I/O configuration of slave so communication is normal
		-	Off	System configuration of master is not same as I/O configuration of slave so communication is not normal
4	ERR	-	On	Error → refer to the following error type
		Off	-	No error

3) Error type

(1) Module detachment error

Module is detached from base while M.XCHG switch is off

(2) Invalid module is attached

Invalid module such as communication module, High Speed Counter module, etc is attached at Base

(3) Out of I/O points

I/O module configuration exceeding max. I/O data size (244 byte) or no I/O data

(4) I/O parameter error

I/O parameter set by user is different with actual I/O configuration

- When different parameter is downloaded during communication: ERR LED Off

- When different parameter is downloaded during not communicating: ERR LED On

3.2.3 Available Product List

1) Power module list

Model	Specification
XGP-ACF1	AC100V - AC240V, 3A
XGP-ACF2	AC100V - AC240V, 6A
XGP-AC23	AC200V - AC240V, 8.5A
XGP-DC42	DC24V, 6A

2) Base list

Model	Specification	Remark
XGB-M04A	4-slot main base	※ Up to 12 slots are available and expansion base through expansion cable is not supported
XGB-M06A	6-slot main base	
XGB-M08A	8-slot main base	
XGB-M12A	12-slot main base	

3) Digital I/O module list

Input module	XGI-A12A	AC110V, 16 point
	XGI-A21A	AC220V, 8 point
	XGI-D21A	DC24V, 8 point
	XGI-D22A	DC24V, 16 point, sink/source
	XGI-D22B	DC24V, 16 point, sink
	XGI-D24A	DC24V, 32 point, sink/source
	XGI-D24B	DC24V, 32 point, sink
	XGI-D28A	DC24V, 64 point, sink/source
	XGI-D28B	DC24V, 64 point, sink
Output module	XGQ-RY1A	Relay, 8 point
	XGQ-RY2A	Relay, 16 point
	XGQ-RY2B	Relay, 16 point, Built-in surge killer
	XGQ-SS2A	Triac, 16 point
	XGQ-TR2A	TR, 16 point, sink
	XGQ-TR2B	TR, 16 point, source
	XGQ-TR4A	TR, 32 point, sink
	XGQ-TR4B	TR, 32 point, source
	XGQ-TR8A	TR, 64 point, sink
	XGQ-TR8B	TR, 64 point, source
I/O module	XGH-DT4A	DC24V, 16 point input / TR 16 point, sink

Note

For specification of I/O module, refer to XGI or XGK CPU manual.

Chapter 3 System Configuration

4) Analog module list

Analog input	XGF-AV4A	• Voltage input: 4 channels
	XGF-AV8A	• Voltage input: 8 channels
	XGF-AC4A	• Current input: 4 channels
	XGF-AC8A	• Current input: 8 channels
	XGF-AD8A	• Voltage/current input: 8 channels
	XGF-AD4S	• Voltage/current input: 4 channels, insulation between channels
	XGF-AW4S	• Voltage/current input: 4 channels(2-wire input), insulation between channels
	XGF-AD16A	• Voltage/current input: 16 channels
Analog output	XGF-DV4A	Voltage output type, 4 channels
	XGF-DC4A	Current output type, 4 channels
	XGF-DV8A	Voltage output type, 8 channels
	XGF-DC8A	Current output type, 8 channels
	XGF-DV4S	Voltage output type, 4 channels, insulation type
	XGF-DC4S	Current output type, 4 channels, insulation type
Temp. conversion	XGF-TC4S	Thermocouple input, 4 channels, insulation type
	XGF-RD4A	RTD input, 4 channels
	XGF-RD4S	RTD input, 4 channels, insulation type
Analog I/O	XGF-AH6A	Voltage/current selection input type, 4 channels / voltage/current selection output type, 2 channels - 4 words are allocated for each I/O in XGL-PSRA.

Note

For specification of analog I/O module, refer to each product's user manual.

3.3 System Configuration Example

3.3.1 Pnet System (GMWIN)

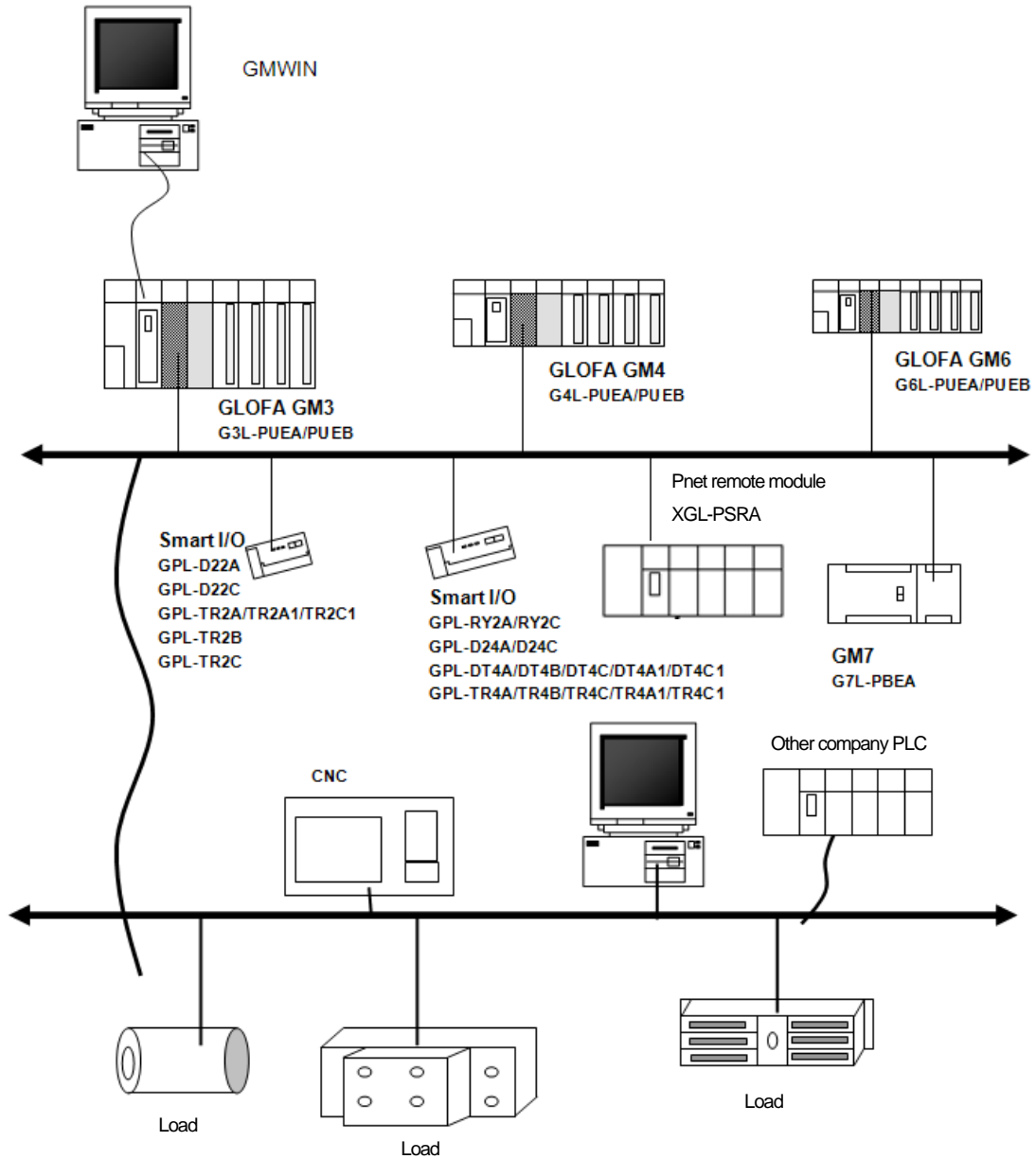

3.3.2 Pnet system (XG5000)

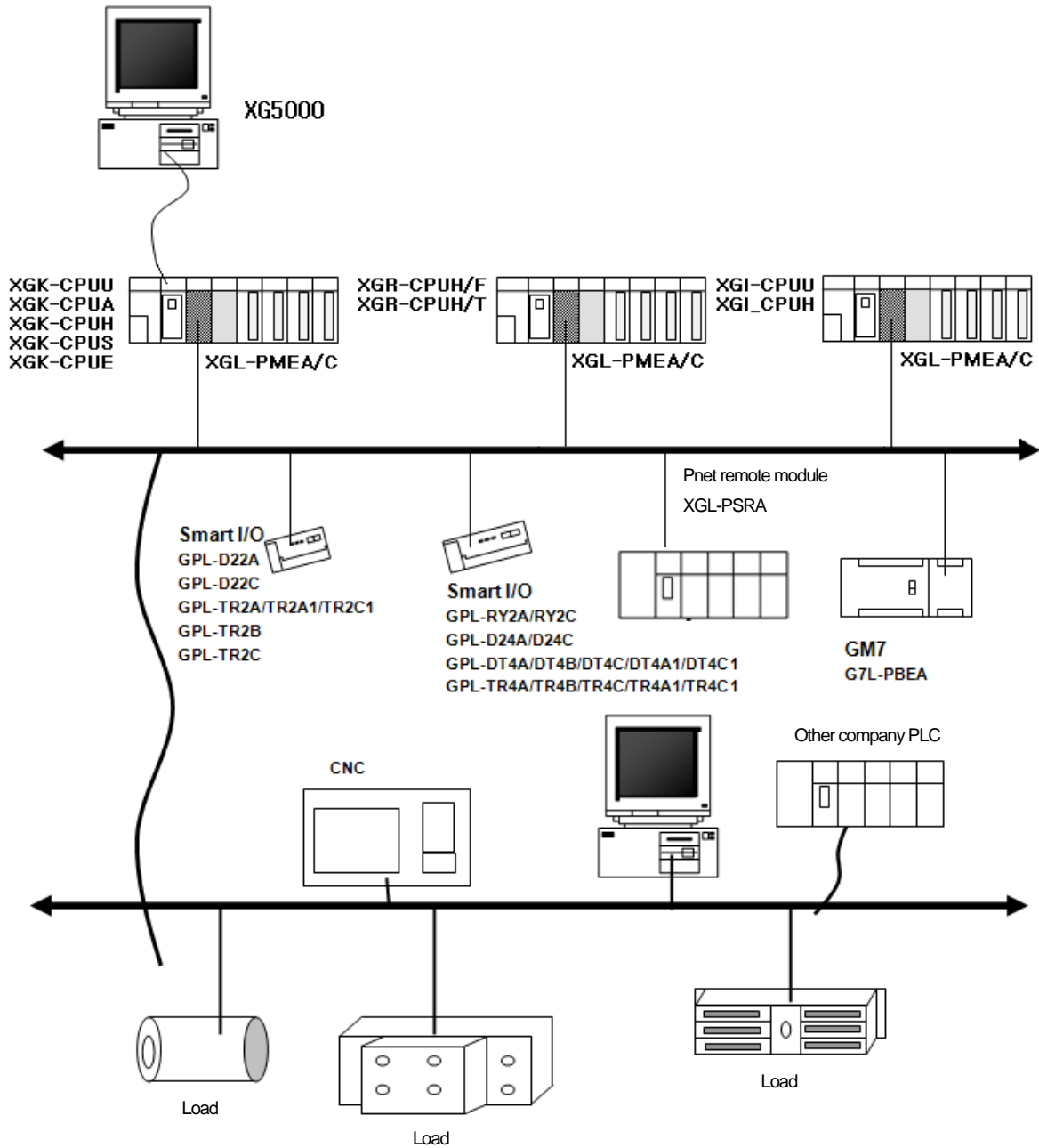

Chapter 4 Communication Programming

4.1 How to Set Master Module

Describes how to set master module to use Pnet remote module
 For more detail, refer to master module's user manual.

4.1.1 High-speed Link

High-speed Link is used when other station's data or information is periodically exchanged at every specific time. By referring to the changing data of its own station or other station periodically, it enables to utilize the data to the system effectively and communicates by setting the simple parameter.

The setting method is to designate its own area and the area of other station, data size, and station no. (for GLOFA series, in GMWIN, for MASTER-K, in KGLWIN, for XGT, in XG-PD) and then carry out communication. Data size is from minimum 1 byte (8 point) to 244 byte. And communication period is from maximum 10ms to 10s according to communication contents

As it is available to communicate with other station by simple parameter setting, it is easy to use this program and the High-speed process of internal data enables to process lots of data at the same time periodically

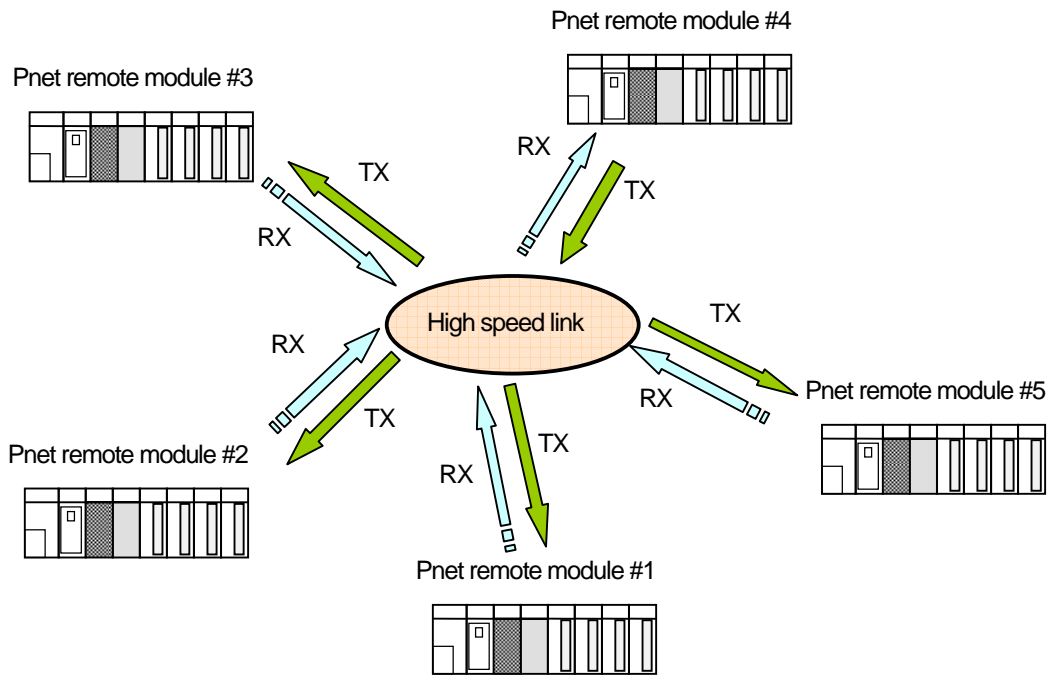

4.1.2 XG-PD's Link Parameter Setting

When using XGT Pnet master module, it is easy to set device region and data size to communicate between CPU module and Communication module (Master module and Slave module) by using XG-PD.

1) Pnet High-speed Link setting Contents

Contents		High-speed Link			
Communication module setting	Communication module setting	Module Type	Select Pnet		
		Base No.	Max: 0 ~ 7, Setting range differ according to CPU module.		
		Slot No.	Max: 0 ~ 11, Setting range differ according to base Type.		
	Communication period setting (Period Type)	Select among 10ms, 20ms, 50ms, 100ms, 200ms, 500ms, 1s, 5s, 10s -default is 10ms.			
	Output data setting when emergency	CPU Error	Latch	Maintain previous output status.	
			Clear	Clear all output.	
		CPU Stop	Latch	Maintain previous output status.	
			Clear	Clear all output.	
	Mode	Sending: transfers data from Master module to Slave module. Receiving: transfers data from Slave module to Master module.			
	Station No.	Slave Station No. (Range: 1 ~ 99)			
	Communication type	Indicate communication type between Master and Slave. (Poll, Bit-Strobe, COS, Cyclic)			
	Read area (Master module → Slave module)	Address	first device of TX devices Available device: P, M, K, F, T, C, U, Z, L, N, D, R, ZR		
		Size (Byte)	Indicate I/O point into Byte. - Consider less than 8 bit I/O module as 1 Byte		
	Save area (Slave module → Master module)	Address	first device of RX devices Available device: P, M, K, F, T, C, U, Z, L, N, D, R, ZR		
Size (Byte)		Indicate Slave module's I/O point into Byte. - Consider less than 8 bit I/O module as 1 Byte			
PLC connection	CPU module's RS-232C or USB port				
Control condition	Control is available regardless of location (RUN, STOP) of mode switch of CPU module.				
Max. communication point	TX 28,672 point, RX 28,672 point each 3584 byte				
Max. Block No.	126 (0~125)				
Max. point per block	244				
High-speed link setting count	Max. 12				

Notice

- 1) The above category is not set in XG-PD.
 - 2) This data is uploaded value from XG-PF which is set in SyCon.
 - 3) Set according to the following sequence.
 - First: Set parameter by SyCon → download
 - Second: XG-PD → I/O Information Reading → SyCon Upload → High-speed Link parameter setting → parameter download → Enable High-speed Link
 - If you don't follow above sequence, it may cause change of setting value.
 - ▶ When you change High-speed Link contents, you should download parameter again.
 - ▶ It is available to set and use only one High-speed Link per one communication module.
 - ▶ Written parameter (basic, High-speed Link, P2P) is stored in CPU module.
- When changing CPU module, download backup parameter set in XG-PD and write it to new CPU module.
For description on SyCon, refer to chapter 5

1) How to use XG-PD

How to use XG-PD for Pnet I/F Module is as follows.

Execute XG-PD

(a) Read I/O Information

Read information of Pnet I/F module

The screenshot shows the 'Connect' menu in the XG-PD software. The 'Read IO Information' option is highlighted in blue. Other visible options include 'Write Parameter (Standard Settings, HS Link, P2P)', 'Read Parameter (Standard Settings, HS Link, P2P)', 'Delete Parameter (Standard Settings, HS Link, P2P)', 'Enable Link (HS Link, P2P)', 'Upload/Download (File)', 'Sycon Upload (Dnet, Pnet)', 'System Diagnosis', and 'Reset'. There is an 'or' icon and a small device icon to the right of the menu.

(b) High-speed Link Setting

- 1) Communication module setting
 - a) Communication module setting: Pnet
 - Type of module, Base, Slot
 - b) Communication period setting
 - c) Data setting when emergency.
 - CPU module error, CPU module stop
- 2) Block setting
 - Online → SyCon Upload
 - Read area/Save area setting

- 1) Connect Pnet I/F module read from I/O information with High-speed Link.
- 2) Read system information set by SyCon.
- 3) Designate device and address used in program to connect I/O point about the slave module which is composed in SyCon with PLC program.

(c) Write Parameter

Write High-speed Link parameter to Pnet I/O Module

The screenshot shows the 'Connect' menu in the XG-PD software. The 'Write Parameter (Standard Settings, HS Link, P2P)' option is highlighted in blue. Other visible options include 'Read IO Information', 'Read Parameter (Standard Settings, HS Link, P2P)', 'Delete Parameter (Standard Settings, HS Link, P2P)', 'Enable Link (HS Link, P2P)', 'Upload/Download (File)', 'Sycon Upload (Dnet, Pnet)', 'System Diagnosis', and 'Reset'. There is an 'or' icon and a small device icon to the right of the menu.

(d) Enable Link

Enable Pnet I/F module's communication.

The screenshot shows the 'Connect' menu in the XG-PD software. The 'Enable Link (HS Link, P2P)' option is highlighted in blue. Other visible options include 'Read IO Information', 'Write Parameter (Standard Settings, HS Link, P2P)', 'Read Parameter (Standard Settings, HS Link, P2P)', 'Delete Parameter (Standard Settings, HS Link, P2P)', 'Upload/Download (File)', 'Sycon Upload (Dnet, Pnet)', 'System Diagnosis', and 'Reset'. There is an 'or' icon and a small device icon to the right of the menu.

4.1.3 High-speed Link communication status flag information (XGT)

Communication Flag List corresponding to High-speed Link Number High-speed Link No.1~12.

No.	Keyword	Type	Contents	Contents Explanation
L000000	_HS1_RLINK	Bit	All stations of High-speed Link No.1 are normal.	It indicates normal status of all stations which operate according to parameter set in the High-speed Link. If the following condition is met, It would be turned On. 1. All stations set in parameter are RUN mode and there is no Error. 2. All data blocks set in parameter operate properly. 3. When parameter of each station in parameter communicates normally, after Run_Link is On, Run_Link maintains On continuously unless quitted by disable.
L000001	_HS1_LTRBL	Bit	Indicates abnormal After _HS1RLINK ON	When _HSmRLINK Flag is On, if station set in parameter and communication status is same as the followings, this flag is turned On. 1. Station set in parameter is not RUN mode. 2. Station set in parameter has Error. 3. Communication status of data block set in parameter is not proper. If above condition is met, Link_Trouble set On. If condition is normal, Link_Trouble set Off.
L000020 ~ L00009F	_HS1_STATE[k] (k=000~127)	Bit Array	Indicates High-speed Parameter No.1 Kth Block's total status	It indicates total status about each data block set in parameter. HS1STATE[k]=HS1MOD[k]&_HS1TRX[k]&(~_HSmERR[k])
L000100 ~ L00017F	_HS1_MOD[k] (k=000~127)	Bit Array	Run Mode of High-speed Parameter No.1 Kth Block	It indicates operation mode of station set in Kth block of parameter.
L000180 ~ L00025F	_HS1_TRX[k] (k=000~127)	Bit Array	Indicates normal Communication status with High-speed Parameter No.1 Kth Block	It indicates whether communication status of parameter's Kth data block operates normally or not according to setting.
L000260 ~ L00033F	_HS1_ERR[k] (k=000~127)	Bit Array	Error Mode of High-speed Parameter No.1 Kth Block	It indicates whether communication status of parameter's Kth data block has error or not.
L000340 ~ L00041F	_HS1_SETBLO CK[k]	Bit Array	Indicates setting of High-speed Parameter No.1 Kth Block	It indicates whether Kth data block of parameter is set or not.

* In case of Pnet, Kth block indicates slave's station number.

Note

High-speed Link Number	L Region Address Number	Reference
2	L000500~L00099F	When [Table 1]'s High-speed Link is 1, other Flag address number is as follows according to simple calculation. *Calculation: L region address number = L000000 + 500 X (High-speed Link Number-1) In the case of using the High-speed Link Flag for the program and monitoring, use Flag Map registered in the XG5000.
3	L001000~L00149F	
4	L001500~L00199F	
5	L002000~L00249F	
6	L002500~L00299F	
7	L003000~L00349F	
8	L003500~L00399F	
9	L004000~L00449F	
10	L004500~L00499F	
11	L005000~L00549F	

K indicates information about 128 Blocks from Block No.000 to 127 through 8 word (Each word consist of 16 block.). For example, mode information (_HS1MOD) has information about block 0 ~15 in the L00010. (16~31, 32~47, 48~63, 64~79, 80~95, 96~111, 112~127 in the L00011, L00012, L00013, L00014, L00015, L00016, L00017) So block no. 55's mode information in the L000137

4.2 How to register XGT Profibus-DP remote module

In order to use XGT Profibus-DP remote module, you have to register an extended module parameter by using Extended Adapter.

4.2.1 Create new project

Select "File – New File" and then select "XGL-PSRA" at Adapter type.

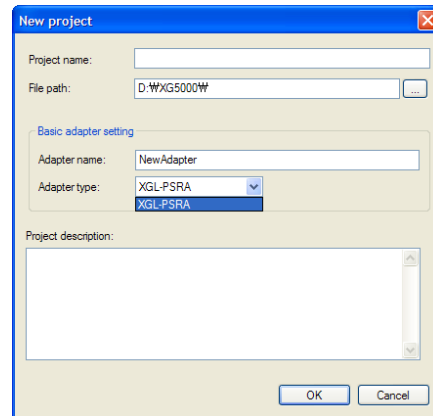
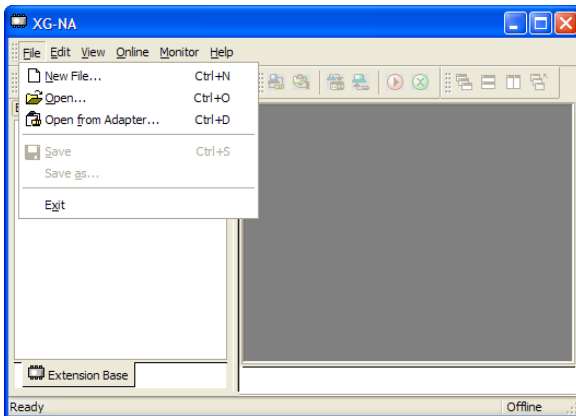

After connecting USB cable to XGT Profibus-DP remote module, turn on the power. Select "Online – Connection Settings" and then set the "Type" as USB and "Depth" as local. Then establish connection.

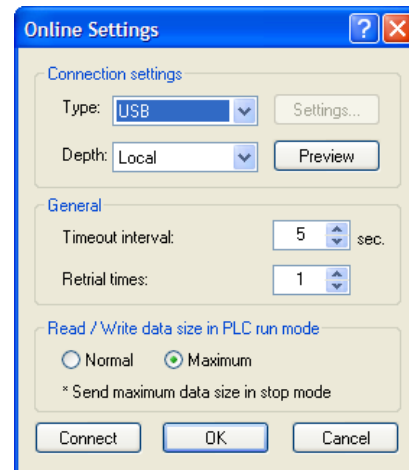
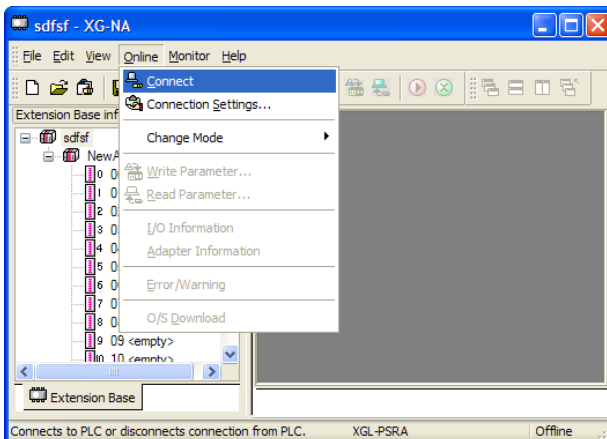

4.2.2 Set IO parameter

If I/O parameter is different with actual system configuration in main base, XGT Profibus-DP remote module indicates “Module type mismatch” error. At this time, STATUS LED is off.

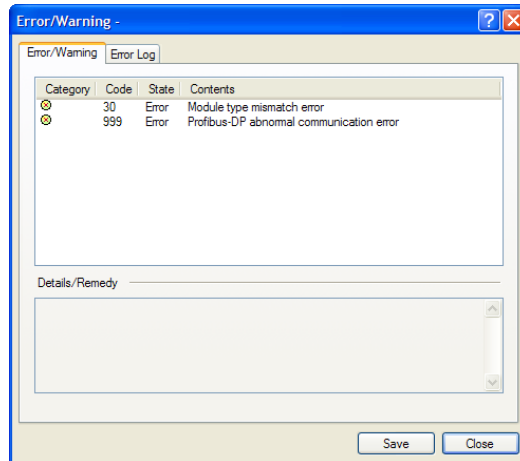

1) I/O synchronization

Open “I/O information” at “Online” and check whether I/O information matches actual system configuration.

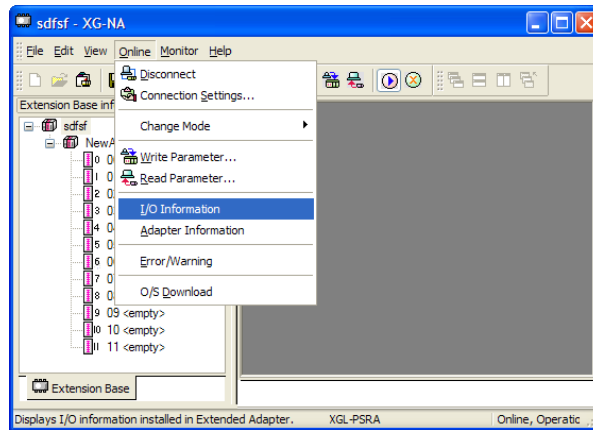

The following figure is I/O information where TR output modules are in slot 0 and 1, XGF-DV8A in slot 2, XGF-AD4S in slot 3.

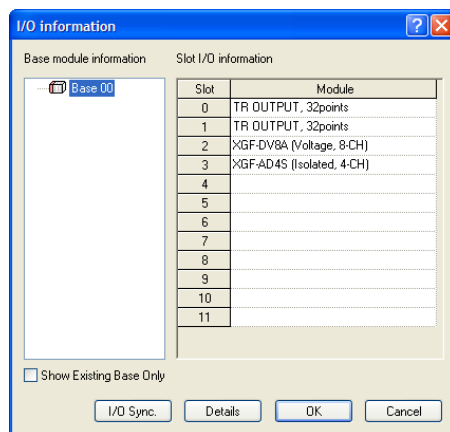

Chapter 4 Communication Programming

If I/O information matches actual module configuration, click “I/O synchronization button” and match I/O information.

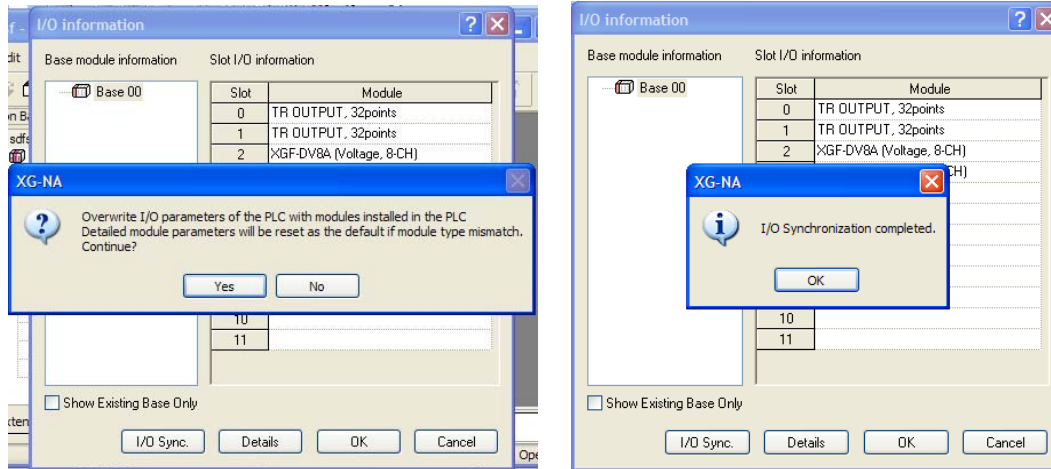

If “module mismatch error” appears, check whether ERR LED is off or not.
Check whether all modules are registered at project window.

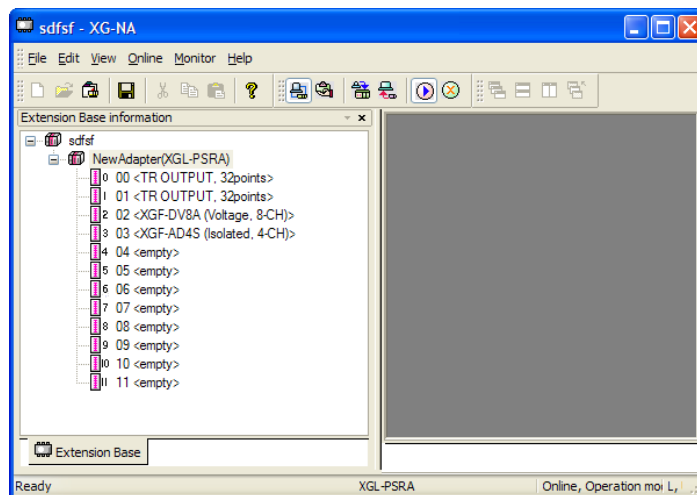

1) Analog module parameter setting

To set a detail parameter on the module, double-click the module at project window.

The figure below is parameter window when you double-click the XGF-DV8A.

For detail on the each parameter, refer to the product’s manual.

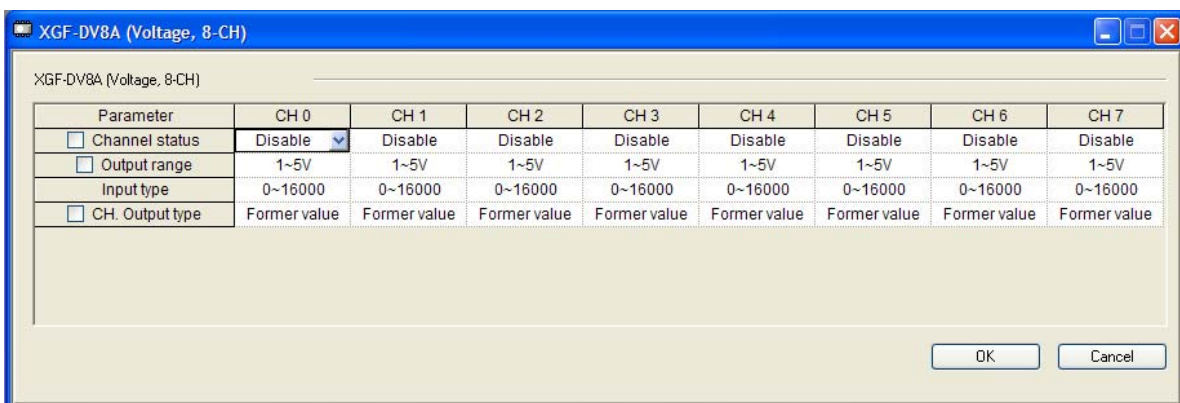

After completing the parameter setting, download the parameter through “Online → Write Parameter”.

2) Digital I/O module parameter setting

If you double-click the digital I/O module, for output module, emergency output setting window appears and for input module, input filter setting window appears as follows. Emergency output sets output status in case of remote module error. If emergency output is "Clear", output becomes '0' in case of error. If emergency output is "Hold", output holds last output data.

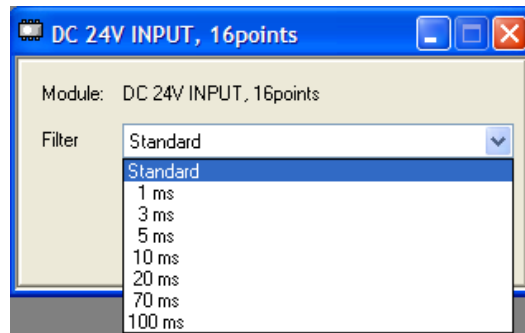
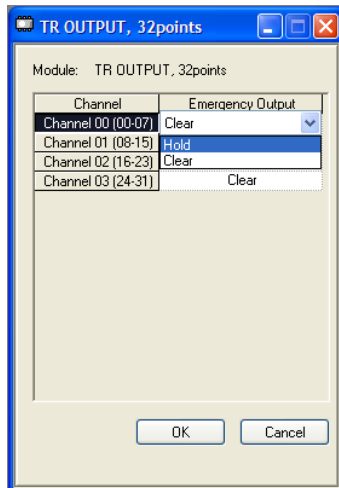

3) Save setting

Before downloading, save the project.

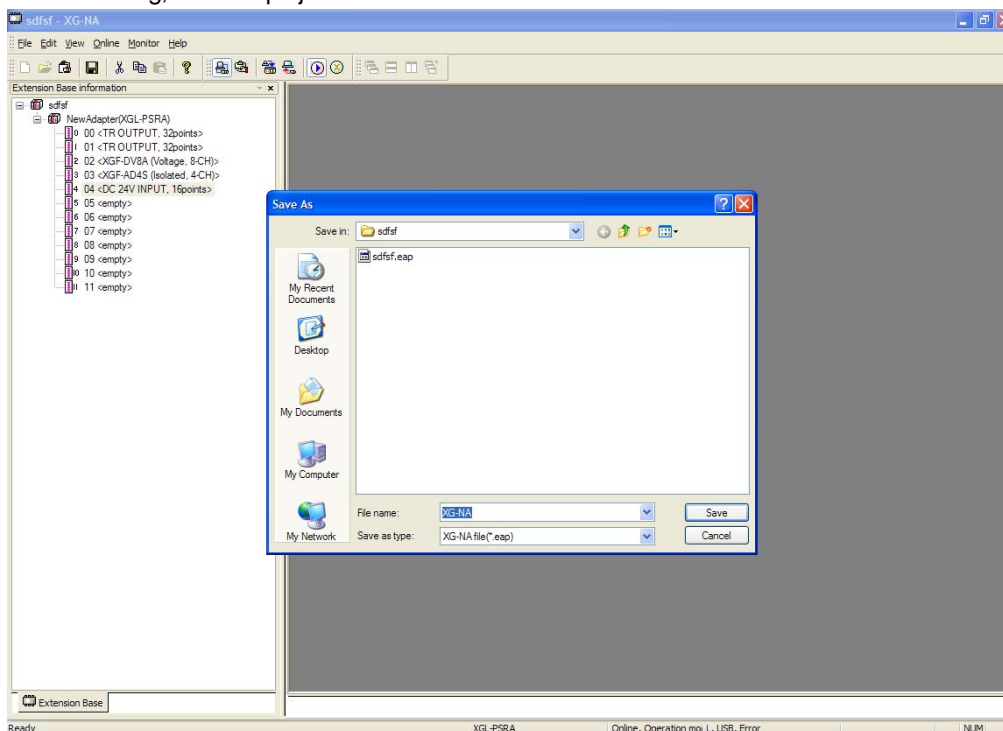

Chapter 4 Communication Programming

4) Write parameter

After completing the parameter setting, download parameter through “Online – Write Parameter”. If downloading is complete, complete message appears.

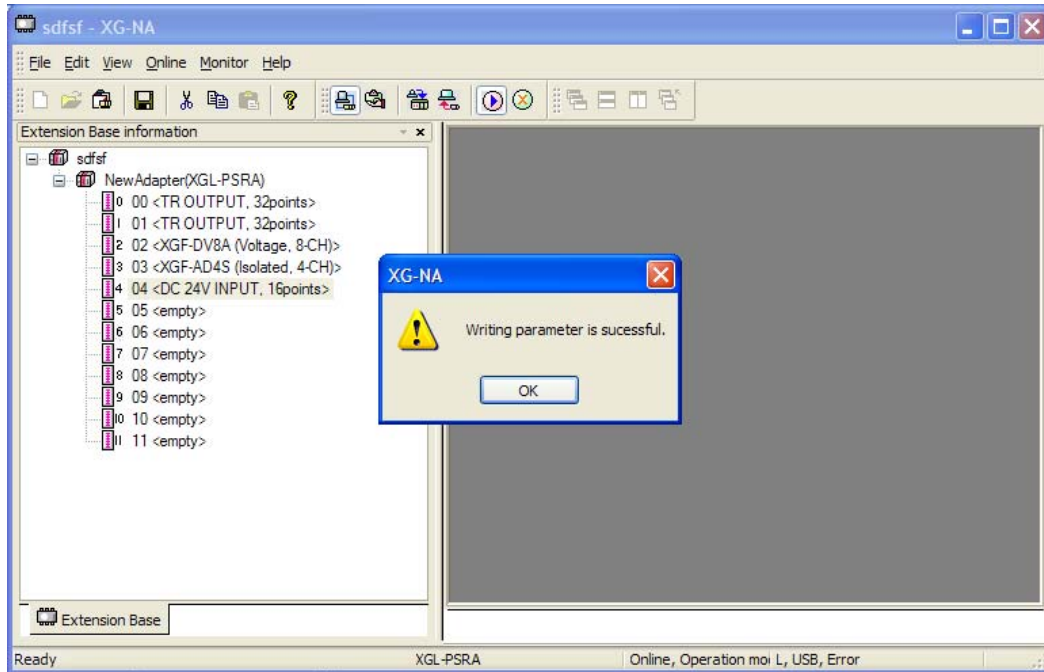

Note

- 1) Parameter is saved in flash memory permanently.
- 2) Emergency parameter is applied when communication with master is not normal.
- 3) Emergency output data is not maintained when power is off. If you turn off and on power while Emergency output is set as “Hold” and error occurs, emergency output data is not hold.
- 4) If you download parameter, read I/O, synchronize I/O during communication, communication may stop during some ms.

Chapter 5 Profibus-DP Communication

5.1 Overview

Profibus is an open type field bus that the manufacturer selects independently to apply and manufacture (Vendor-independence). Also, It is used widely for processing automation. DP among them is the most frequently used Communication profile and the network suitable for FA environment of Field Level and also is suitable for master-slave communication between master automation machine and distribution slave I/O machine. It is designed to install with low cost and is the most suitable item to replace the existing system such as 4~20mA or Hart system together with 24V parallel signal transmission to the production automation system.

For further information for Profibus-DP, please refer to 'Korea Profibus Association's homepage'. (<http://www.profibus.co.kr>)

5.2 Communication Specification

Classification	Profibus-DP	
Module type	Pnet remote I/F module	
Network type	Profibus-DP	
Slave protocol	DP-V0	
Standard	EN 50170 / DIN 19245	
Media access	Logical Token Ring	
Communication method	RS-485 (Electric)	
Topology	Bus	
Modulation method	NRZ (Non Return to Zero)	
MAX (media access method)	Local token ring	
Communication distance and transfer speed	Distance (m)	Transfer speed (bps)
	1,200	9.6k/19.2k/93.7k/187.5k
	400	500k
	200	1.5M
	100	3M/6M/12M
Max. Node/network	126 Stations	
Max. Node/segment	32 Stations	
Cable	Electric twisted shielded pair cable	
Max. I/O data/slave	244 byte	
Max. I/O module installation count	12	
Installation position	CPU slot	

5.3 Basic Performance

5.3.1 Overview

Profibus-DP Master module is available to set as the following function.

- (1) Supports only *High-speed Link* communication.
 - (2) Uses parameter setting in GMWIN/KGLWIN/XG-PD and Configuration Tool (LSIS provided tool : SyCon).
 - (3) Sets only sending/receiving area from GMWIN/KGLWIN/XG-PD high-speed link parameter setting.
 - (4) Sending/receiving data shall be saved continuously from the setting area and sent. (this is similar to the continued MAP of MASTER-K.)
 - (5) Uses SyCon to set sending/receiving number and slave area per slave station and uses Configuration Port to download as master module.
 - (6) Sending/receiving number is available up to 512bytes/3,584bytes respectively according to the type of Daughter board.
 - (7) Sending/receiving number per slave station is set as byte unit. (set in SyCon)
- Communication begins through GMWIN/KGLWIN/XG-PD *High-speed Link* enable set.

5.3.2 Operation by *High-speed Link*

- (1) If Master module is the product of LSIS (G3/4/6L-PUEA/PUEB, XGL-PMEA), it configures Profibus Network using SyCon.
- (2) Download Profibus Network Configuration to master module.
- (3) Set *High-speed Link* parameter of master in GMWIN and download it.
- (4) Enable *High-speed Link*.
- (5) If using other maker's product as Master, configure Profibus Network using Configuration Tool of the corresponding product.

5.3.3 Procedure to establish Pnet communication

Master communicates Pnet expansion I/O module based on the downloaded setting information

- 1) After writing parameter and checking, I/O data communication starts.
- 2) If it fails when processing each step, diagnosis is executed.
- 3) Initial sequence operation to establish communication is as follows.

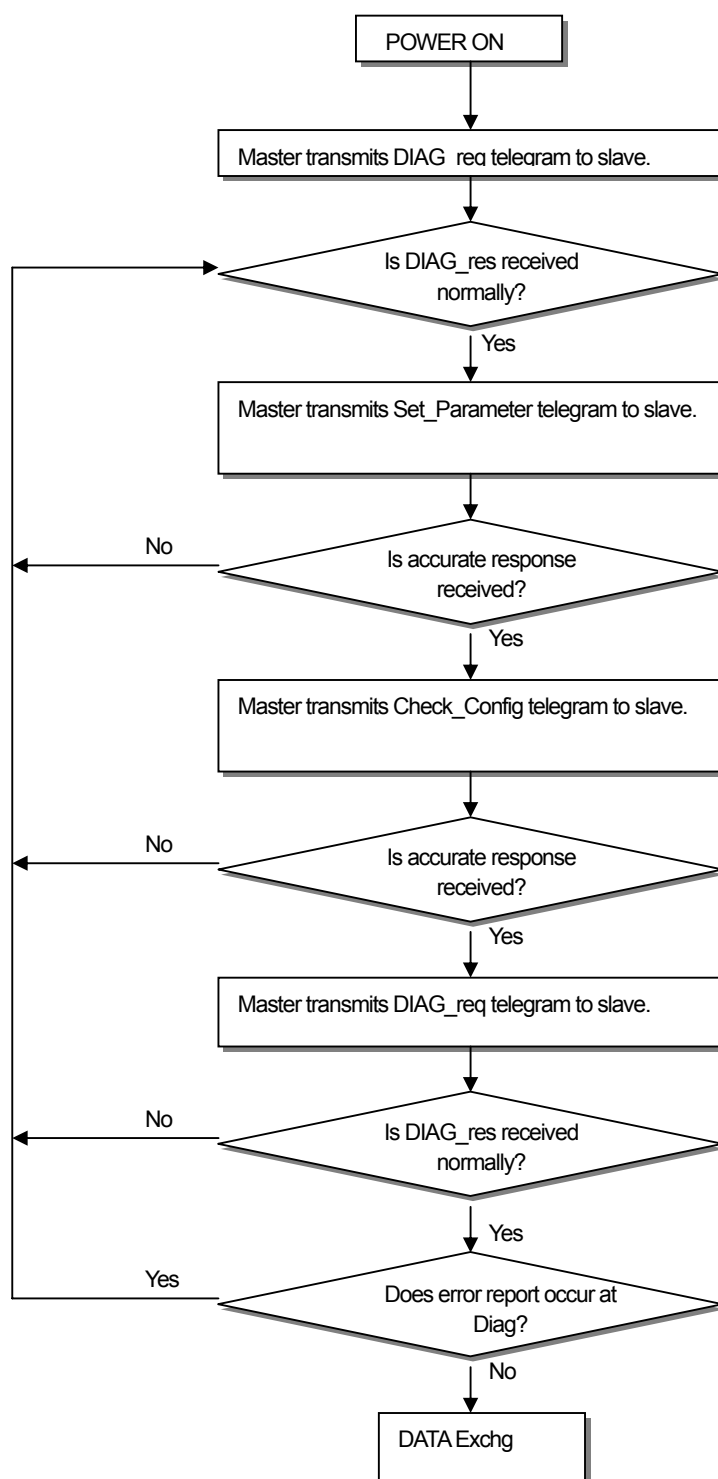

5.3.4 I/O Data Communication

- 1) Expansion I/O modules are communicates with master by using backplane bus.
- 2) Max. TRX data is 244 byte.

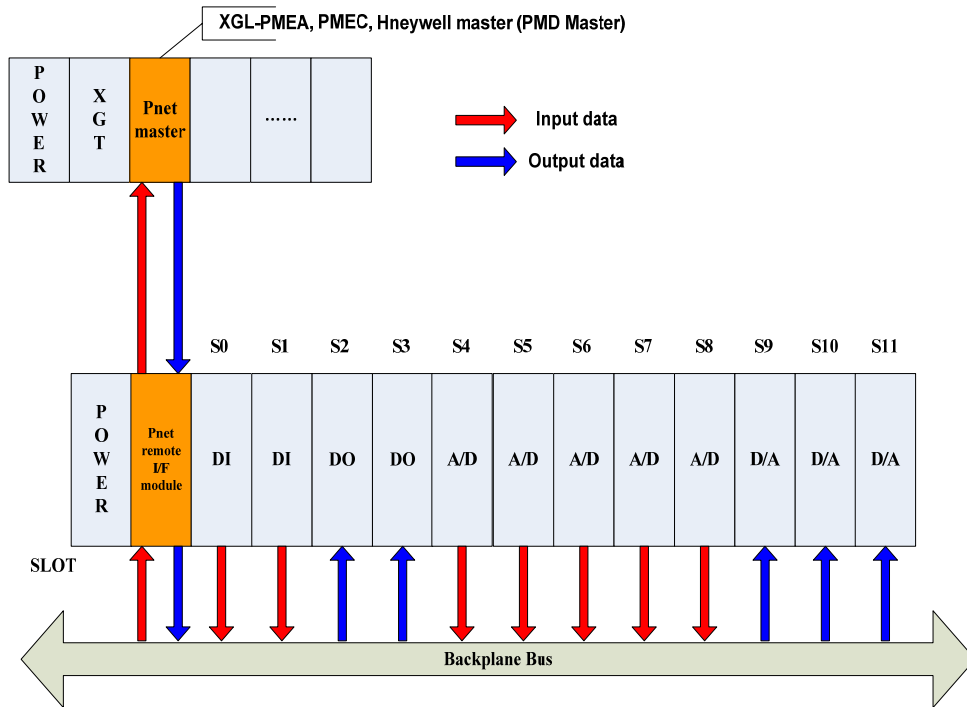

- 3) Writing parameter of expansion I/O module is available through local USB connection.

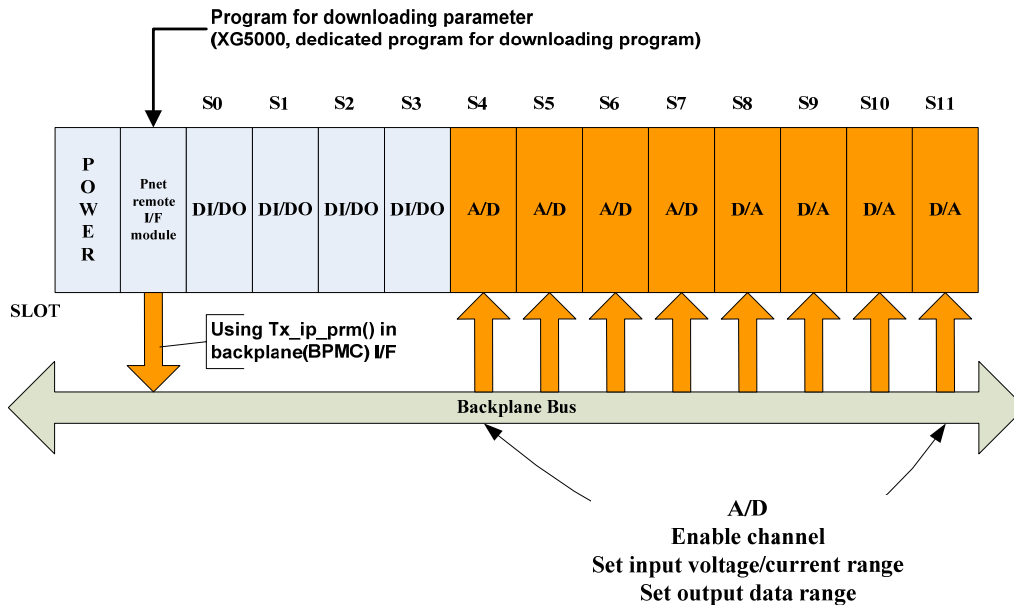

5.4 Tool for Communication Setting

5.4.1 Communication Setting by SyCon

If using master module provided by LSIS (G3/4/6L-PUEA/PUEB,XGL-PMEA), it is required to configure Profibus Network using SyCon and download the information to the corresponding master module. As Profibus Network Configuration Tool is different from each master module, if using LSIS master module (G3/4/6L-PUEA/PUEB,XGL-PMEA), it is required to use only SyCon.

1) SyCon execution

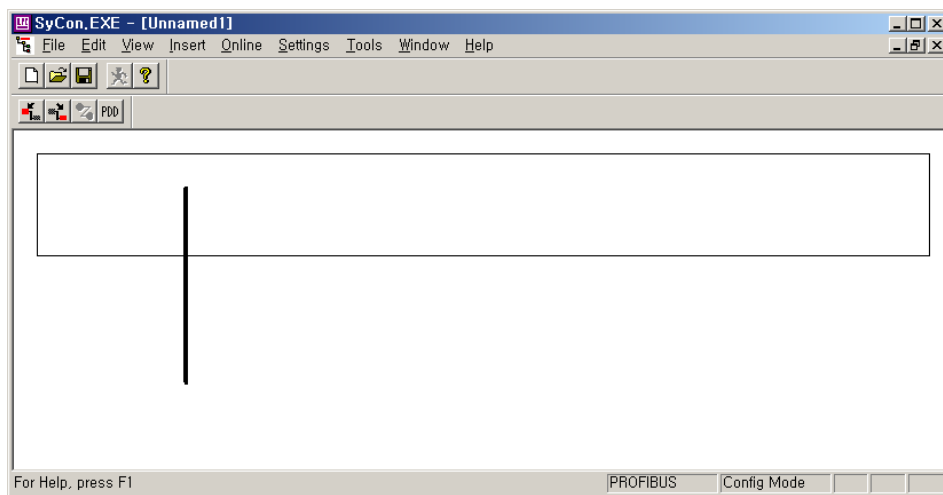

If there is no project using before executing SyCon, the initial screen same as the above figure will appear and if you are preparing the project, the latest project will be open.

2) Insertion of Master Module

Click "Insert → Master" or select  from the left top tool bar and click the proper point of left top from the window below.

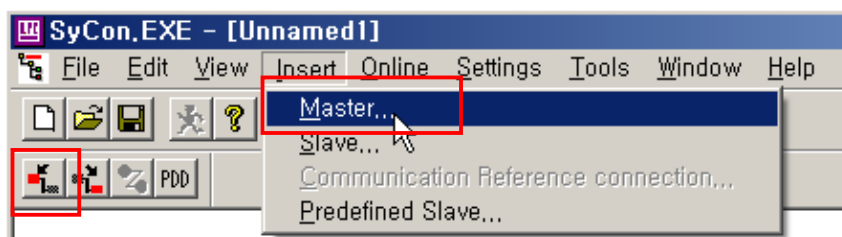

Chapter 5 Profibus-DP Communication

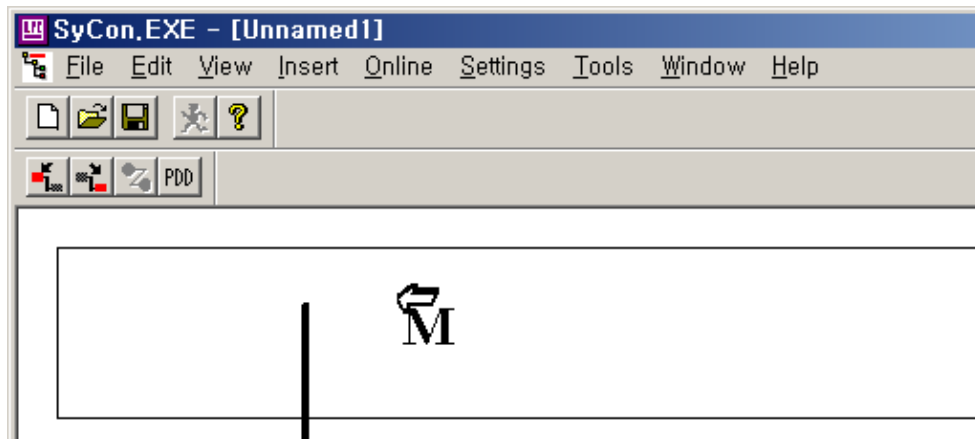

Insert the master at the top of window below

If Insert Master window is open as the above figure, select **COM-DPM/PKV20-DPM** if the using master module is **G3/4/6L-PUEA** and click Add button in the middle. If using master module is **G3/4/6L-PUEB**, select **COM-PB/PKV20-PB** and click Add button in the middle. If using master module is **XGL-PMEA**, select **COM-C-DPM** and click Add button in the middle part. Confirm Station address and if necessary, it is available to change Description. If pressing OK button, master module shall be inserted.

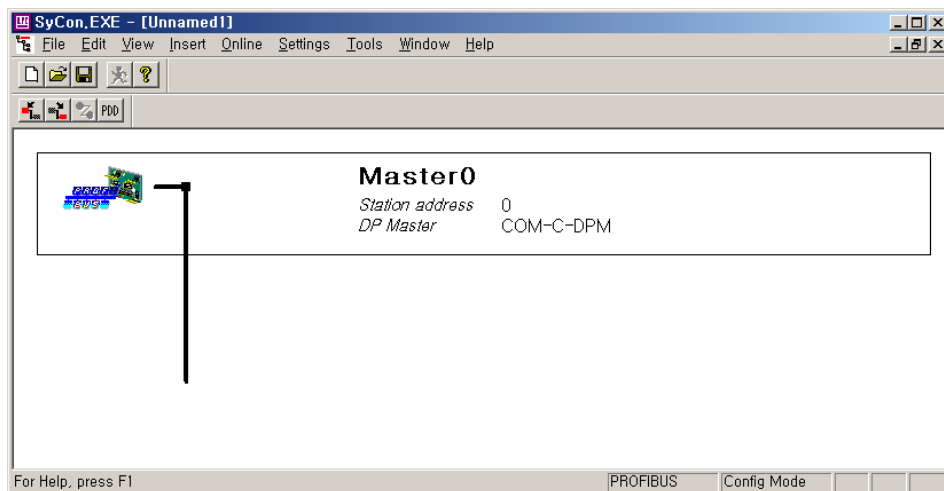
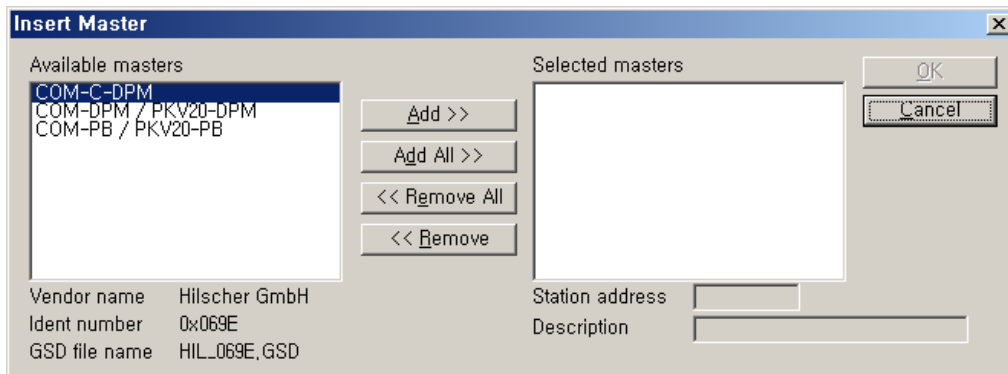

3) Master module setting

If you click the right side of mouse on the inserted master module and select “Master Settings...” from the appeared popup window, the following window will be open. Select “Controlled release of the communication by the application program” from “Parameter to user interface”, “Little Endian (LSB-MSB)” from “Storage format (word module)” and select “Buffered, host controlled” from “Handshake of the process data” in order.

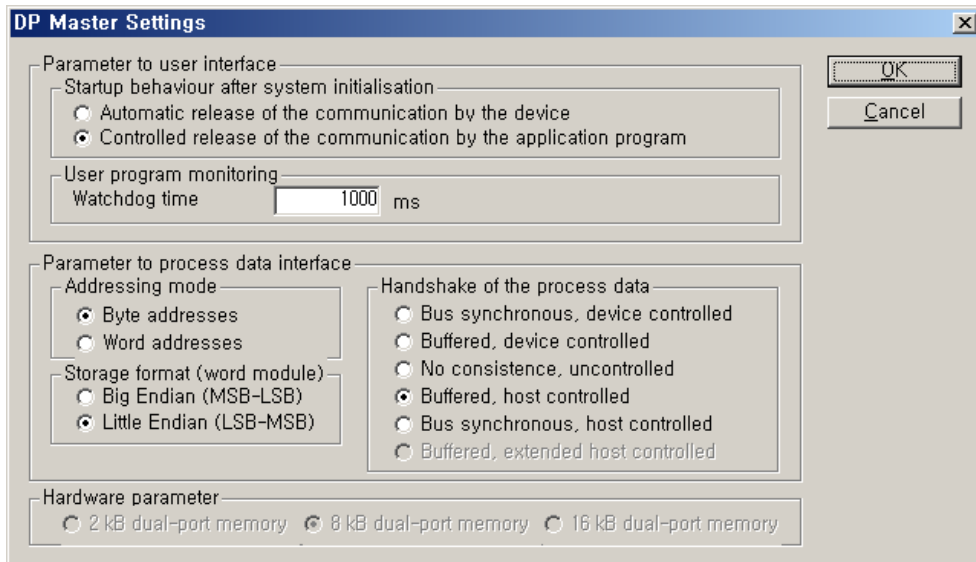

4) Insertion of slave

Similar to master, click “Insert → Slave” or select  from left top tool bar and click master bottom, and Insert Slave window will appear as below.

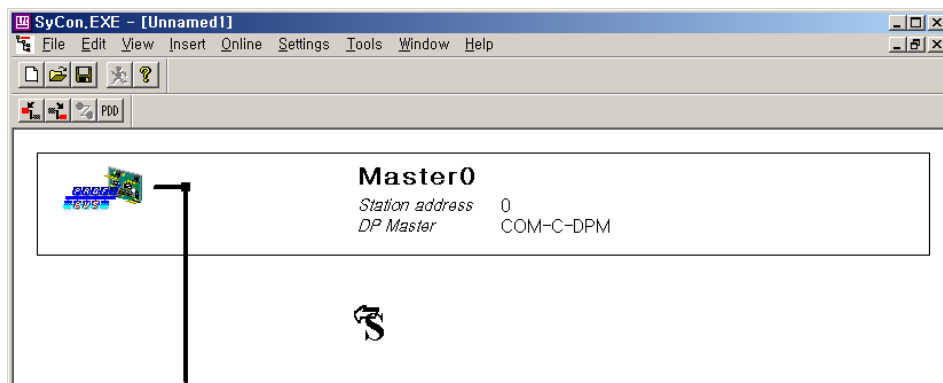

Chapter 5 Profibus-DP Communication

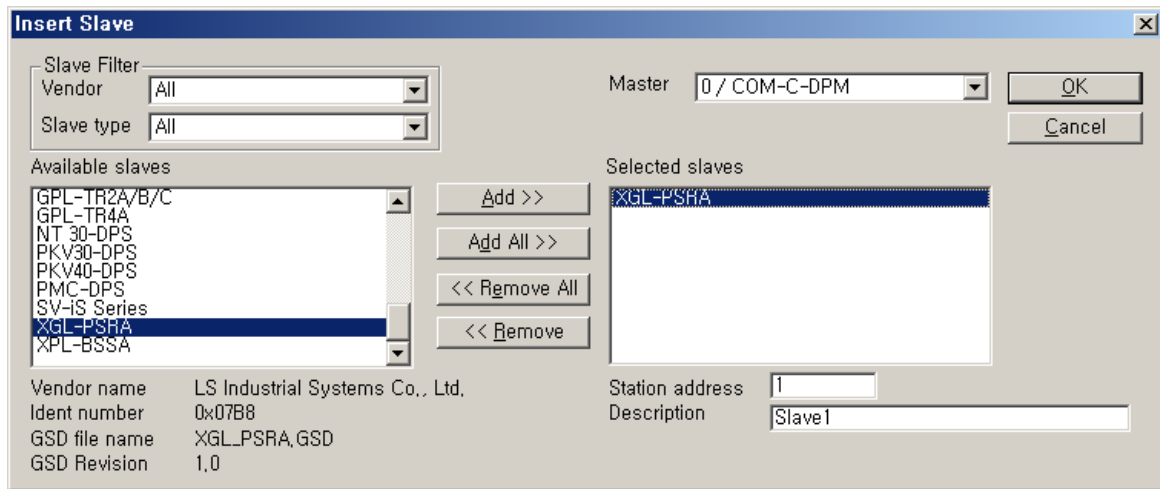

If using XGL-PSRA, select “XGL-PSRA” from the left side “Available slaves” and click “Add” button in the middle part. If there are several masters, select one from the right side “Master” and confirm “Station address” and “Description”, and then click “OK” button.

Note

- 1) If there is no slave to use in the slave list (Available slaves) of insert slave window, copy “GSD file” which is the original self-information supplied by the module manufacturer, from the directory below. Then, try SyCon again and insert slave.

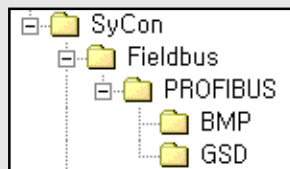

5) Slave Configuration

Click the inserted slave icon with the right button of mouse and select “Slave configuration” from the appeared popup window. (or double-click the left button of mouse on the slave icon.)

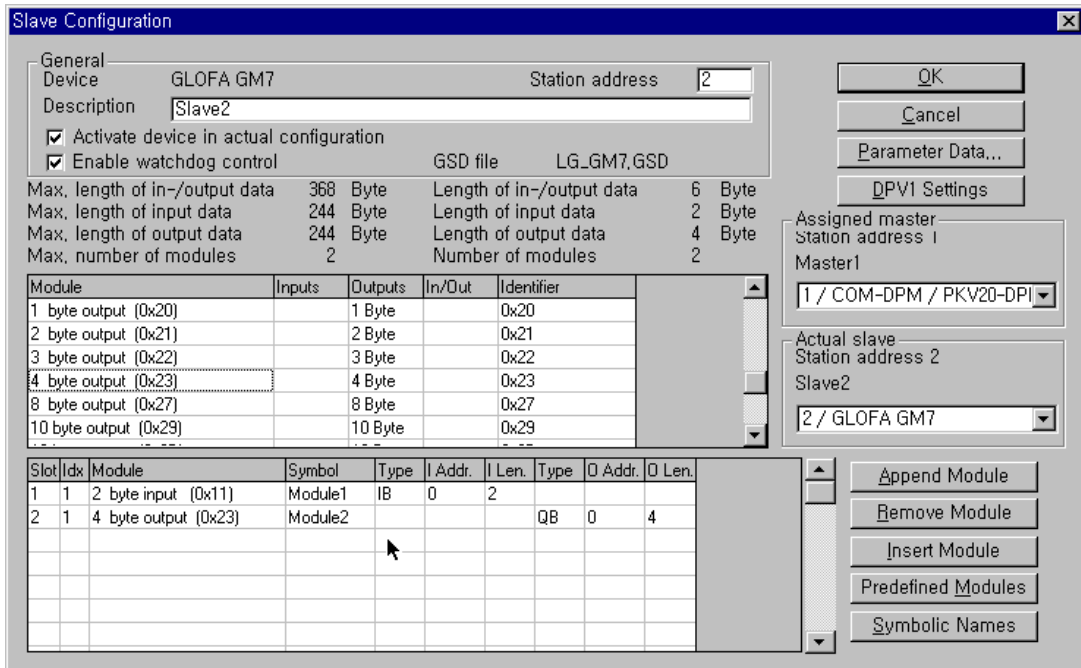

List box in the middle part shows all available modules. If you select the module having the necessary *point* and click “Append Module” button on the right bottom, it shall be inserted to the list box below. In this case, it is required to insert input module first and then insert output module in the bottom. And the numbers of available module are 2.

6) Bus Parameter Setting

Bus parameter setting is the setting about Profibus-DP network. Select “Settings/Bus Parameter...” from the menu. Optimize field contains “Standard” and “user definition” setting. Speed setting (Baud rate) contains 9.6kbps ~12Mbps setting. Basically, Baud rate is set as 1.5Mbps and Optimize is set as ‘standard’

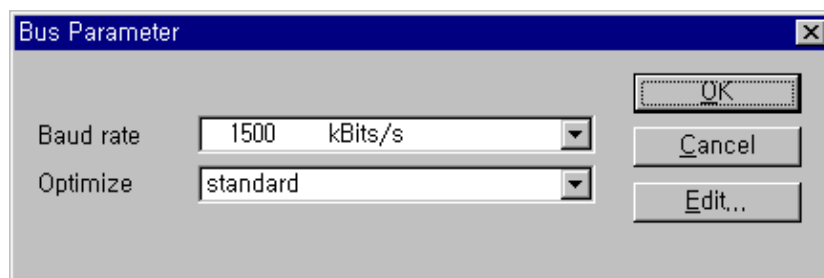

Note

Communication speed is related to transmission distance.
 When using 12Mbps, you should use the connector only for 12Mbps and exclusive cable.
 When using 12Mbps, min. Distance between stations shall be set as more than 1m.
 When using 12Mbps, if the communication is cut off (especially, the station far from master), search the proper end resistance value and set it random.

Chapter 5 Profibus-DP Communication

7) Device Allocation

It is required to download the prepared configuration to the master module. In this case, click the left button of mouse and select master module icon to set which device to use. Select "Setting/Device Assignment..." from the menu.

(1) Device Allocation

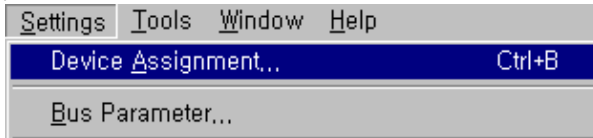

(2) Driver Selection

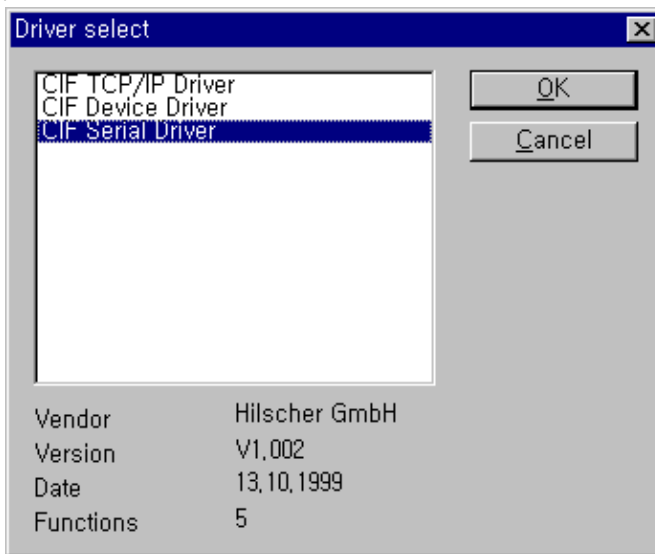

If driver selection window is open, select "CIF Serial Driver".

Note

- 1) Driver to be provided by G3/4/6-PUEA/B, XGL-PMEA type master module is only RS-232C port. Thus, "CIF TCP/IP Driver", "CIF Device Driver" is not available.

(3) Driver Selection of CIF Serial Driver

Device Assignment CIF Serial Driver

Driver Description
Device Driver:

Board Selection

	Name	Type	Version	Date	Error	
<input checked="" type="checkbox"/> COM 1	DPM	COM-DPM	V01.147	14.04.00	0	Connect COM 1
<input type="checkbox"/> COM 2					0	Connect COM 2
<input type="checkbox"/> COM 3					-20	Connect COM 3
<input type="checkbox"/> COM 4					-20	Connect COM 4

Buttons: OK, Cancel

① Press the button "Connect COM1" to confirm if the corresponding module information is indicated.

② If the corresponding module information is indicated, check the "COM1" check box.

③ If everything ends normally without any error, press "OK" button.

Connect PC serial port and Configuration Port of Profibus-DP master module. And apply the power of master module. Press "connect COM1" or other button according to PC serial port and confirm if the corresponding module is selected. On the figure, "Version" and "Date" may have different value. If there is no error, check the check box of the left side and click "OK" button.

Note

- 1) When pressing "Connect COM1" button, if the module information does not appear normally and the error occurs, check the connection of cable for configuration and the cable condition first. If Cable is OK, it means that module must be poor. In this case, contact the customer service center.

Chapter 5 Profibus-DP Communication

8) Configuration Download

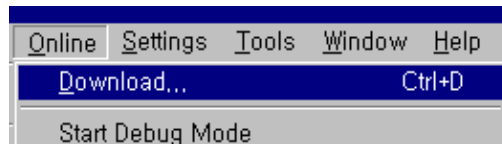

If you select “Online/Download” from the menu, ‘Download’ begins to run. In this case, all LED shall be OFF and only “READY” LED shall be blinking. After downloading, all LED show its function.

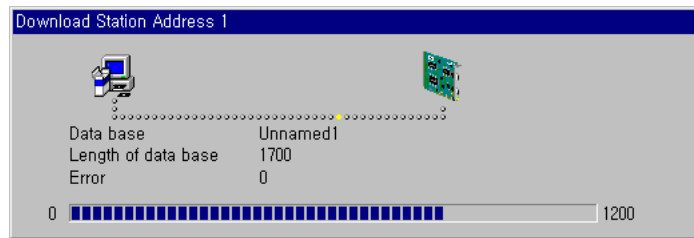

If you carry out ‘Download’ in the status that the communication between the current master and slave is open, the warning window with the message **“if the download is done during the bus operation, the communication between the master and the slaves is stopped.”** will appear. After confirming if there is a problem by communication cutoff, click “Yes(Y)” button and ‘Download’ will run normally.

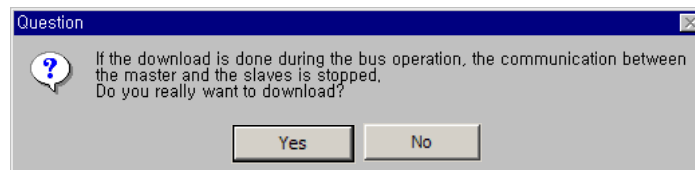

5.4.2 Communication Setting through PROFICON

If you use LSIS's master module (G3/4/6L-PUEA/PUEB, XGL-PMEA), you can configure Profibus Network and download it by using Proficon.

Screen of Proficon is as follows.

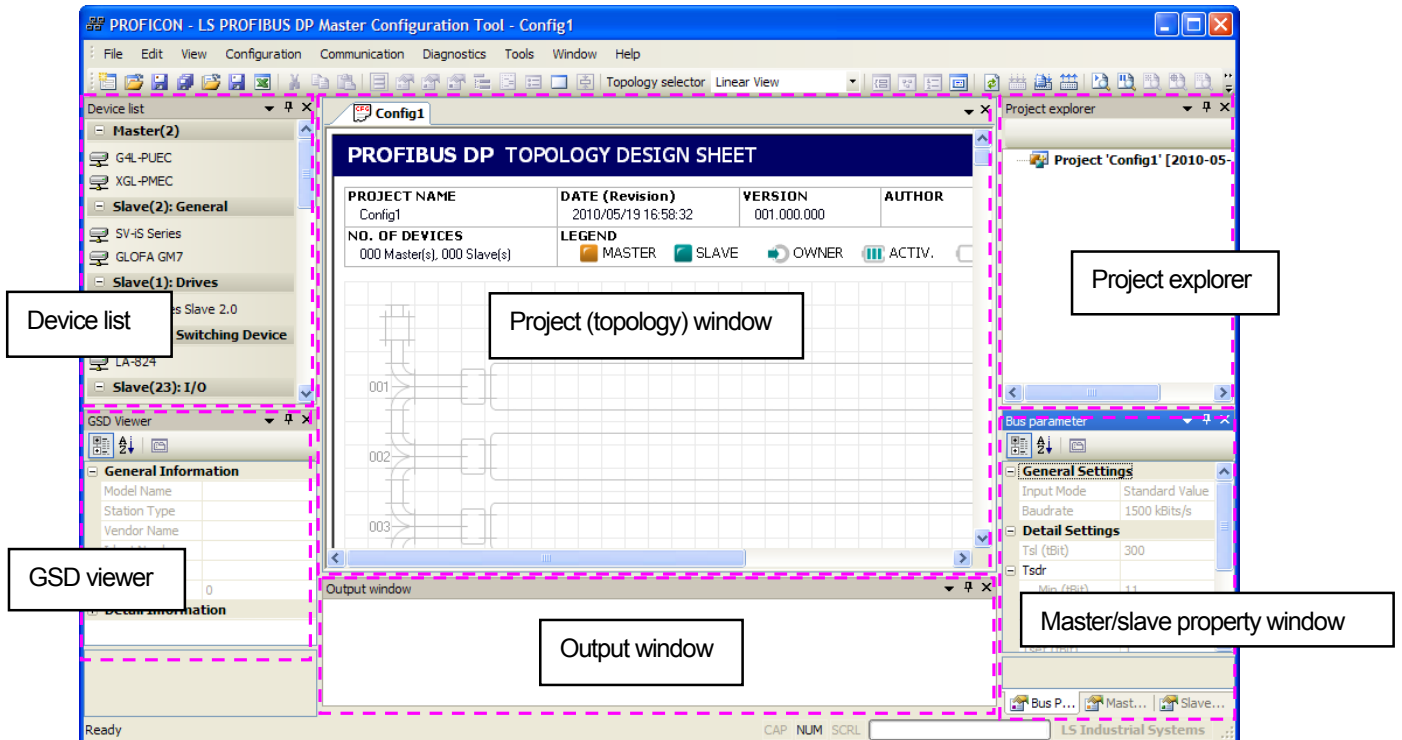

- Device list: List of devices analyzed from GSD. You can drag & drop these devices to Project (topology) Window
- Project: PROFIBUS network topology
- Project explorer: classifies the topology configured in project window in Project-Master-affiliated slave
- GSD viewer: GSD detail information on the device selected from device list
- Output window: operation result of Configuration Tool
- Master property window: sets the properties of master device in the project window
- Slave property window: sets the properties of slave device in the project window
- Bus parameter window: Sets the communication properties of PROFIBUS network in the project window

Chapter 5 Profibus-DP Communication

1) Master configuration

There are master devices at the top of the device list. Select the master you want use as figure below.

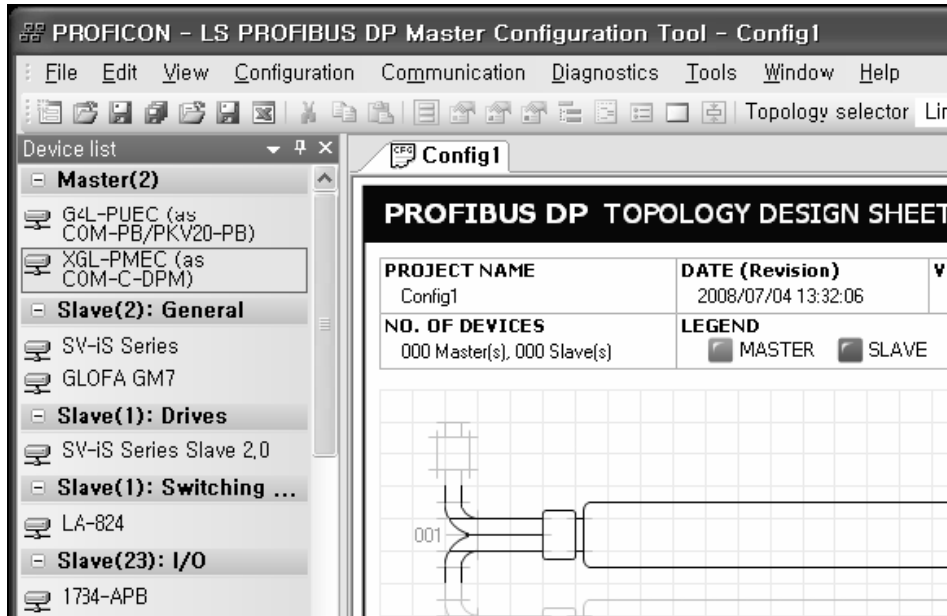

If you want to change the properties of master such as station number or description, press “Master Properties” of “Configuration” menu. Master property window is activated as figure below.

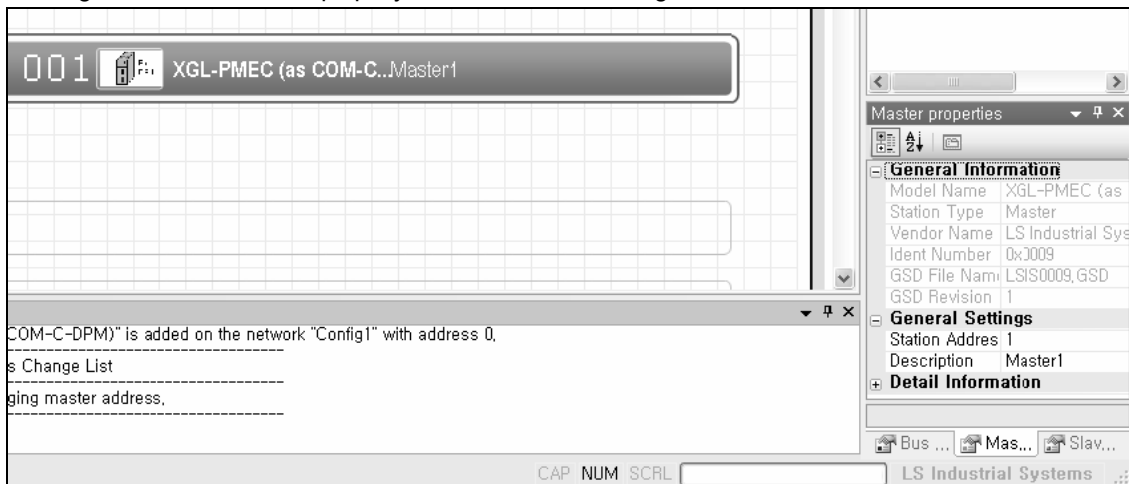

2) Slave configuration

Slave configuration is available after master configuration.

How to configure slave is same as that of master. Select the slave device you want to add in the device list as figure below.

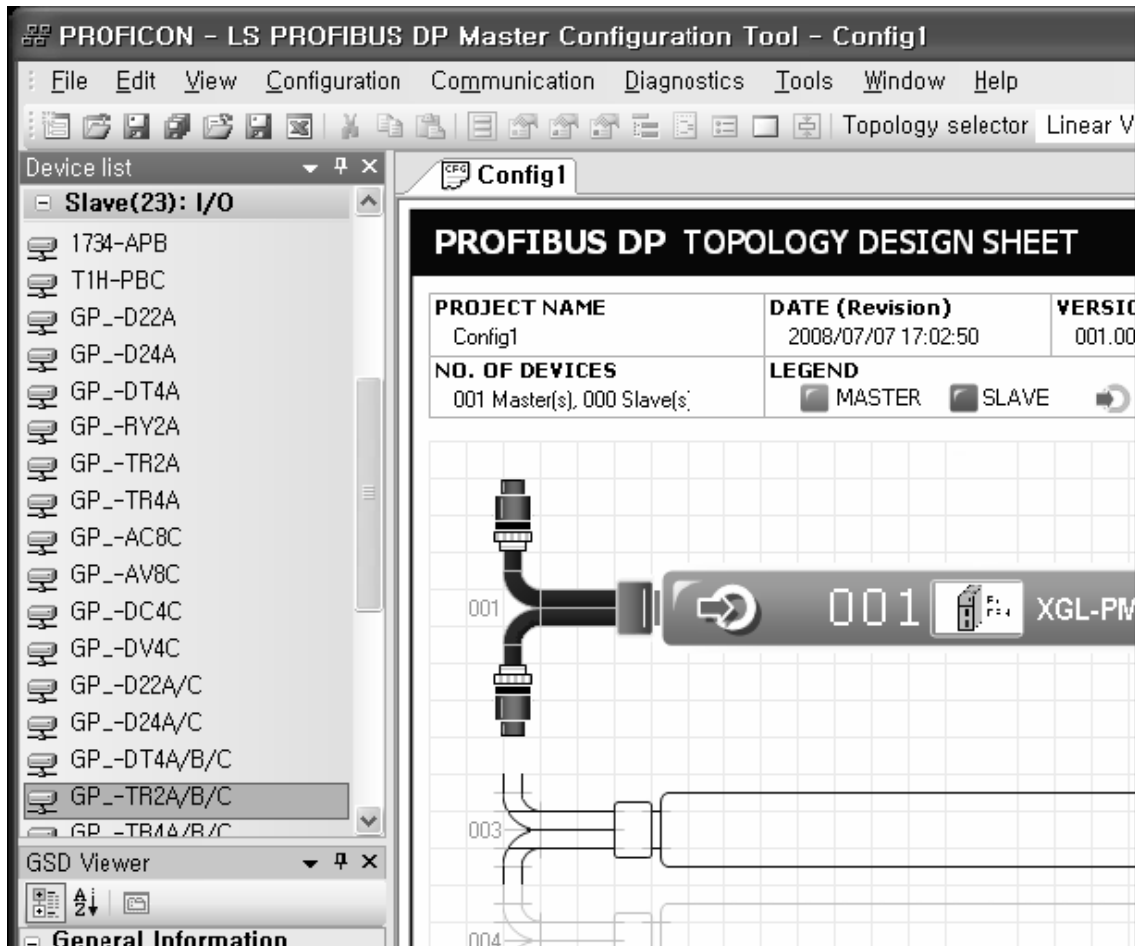

Basically the tool allocates station number in order when adding each device to topology. So if you want to change station number and properties of slave, user "Slave Properties" item of "Configuration" menu.

Affiliated items of "Slave Properties" are as follows

- Station Address
- Description
- Activate Device
- Communication Watchdog
- User parameter setting
- Module setting

For user parameter setting and module setting, additional window appears.

Chapter 5 Profibus-DP Communication

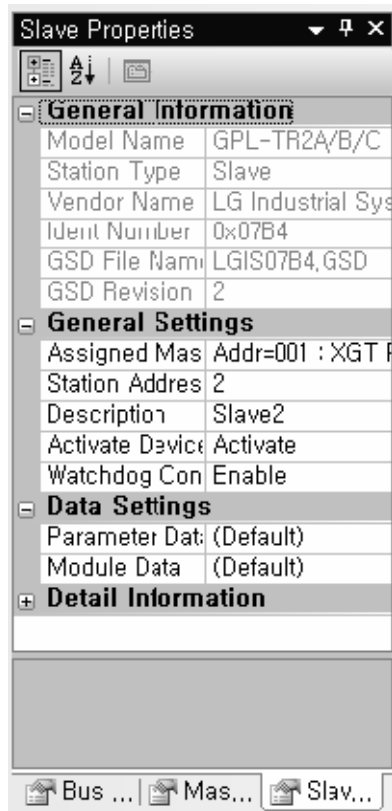

For user parameter setting, “Slave Parameter Settings” window appears as figure below.

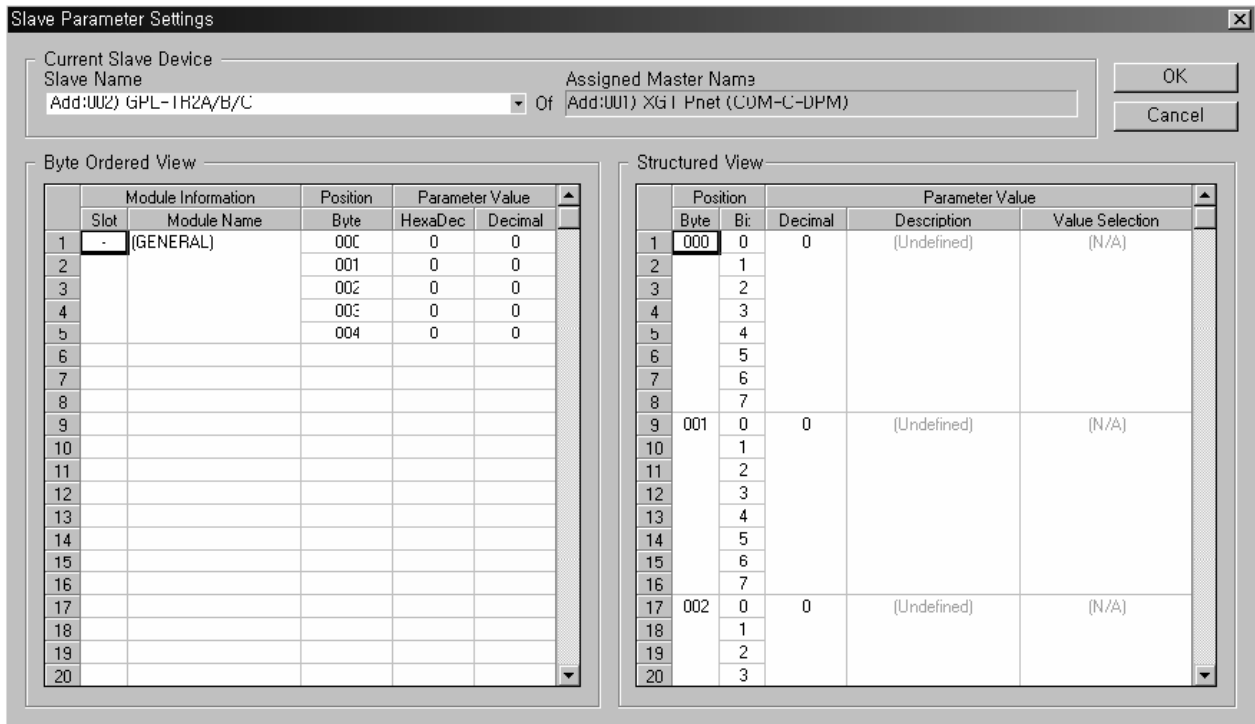

“Slave Module Settings” window is as follows. Double-click the actually configured module in the Module Selection area. If you select wrong module, double-click the module then the module is removed.

Current Slave Device
Assigned Master Name

Slave Name Of Assigned Master Name
Add:002) GPL-TR2A/B/C Add:001) XGT Pnet (COM-C-DPM)

Module Selection

↓	Module Name	Inputs	Outputs	In/Out	Identifier
1	2 Byte Out, 0 Byte In		2 BYTE		0x21 0x00
2					
3					
4					
5					
6					
7					
8					

Input Data (Byte)	Output Data (Byte)	In/Output Data (Byte)	Number of Modules
<input type="text" value="000"/> / Max 000	<input type="text" value="002"/> / Max 002	<input type="text" value="002"/> / Max 002	<input type="text" value="001"/> / Max 001

↓	General Information			Input			Output			General Settings
Slot	Idx.	Configured Module Name	Type	Add.	Len.	Type	Add.	Len.	Module Description	
1	0	1	2 Byte Out, 0 Byte In			BYTE	0	2		
2	0	2	2 Byte Out, 0 Byte In							
3										
4										
5										
6										
7										
8										

| --- DbIClick = Deleting Module ---| ----- DbIClick = Entering Edit Mode (Yellow Cell) -----|

3) Bus parameter

You can change the communication speed or communication parameter through network bus parameter setting. Generally, default value of communication parameter is used so we describe how to change communication speed. Since the master has the right to change network bus parameter, you should select the master in the topology. Then “Bus Parameters” item of “Configuration” menu is activated

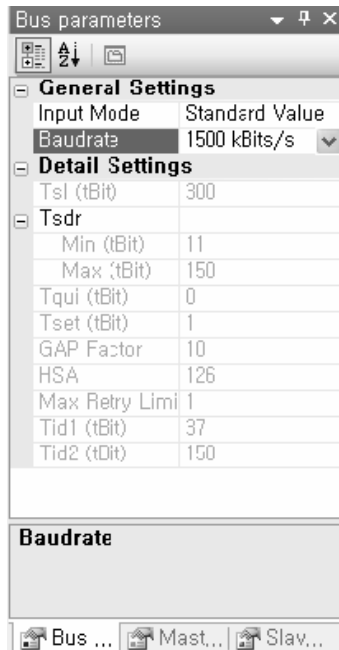

If you select PROFIBUS DP communication speed (Baudrate) you want, bus parameter will be applied.

4) Configuration download and upload

PROFIBUS DP master operates based on Network configuration data. For this, you should download the network configuration data to master. And you can read the downloaded configuration data from master (Upload function). Here Pnet I/F module of XGT PLC, XGL-PMEC is used for example.

(1) Communication connection settings

To download the Network Configuration set in Topology window to XGT Pnet master, first you should connect XGT PLC

If you select "Settings..." item of "Communication" menu, the window below appears. Select "Communication With XGT" and input the information on the PROFIBUS DP master module position and click "OK"

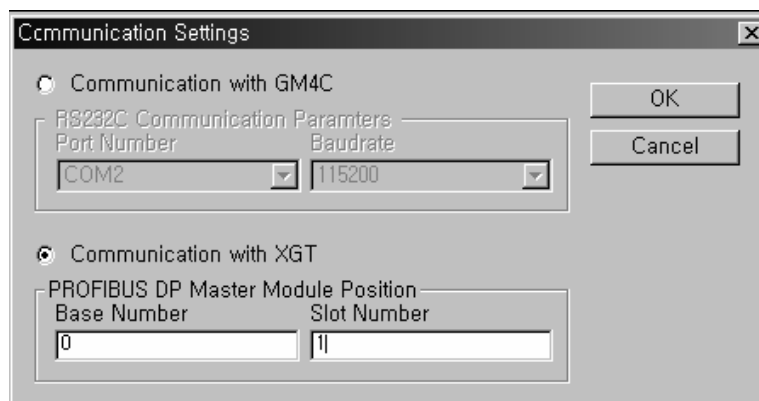

Then XGT CPU "Connection Settings" window appears. After setting, press "OK" button and complete the connection setting.

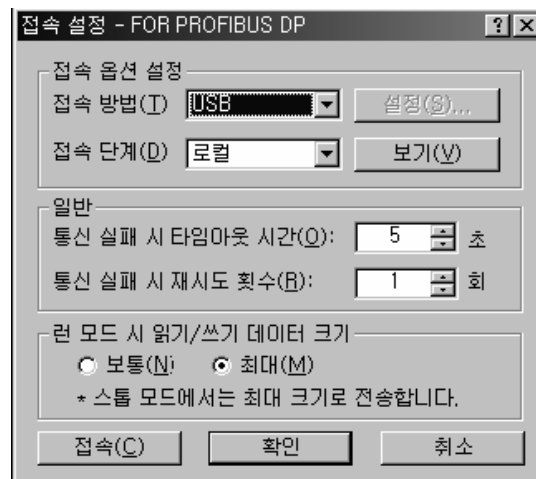

Chapter 5 Profibus-DP Communication

(2) Network Configuration download

After configuring network in the topology, if you select “Download Image” item of “Communication” menu, downloading will start. The figure below displays downloading status. Progress Bar operates in the status bar and Process Rate is displayed in the output window.

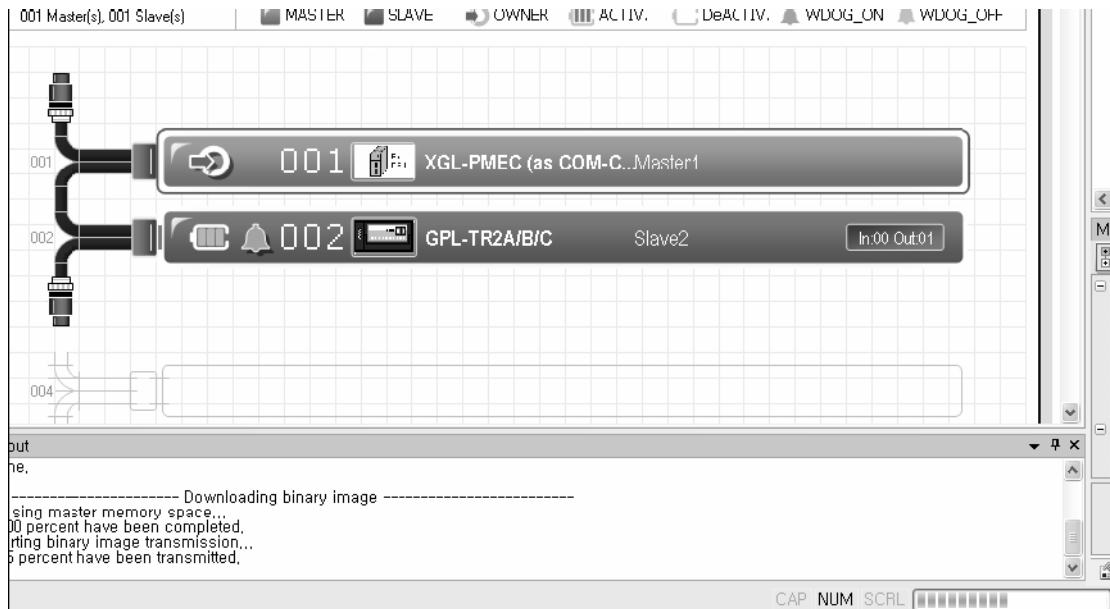

If downloading is complete, Progress Bar becomes full and “Done” is displayed in the output window.

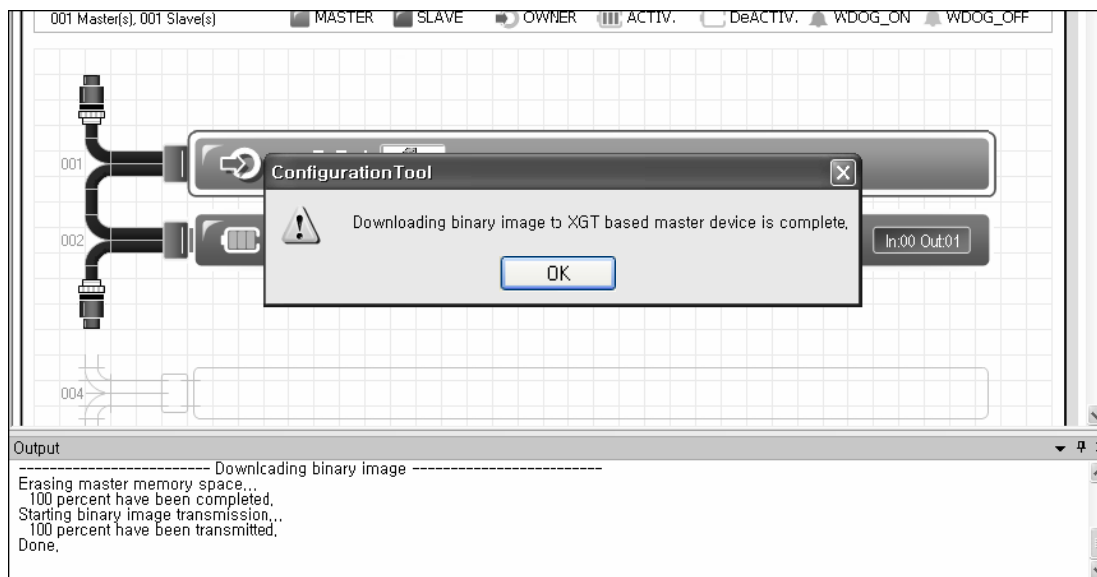

(3) Network Configuration upload

If you select "Upload Image" item of "Communication" menu, uploading will start. At this time, project is created automatically.

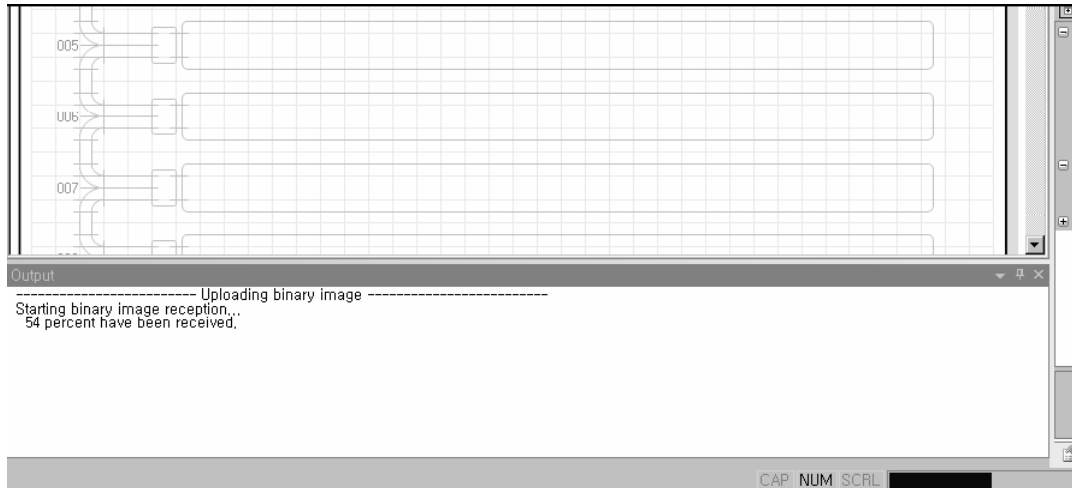

If uploading is complete, "Done" is displayed in the output window and Network Configuration read form master is displayed in the project topology window.

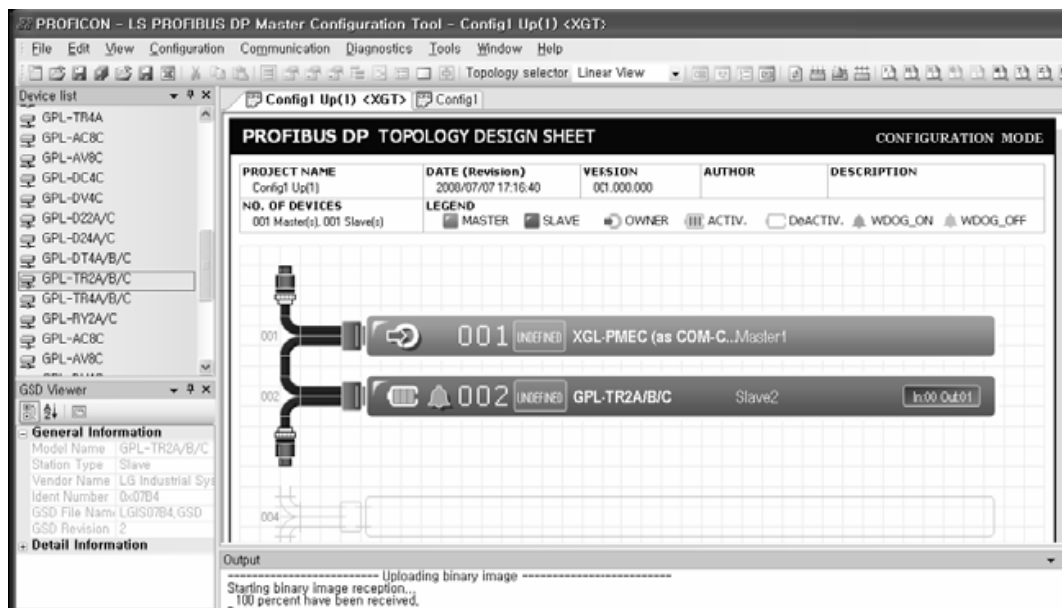

5.5 High Speed Link Setting

5.5.1 High Speed Link Setting in GMWIN

In the previous article, we explained the method to set Configuration and the method to download this to the master module. **High-speed Link parameter setting should be done after downloading Configuration.** And *High-speed Link* parameter is set by selecting link parameter from GMWIN project screen and setting the corresponding items. The setting order and its functions per item are as follows.

1) *High-speed Link* parameter setting in GMWIN

Open *High-speed Link* parameter from Project basic screen and enter into the *High-speed Link* parameter setting menu

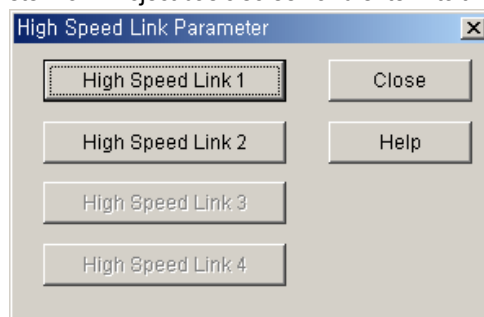

The number of activated “*High-speed Link*” item of the above figure means the maximum Installation number of communication module according to PLC CPU type. Available “High-speed link” is activated and in this case, *High-speed Link* no. is not related to the installed slot no. and the slot no. should be set in the individual parameter setting screen and only one *High-speed Link* parameter is available per one communication module.

(1) Max. Installation number per GLOFA-GM CPU model

Classification	Available communication module	Max. installation number	Remarks
GM3-CPUA	G3L-PUEA, G3L-PUEB	4	If combined with other communication module using HS link, installation number shall be limited.
GM4-CPUA/B	G4L-PUEA, G4L-PUEB	2 (A type) / 4 (B type)	
GM6-CPUA/B/C	G6L-PUEA, G6L-PUEB	2	

2) Link parameter setting

If you select the corresponding parameter from parameter setting basic screen, the *High-speed Link* parameter setting initial screen will appear as shown in the following figure.

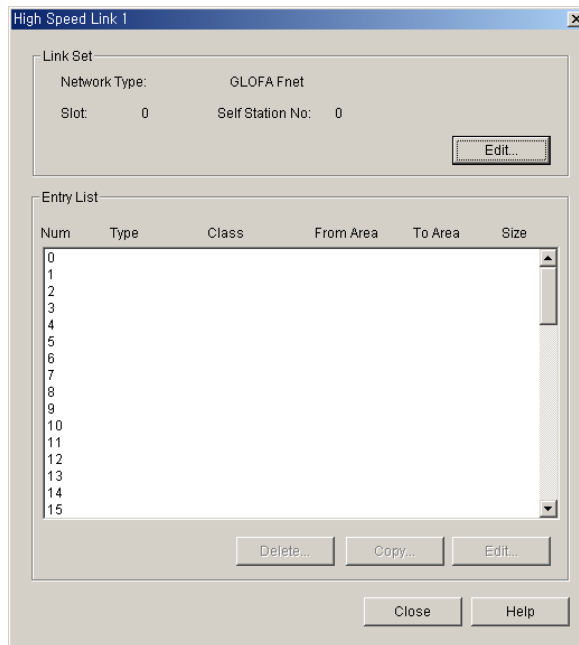

Parameter setting initial screen is composed of two items such as 'link set' and 'Entry list'. The setting method per each item and its function are as follows

3) High-speed Link setting

"Link Set" is the item to set the basic items of the communication module. Select 'Edit' button of "link set" and set network type, slot no. the self station no. in the *High-speed Link* setting screen.

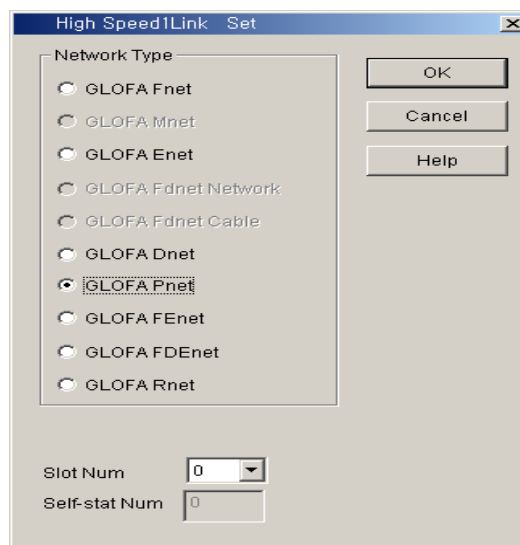

Chapter 5 Profibus-DP Communication

- Network Type: It sets the installed communication module type and GLOFA Pnet should be set.
- Slot Num: It sets the position of the communication module. (0 ~ 7 slot).
- Self-station Num: The master module' station no. shall be set in SyCon and the slave module's station no. shall be set by rotary switch. It is not available to change station number here.

4) Entry List setting

Entry list is the area to register the TRX information of actual data after link setting. It is required to set in the registration no. '0' of Entry list area, and the major setting items are shown on the top of registration list menu. Select (or double-click) the corresponding list from *High-speed Link* setting screen and the user can set the corresponding item from "*High-speed Link* item Edit" window as shown on the figure below.

The screenshot shows a dialog box titled "High Speed Link Item Edit". It has a tabbed interface with "Area" selected. The "Receive area" section has radio buttons for %MW (selected), %IW, and %QW, with an "Address" field set to 100 and a "Size(Byte)" field set to 0. The "Transmit area" section has radio buttons for %MW (selected), %IW, and %QW, with an "Address" field set to 200 and a "Size(Byte)" field set to 32. At the bottom are "Ok", "Cancel", and "Help" buttons.

The following shows the screen after setting the TRX parameter. Double-click the corresponding registration no. to modify the parameter.

The screenshot shows a dialog box titled "High Speed Link 1". It has a "Link Set" section with "Network Type: GLOFA Pnet", "Slot: 0", and "Self Station No:". Below this is an "Entry List" table with the following data:

Num	Type	Class	From Area	To Area	Size
0	%MW100	0	%MW200	32	

At the bottom of the dialog are "Delete...", "Edit...", "Close", and "Help" buttons.

The function of each registration item is as follows.

- Area: When sending, set the area to send and when receiving, set the storage area of the received data.
- Size: This means the data size to send/receive and the unit is 1 byte, and it is available to set total size as 1Kbyte for G3/4/6L-PUEA and 7Kbytes for G3/4/6L-PUEB.

Remark

- 1) The size of receive/transmit area is total I/O contact number made in SyCon.
- 2) The order of module is as follows.
 First, G4L-PUEA 1 and GPL-TR2A (16 points), GPL-TR4A (32 points), GPL-D22A (16 points) and when setting the transmit area as %MW0, the receiving area as %MW100,
 - Transmit area : %MW0
 - Receive area : %MW100
 - Size of transmit area : 6 bytes (total output contact number)
 - Size of receive area : 2 bytes (total input contact number)
 And,
 - %MW0 data -> GPL-TR2A output
 - %MW1 ~ %MW2 data -> GPL-TR4A output
 - GPL-D22A input -> %MW100 saved
- 3) The order of module programmed in SyCon has higher priority than station no. and cable connection when sending/receiving the data.

5) High-speed Link Information

High-speed Link service provides the user with the method to confirm *High-speed Link* service status to confirm the reliability of the data read from other station through *High-speed Link* as *High-speed Link* information because this is data exchange between more than 2 communication stations.

That is, the communication module provides the user with the high link information every regular time by collecting all data received until then about whether the *High-speed Link* action is done by the parameter set by the user or not. The *High-speed Link* information contains the overall information such as RUN-LINK (`_PHSxRLINK`), LINK-TROUBLE (`_PHSxLTRBL`) that provides the user with overall information of communication network and the individual information such as `_PHSxSTATE` that informs the communication status per slave station. The user can use the above information as keyword type when preparing the program and monitor the *High-speed Link* status by using the *High-speed Link* information monitor function. When operating several PLC using *High-speed Link*, it is required to confirm the reliability of the sending/receiving data using the *High-speed Link* information such as RUN-LINK, LINK-TROUBLE etc.

(1) Run-Link (`_PHSxRLINK`)

This is the overall information that shows whether or not *High-speed Link* is running normally by the parameter set by the user. Once 'ON', it maintains 'ON' until link enable is 'OFF' and if the following condition is given, it shall be 'ON'.

- a) When 'Link Enable' is 'ON' .
- b) When parameter registration list setting is set normally all.
- c) When sending/receiving all data that corresponds with parameter registration list within the setting period.
- d) When all other station status set in the parameter is 'RUN' and at the same time there is no error.

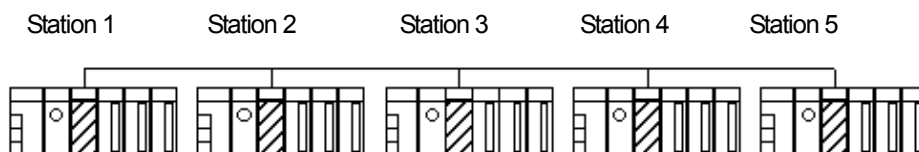

Chapter 5 Profibus-DP Communication

Example of High-speed Link parameter setting of each station

Station 1	Station 2	Station 3	Station 4	Station 5
send: 2 words receive: 2 words (station 2) receiving: 2 words (station 3)	sending: 2 words receiving: 2 words (station 1) receiving: 2 words (station 4)	sending: 2 words receiving: 2 words (station 1) receiving: 2 words (station 5)	sending: 2 words	sending: 2 words

The figure shows *High-speed Link* system configuration to explain RUN-LINK ON condition. In case that 5 communication modules are connected by network as shown on the above figure and carry out *High-speed Link* as the content of parameter, RUN-LINK ON condition of Station 1 is as follows.

- ① When in the self station (station 1), Link-Enable is 'ON' ,
- ② When the self station (station 1) is RUN status,
- ③ When the self station (station 1) is not the error status,
- ④ When the sending parameter data set in the self station (station 1) is sent properly,
- ⑤ When the data receiving from station 2, 3 is received properly,
- ⑥ When the action mode of other station (station 2, 3) to send the data to the self station (station 1) is RUN mode, not the error status and it is communicated properly,
- ⑦ When in the other station (station 2, 3) of the self station (station 1), the action mode of other station (station 4, 5) set in the parameter is RUN mode and not the error status and it is communicated properly.

If the above 7 items are satisfied, RUN-LINK of station 1 shall be ON. If using RUN-LINK contact associated with program in the system where PLC of various stations perform interlocking through *High-speed Link*, it is available to carry out the mutual monitoring of sending/receiving data and the reliable communication. But, once RUN-LINK contact is 'ON' , it maintains 'ON' status until Link-Enable becomes 'OFF' . Thus when monitoring the abnormal status such as on communication error, it is required to use 'LINK-TROUBLE' information contact together as follows.

(2) LINK-TROUBLE (_PHSxLTRBL x=High-speed Link no.(1~2))

This is the overall information indicating whether the *High-speed Link* is running normally by the parameter set by the user. When RUN-LINK violates the condition of RUN-LINK ON in the status that RUN-LINK is ON, LINK-TROUBLE shall be 'ON' and if recovered, it shall be 'OFF' .

(3) High-speed Link status (_PHSxSTATE[0..127] x=the slave station no. (0~127))

This is the individual information indicating the action status of the slave station and this is available to indicate max. 127 stations *High-speed Link* status same as max. slave station number. That is, if the sending/receiving status of the corresponding list is normal and the action mode is RUN and there is no error, it shall be 'ON' and if violating the above condition, it shall be 'OFF' .

6) High-speed Link information monitoring

High-speed Link information enables to monitor using the monitoring function after GMWIN online connecting. There are two kinds of method to monitor: the method to select 'variable monitor' from monitor menu and the method by link parameter monitor.

(1) Variable monitor

The variable monitor is the function to monitor by using GMWIN flag monitor function and selecting the necessary item. If you select 'variable monitor' from online monitor item, the variable registration screen will appear as below. Select the flag and register by selecting directly the *High-speed Link* information flag from variable, flag list screen one by one. In this case, as PHSxSTATE[n] is Array type flag, the user should select the array no. directly and the array no. means the slave station no. Also, 'x' means the *High-speed Link* no. and it has the range 1~4 for GM3 PLC CPU, the range 1~2 for GM4 PLC CPU, and the range 1 for GM6 PLC CPU. If you register the variable in the figure below and select 'close', the monitor screen will appear and if you press 'start' from tool box shown on the right side separately, it begins to monitor.

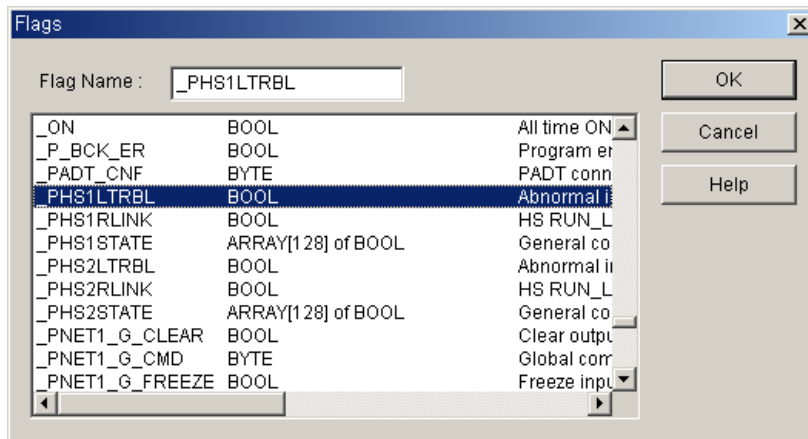

High-speed Link information monitor screen (Variable registration)

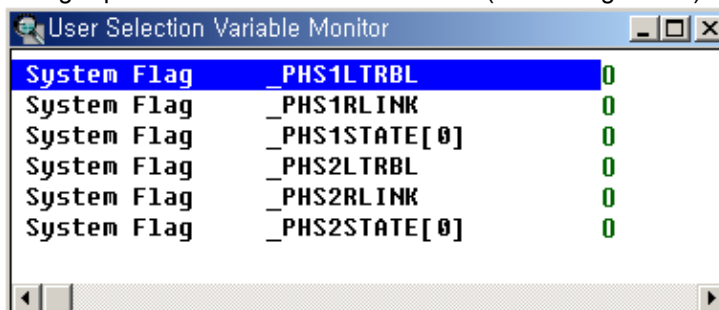

Chapter 5 Profibus-DP Communication

(2) Link parameter monitor

If you select 'link parameter' item from monitor menu of GMWIN online connection, 'Select Link Parameter' screen will appear as shown on the figure below. If the user selects the desired item from parameter number set by it and verify it, the *High-speed Link* parameter monitor screen will be open and the setting registration list will be monitored and indicated on the screen.

Link parameter selection screen

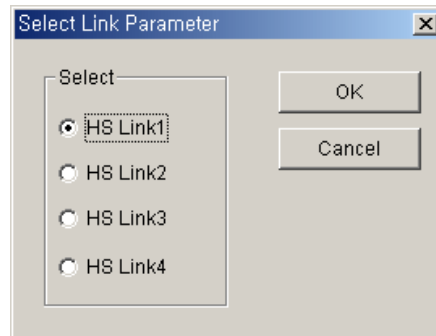

Link parameter monitor indicates the general information such as RUN-LINK, LINK-TROUBLE on the right top and the individual information for mode (action mode), communication (sending/receiving status), error with registration list no.

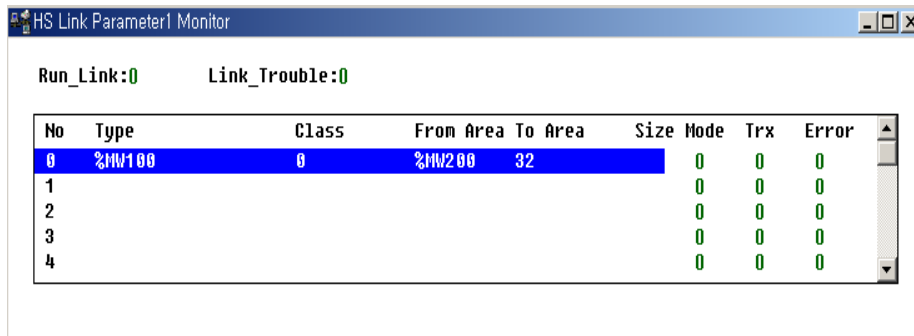

No	Type	Class	From Area	To Area	Size	Mode	Trx	Error
0	%MW100	0	%MW200	32	0	0	0	0
1					0	0	0	0
2					0	0	0	0
3					0	0	0	0
4					0	0	0	0

If selecting the *High-speed Link* information monitor as shown on the above figure, the *High-speed Link* parameter and information set by the user will be monitored together. And it is available to monitor the *High-speed Link* status with I/O data as the individual information setting value is monitored together.

5.5.2 High-speed Link Parameter Setting in KGLWIN

Profibus-DP master for MASTER-K also uses SyCon for the Configuration setting and the setting method is the same as that of GLOFA-GM. In case of MASTER-K, it should be required to set the *High-speed Link* parameter after downloading the Configuration to the master module and the *High-speed Link* parameter selects the parameter from KGLWIN project screen and set the corresponding item. The setting order and the function per item are as follows.

1) High-speed Link parameter setting in KGLWIN

If selecting 'parameter' from the following project basic screen, the *High-speed Link* parameter basic screen will appear and you can select the corresponding item.

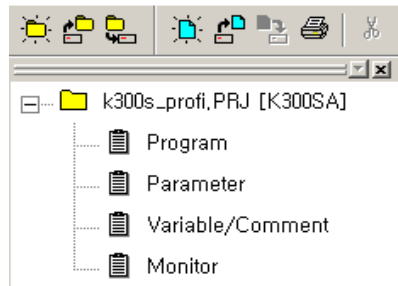

2) High-speed Link parameter selection

(1) Setting method

Select the corresponding parameter from the basic screen as shown on the figure below and enter into the parameter setting.

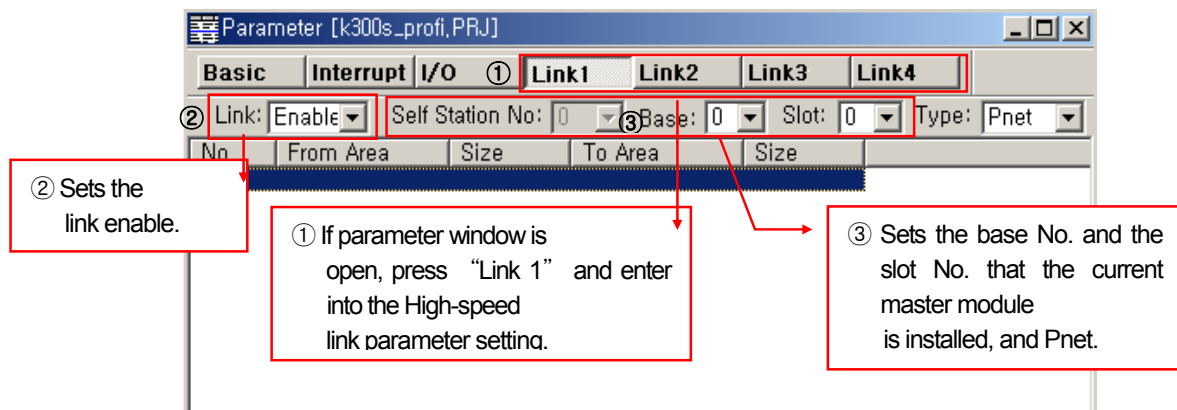

Chapter 5 Profibus-DP Communication

The *High-speed Link* item tab of the above figure means max. installation number of communication module according to PLC CPU type. The *High-speed Link* button as much as the available setting number shall be active and in this case, the *High-speed Link* no. is not related to the installed slot no. and the slot no. shall be set in the individual parameter setting screen and only one *High-speed Link* parameter is available to set for one communication module.

The following table shows the communication model available to install per MASTER-K CPU model and max. installation number.

Max. installation number per MASTER-K CPU model

Classification	Available communication module	Max. installation number	Remarks
K1000S CPU	G3L-PUEA, G3L-PUEB	4	-
K300S CPU	G4L-PUEA, G4L-PUEB	2 / 4 (Above version 3.0)	
K200S CPU	G6L-PUEA, G6L-PUEB	2	

* If combined with other communication module using the High-speed Link, the installation number shall be limited.

- Link: This is the item to allow the *High-speed Link* and the initial value is prohibited and it is required to set 'enable' to execute the *High-speed Link*.
- Self station no. : Master module is set in SyCon and the slave module is set as rotary switch. It is not available to change here.
- Base: It sets the base position that the communication module to set is installed.
- Slot: It sets the position that the communication module to set is installed. (0 ~ 7 slot).
- Type: It sets the type of the installed communication module and sets the Pnet.

3) Parameter setting and modification

If you double-click the corresponding parameter from the parameter setting basic screen as shown on the figure below, the *High-speed Link* parameter setting screen will appear.

- Area: When sending, set the area to read the data to send and set the storage area of the received data when receiving.
- Size: This means the data size to send/receive and the unit is 1 byte and it is available to set total sending/receiving as 1Kbytes for G3/4/6L-PUEA and 7Kbytes for G3/4/6L-PUEB

Remark

- 1) The size of sending/receiving area is the total I/O contact number made in SyCon.
- 2) The order of setting is carried out as G4L-PUEA 1 and GPL-TR2A(16 points), GPL-TR4A(32 points), GPL-D22A(16 points) and when setting sending area as P000, the receiving area as P010,
Sending area : P000
Receiving area : P010
Size of sending area : 6 bytes(total output contact number)
Size of receiving area : 2 bytes(total input contact number),
And,
P000 data -> GPL-TR2A output
P001~P002 data -> GPL-TR4A output
GPL-D22A input -> P010 saving.
- 3) The setting order programmed in SyCon has the priority when sending/receiving the data than station no. and cable connection.

5.5.3 High Speed Link Setting in XG-PD

1) Operation sequence of High-speed link

No.	SW applied	Operation	Details
1	SyCon or PROFICON	Execute dedicated configuration tool	For XGL-PMEA, execute SyCon and for XGL-PMEC, execute PROFICON
2		Set network Configuration	Refer to Chapter 6 SyCon Setting (XGL-PMEA) or Chapter 7 PROFICON setting (XGL-PMEC)
3		Connect to communication port	Refer to Chapter 6 SyCon Setting (XGL-PMEA) or Chapter 7 PROFICON setting (XGL-PMEC)
4		Download network Configuration	Refer to Chapter 6 SyCon Setting (XGL-PMEA) or Chapter 7 PROFICON setting (XGL-PMEC)
5	XG-PD	Execute XG-PD	XG5000 → Tool → Network Manager
6		Create new file	File → New file Set project name and project type
7		Set XG-PD connection	Select applicable connection driver through XG-PD → Online → Connect.
8		Connect to XG-PD	XG-PD → Online → Connect
9		IO Information Read	XG-PD → Online → Read IO Information
10		Define High-speed link project	Select "High-speed Link" on the XG-PD screen
11		Set communication module and communication period	Select one among "High-speed link 1" ~ "High-speed link 12" and double-click it to specify module type, base No., slot No. and period type
12		Upload SyCon	Double-click the created "Block" and click Online → SyCon Upload on the "High-speed Link" screen
13		High-speed Link Block Setting	Double-click the cell on the "High-speed Link" screen 1) For Send : specify Read area (CPU area) 2) For Receive : specify Save area (CPU area)
14		High-speed Link Parameters Write	Online → Write Parameter: check applicable High-speed link so to write
15	High-speed Link Enable	Online → Enable Link: enable applicable High-speed link	

Operation sequence of High-speed link

2) High Speed Link Parameter Setting

High-speed link parameter setting is set in High-speed link screen in XG-PD.

(1) Execution of XG-PD and creation of new file

If XG-PD is executed firstly, the menu is as shown below. XG-PD is executed 'Tools' → 'Network Manager' or click the icon of XG-PD in XG5000.

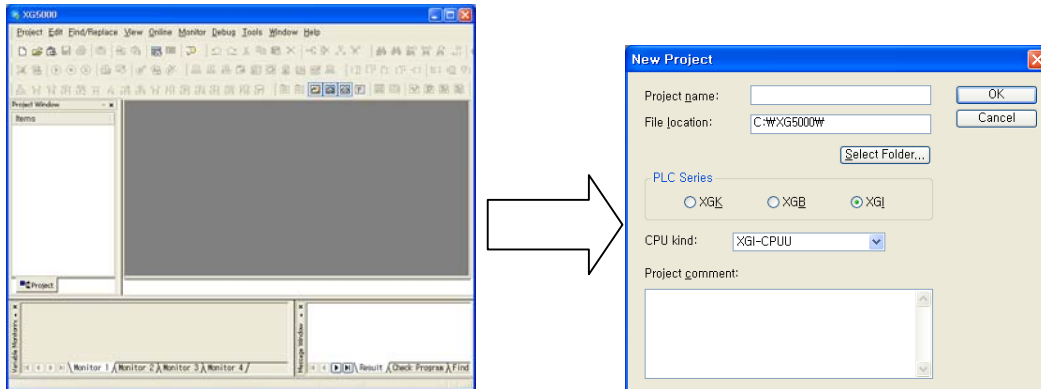

Basic screen of XG-PD

Item	Contents	Remark
Project name	Input project name on XG-PD	-
File location	Directory where project will be saved	-
PLC series	Select XGK or XGI	-
CPU kind	Select CPU kind	-
Project comment	Input project comment	-

(2) Setting of XG-PD connection

It designates the way of XG-PD connection with CPU. "Online" → "Connection Settings"

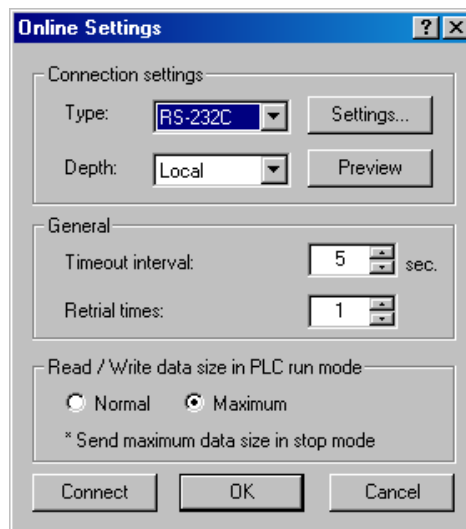

Connection settings

Chapter 5 Profibus-DP Communication

Items		Description
Connection option settings	Connection method	RS-232C, USB
	Connection steps	Local/Remote connection setting Local: Connection of from PC to CPU Remote: Connection from PC to CPU via communication module
Common	Timeout time when communication failure	1~9 seconds
	Retried number when communication failure	1~9 times

Setting of connection option

(3) XG-PD connection

XG-PD is connected to CPU by “Online” → “Connect”.

(4) Read I/O information

Select “Online” → “Read IO Information” to read modules installed on the base.

Surely execute “Read IO Information” for High-speed link setting.

(5) High-speed link project

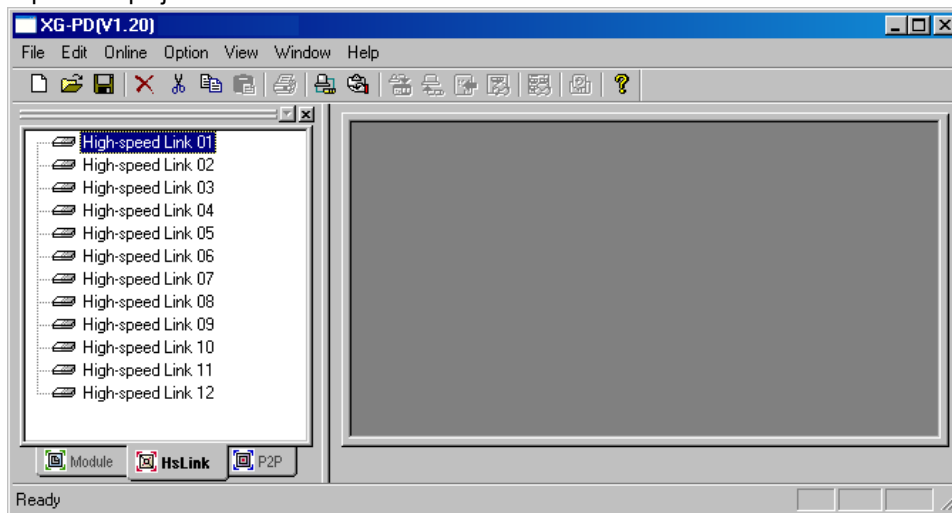

Initial screen of High-speed Link Setting

(6) Communication module and Communication period setting

If double-click the High-speed link, screen of Communication module settings and Communication cycle settings is opened. In this screen, communication module, communication and Output data setup in case of emergency settings period can be specified.

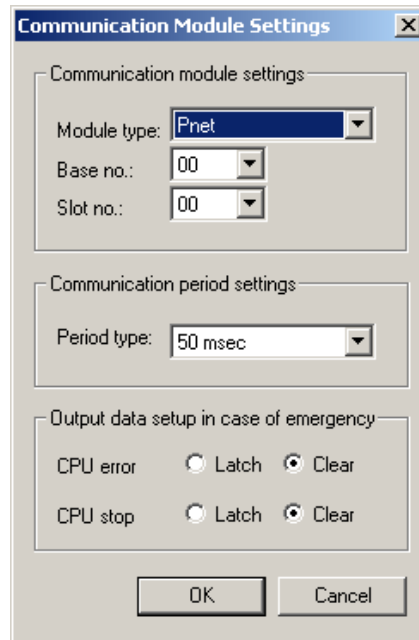

High Speed Link setting initial screen

Items		Description
Communication module settings	Module type	Setting of communication module installed Applicable module: FENet, FDEnet, Dnet, Rnet, Pnet
	Base No.	Setting of base position installed (Maximum 7 bases allowed) Range of Setting: 0 ~ 7
	Slot No.	Setting of slot position installed (Maximum 12 slots allowed) Range of Setting: 0 ~ 11
Communication period settings	Period type	<ul style="list-style-type: none"> - It is set to transmit the data time every period. - Range of setting: 20 ms, 50 ms, 100 ms, 200 ms, 500 ms, 1s, 5s, 10s (default is 20 ms) - But Receive data will be updated data in every scan regardless of communication period. - Communication period will be applied to all of the Send/Receive blocks.
Output data setup in case of emergency settings	CPU error	- Data is latched or cleared when CPU is on Error.
	CPU stop	- Data is latched or cleared when CPU is Stop.

Setting of communication module

Chapter 5 Profibus-DP Communication

(7) SyCon Upload

After "Setting of communication module and communication period" is complete, click the mouse cursor positioned on High-speed link window (right screen of XG-PD), and select "Online" → "SyCon Upload" to upload SyCon's configuration file.

(8) Setting of High-speed link block

Double-click the applicable index number of Configuration file uploaded and designates the 'Read area' and 'Save area' of Send/Receive.

Index	Master Station No.	Station number	Mode	Read area	Sending data (Byte)	Save area	Receiving data (Byte)
0	0	1	Receive				2
1	0	2	Send		2		
2							
3							
4							
5							
6							
7							
8							
9							
10							

High-speed ...

Setting of High-speed link block

Classification	Details	
Master Station No.	Display the Master station no.	
Station No. *1	Setting range for the slave : 0 ~ 126 If identical station No. is set, communication will not be normal.	
Mode *1	Sending: Transmission the data from master module to slave module. Receiving: Transmission the data from slave module to master module.	
Read area (Master module → Slave module)	XGK	Area to set the start address of device used for Sending. Setting device : P, M, K, F, T, C, U, Z, L, N, D, R, ZR
	XGI	Area to set the start address of device used for Sending. Setting device : A, M, I, Q, R, W, F, K, L, N, U
Save area (Slave module → Master module)	XGK	Area to set the start address of device used for Receiving. Setting device : P, M, K, F, T, C, U, Z, L, N, D, R, ZR
	XGI	Area to set the start address of device used for Receiving. Setting device : A, M, I, Q, R, W, F, K, L, N, U
Send data Receive data (Byte)	Display input/output points of slave module by the bytes. - In case of I/O module of 8 bits or less, please set 1 byte.	

*1 : Area is not able to set

Setting of High-speed link block

(9) Write the High-speed link parameter

Click "Online" → "Write Parameters" in XG-PD, check the applicable High-speed link and then click [OK].

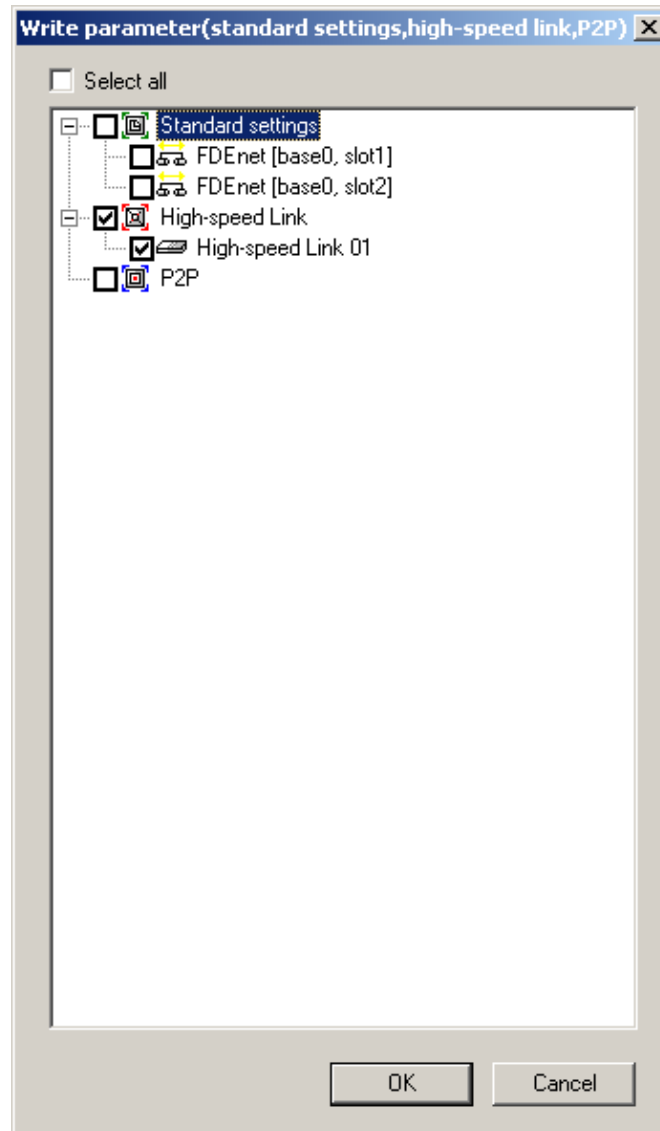

Screen of Write the parameter

Chapter 5 Profibus-DP Communication

(10) Enable of High-speed link

Click "Online" → "Link Enable" in XG-PD, check the applicable High-speed link and then click [Write]. If High-speed link is enabled, on the module's LED display High-speed LED will be On, when High-speed link starts.

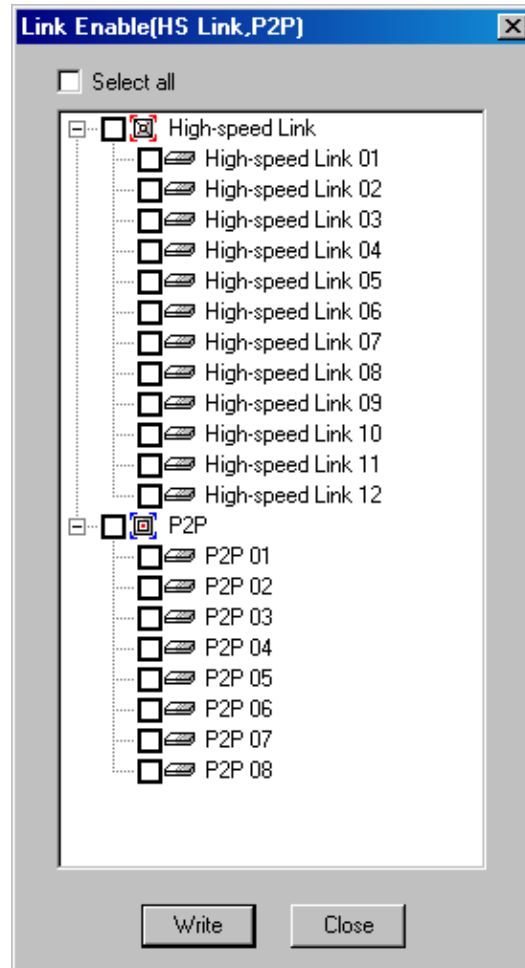

Screen of Link Enable

5.5.4 How to set GSD and downloading procedure

- 1) Download expansion I/O module and Pnet remote I/O module information through GSD file
- 2) Read the GSD file where information of our digital or analog I/O module is described through the configuration tool supporting Pnet configuration
- 3) The user can modify the parameter through configuration tool.
 - A developer should describe it in the GSD.
- 4) After completing the setting, download information to Pnet master module
- 5) Master establish communication with Pnet remote I/F module and check information of expansion I/O modules based on the downloaded information

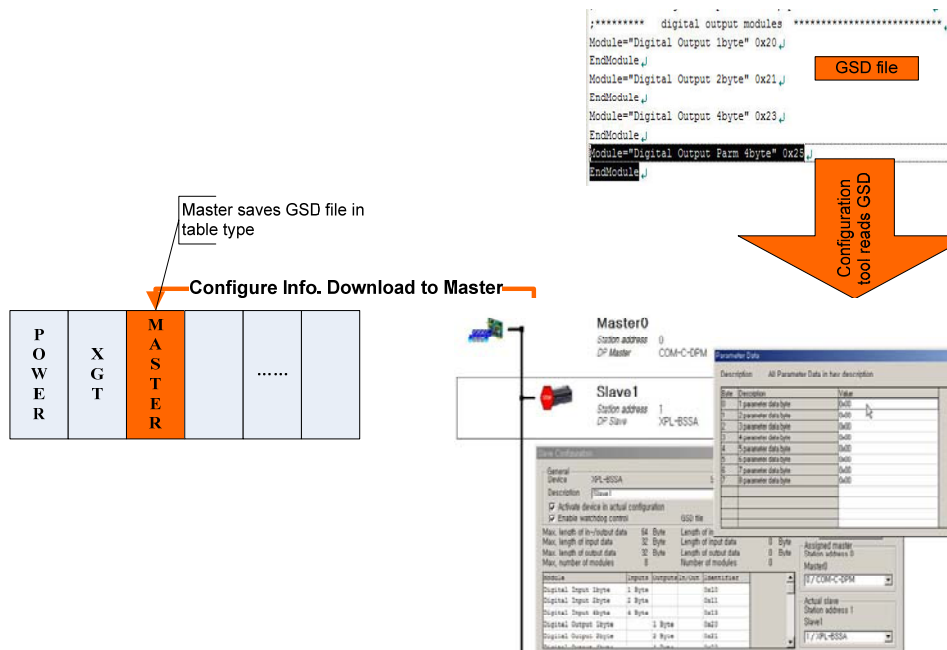

<Download GSD data to Pnet master>

Chapter 6 Installation and Wiring

6.1 Installation

6.1.1 Installation Environment

This machine has a high reliability regardless of the environment to install. But cares should be taken to secure the reliability and the safety as follows.

1) Environment Condition

- (1) Install it to a water-proof and dust-proof control panel.
- (2) Do not apply continuous impact or vibration.
- (3) Do not expose it directly to direct rays.
- (4) No dew by sudden change of temperature.
- (5) Do not exceed surrounding temperature 0~55°C.
- (6) Do not exceed relative humidity 5 ~ 95% .
- (7) No corrosive gas or combustible gas.

2) Installation Construction

- (1) When working the screw hole and the wiring, it is not allowed to put the wire remnants into the PLC.
- (2) The installation location should be the place to operate.
- (3) Do not install it on the same panel as the high voltage machine.
- (4) The distance between wiring duct and the surrounding module should be at least 50mm apart.
- (5) The grounding should be done on a good place free from noise.

3) Radiation Design of Control Panel

- (1) When installing the PLC in the sealed control panel, the radiation design should be done considering the radiation of other machine as well as the radiation of PLC itself. When circulating the air using the vent or the general fan, it may effect the PLC system due to the inflow of gas or dust.
- (2) It is recommended to install the filter or use the sealed type thermal exchanger.

6.1.2 Notices in installing Profibus-DP module

Profibus-DP Smart I/O can set max. 126 stations. (including master)

But for XGL-PSRA, station number 0~99 is available..

- (1) Check the basic factors necessary for the system configuration and select the proper communication module.
- (2) Prepare the cable and accessories such as tab, terminal resistance etc. to be used for this communication.
- (3) The station no. of all other stations including this module should be different. If connecting with double station no., it may cause the communication error.
- (4) In case of operating with normal communication, the mode switch of master module should be at RUN mode. If changing the mode switch of master module in the status that other stations are in communication, it may cause significant communication obstacle with other stations. So, special cares are needed.
- (5) For communication cable, the designated standard cable should be used. If not, it may cause significant communication obstacle.
- (6) Check if the communication cable is cut off or short-circuited before installation.
- (7) Tighten the communication cable connector completely and fix the cable connection tightly. If cable connection is not complete, it may cause significant communication obstacle.
- (8) If the communication cable is twisted or the cable is not connected properly, it may cause communication error.
- (9) In case of connecting the long distance communication cable, the wiring should be done far from the power line or inductive noise.
- (10) If LED action is abnormal, check the trouble causes referring to this manual Chapter 11. "Trouble Shooting". If the problem repeats after taking the action, contact customer service center.
- (11) Install this communication module in the status that PLC power is 'OFF'.
- (12) After finishing the communication cable connection, put the power ON and check the normal action in the LED action status. If it is normal, download the corresponding program into GMWIN for GLOFA series and into KGLWIN for MASTER-K series and run the program.

6.1.3 Notices in Handling

Here it describes notices in handling from the opening of each unit and module to the installation.

- Do not drop or apply the strong impact.
- Do not remove the PCB from the case. It may cause failure.
- Cares should be taken not to make foreign materials such as the wire remnants etc. enter the unit when wiring. If entered, remove them before applying power.

1) Notices in handling the product

Here it describes the notices in handling and installing the basic unit and the extended module.

(1) Recheck the I/O standard specification

Input part should pay attention to the input voltage and in case of output part, if applying the voltage exceeding max. capacity to Open/Close, it may cause failure, breakage and fire.

(2) Use Wire

The wire should be selected considering the ambient temperature, allowable current and the min. spec. of the wire should be more than AWG24(0.18mm²).

(3) Environment

When I/O wiring, if it is close to heat generating machine or material or if the wiring is contacted directly to oil for long time, it may cause short-circuit, breakage and failure.

(4) Polarity

Check the polarity before applying power to the terminal block that has the polarity. Special cares should be taken not to wire AC input power to DC24V external power supply terminal on the edge of basic unit input part. In case of DeviceNet, 24V power enters into the communication cable together and it is not necessary to wire separately.

(5) Wiring

- When wiring the I/O line with high voltage cable and the power cable together, induction obstacle occurs this may cause the failure and malfunction.
- It is not allowed to pass the cable in front of I/O action indication part (LED). (because it prevents from distinguishing the I/O indication.)
- In case the inductive load is connected to the output part, please connect the surge killer or diode to the load in parallel. Connect the cathode of diode to the '+' side of the power.

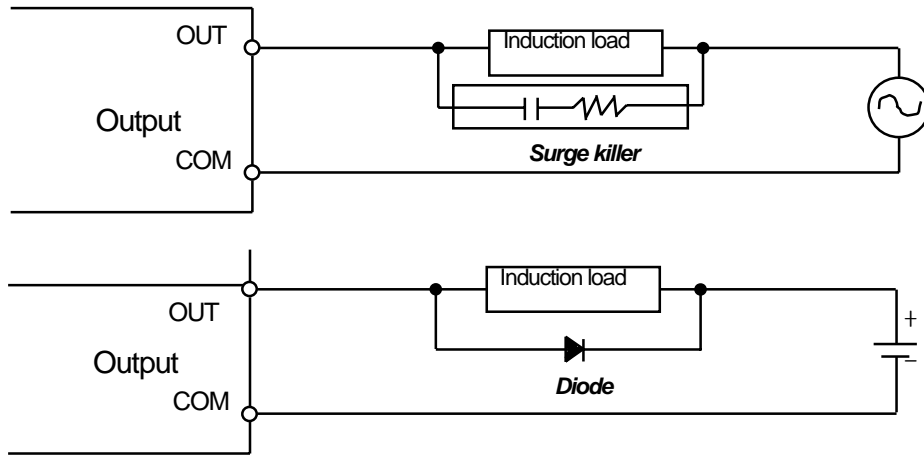

(6) Terminal block

When wiring terminal block or making screw hole, cares should be taken not to make the wire remnants enter the PLC. It may cause malfunction and failure.

(7) Except for the mentioned above, do not apply strong impact to the basic or extended unit or remove the PCB from the case.

2) Notices in installation

Here it describes the notices in attaching the PLC to the control panel.

- (1) Sufficient distance is required to have well-ventilated room and facilitate the exchange of the basic unit and the extended module. Especially, for the periodical exchange of battery (3 years), please separate the left side of the basic unit and the control panel for at least 100mm.
- (2) For the max. radiation effect, it is required to install it as shown on the figure below.

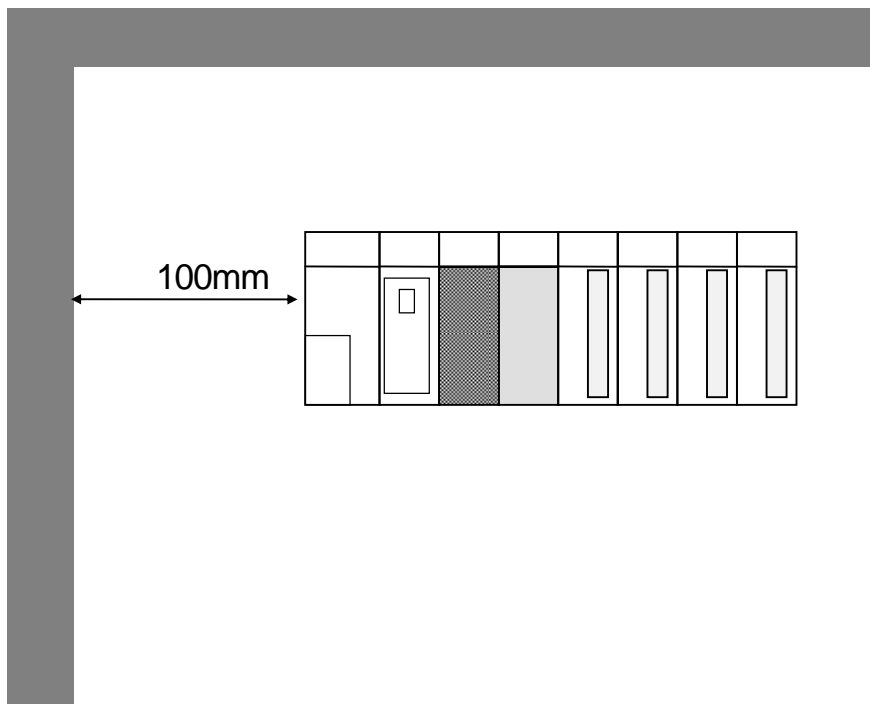

- (3) Use different panel for large sized electronic contactor or vibration source such as no-fuse breaker etc. and install separately.
- (4) Install the duct for wiring if necessary.
But, if the dimension of upper part or lower part of PLC is smaller than the figure below, please pay attention to the following.
 - In case of installing on the upper PLC, the height of wiring duct should be less than 50mm for good ventilation.
 - In case of installing on the lower PLC, please consider minimum radius of the cable.

Chapter 6 Installation and Wiring

(5) In case the equipment is installed in front of the PLC (inside the door) to avoid the effect of radiant noise or the heat, it is required to separate it more than 100mm and be install.

And the left/right direction of the unit and the equipment should be separated more than 100mm and installed.

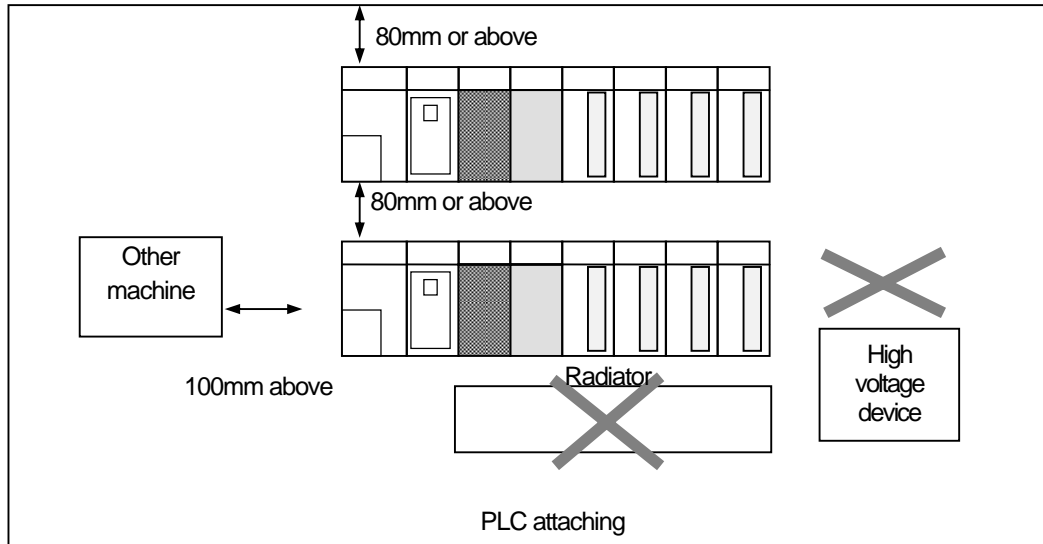

6.2 Wiring

Describes the notices related to the wiring in case of using the system

6.2.1 Power Wiring

- 1) For power, please use DC 24V power supply.
- 2) If the power variation is larger than the regular range, please connect a constant voltage transformer.
- 3) In order to prevent the noise from the power cable, it is required to twist the power cable densely if possible, and connect within the shortest distance.

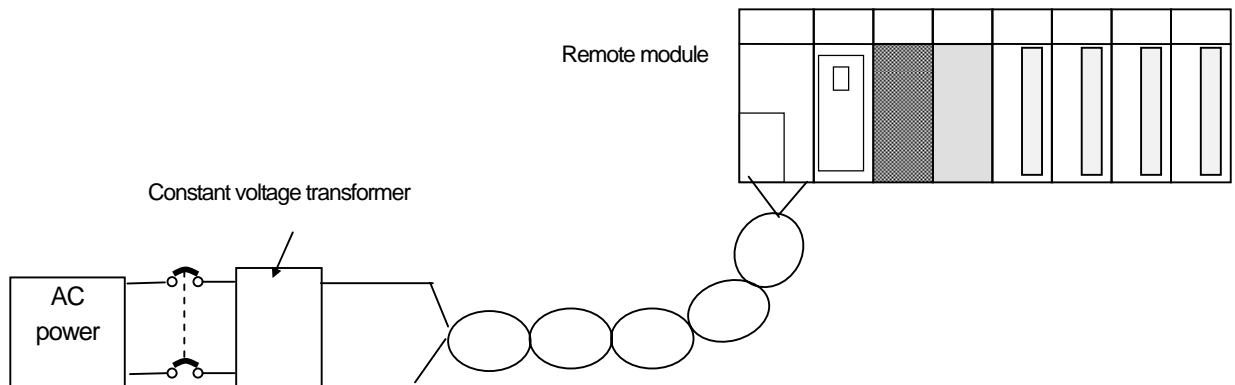

- 4) Connect power of which the noise between lines or between grounds is small.
(If there is much noise, please connect the insulation transformer.)

- 5) For PLC power, I/O machine and power machine, it is required to divide the system as follows.

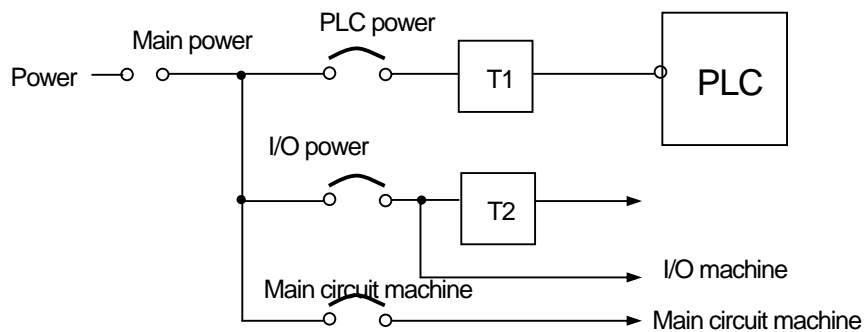

※ T1,T2: Constant voltage transformer

Chapter 6 Installation and Wiring

- 6) For the power cable, it is required to use a thick one (2mm^2) to make the small falling down of the voltage.
- 7) The power DC24V cable is not allowed to approach closely to the main circuit (high voltage, convection current) cable, I/O signal cable and needs to separate more than 80mm apart.
- 8) Please use the surge absorber to prevent the lightning as shown on the below.

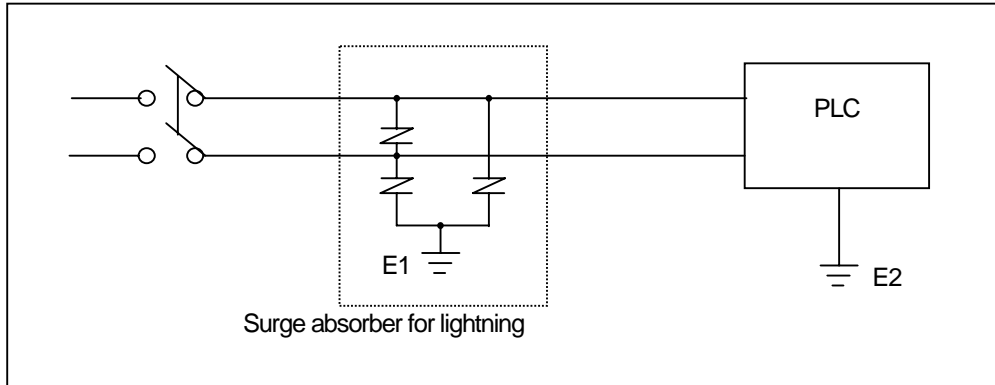

Remark

- 1) Separate the earth (E1) of the surge absorber for lightning and the earth (E2) of PLC.
- 2) Select the surge absorber for lightning so that it does not exceed max. allowable voltage of the absorber even when the power voltage is rising maximum.

- 9) When you are afraid of the invasion of the noise, please use the insulation sealed transformer or the noise filter.
- 10) In case of the wiring of each input resource, the wiring of the sealed transformer or the wiring of the noise filter is not allowed to pass the duct.

6.2.2 I/O Device Wiring

- 1) The spec. of I/O wiring cable is 0.18~2 mm² and it is recommended to use the cable spec. (0.5mm²) conveniently.
- 2) Input cable and output cable should be separated for wiring.
- 3) I/O signal cable should be separated at least 80mm from main circuit cable of high voltage, high current when wiring.
- 4) In case it is not available to separate the main circuit cable and the power cable, please use the shielded cable and earth the PLC.

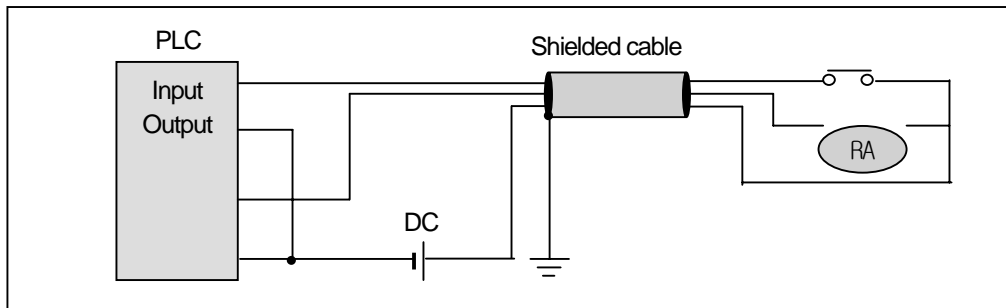

- 5) In case of pipe wiring, make sure of the pipe and then ground it.
- 6) DC24V output cable should be separated from AC110V cable and AC220V cable.
- 7) In case of wiring the long distance more than 200m, the error occurs according to the leakage current caused by the interline capacity.

6.2.3 Grounding Wiring

- 1) As this PLC carries out sufficient noise policy, it is available to use without grounding except the case where there is much noise. But, when grounding, please refer to the following notices.
- 2) When grounding, please use the exclusive grounding if possible.
For the grounding construction, please use the 3rd class grounding (grounding resistance less than 80 Ω).
- 3) If not available to use the exclusive grounding, please use the common grounding as shown on the figure (B).

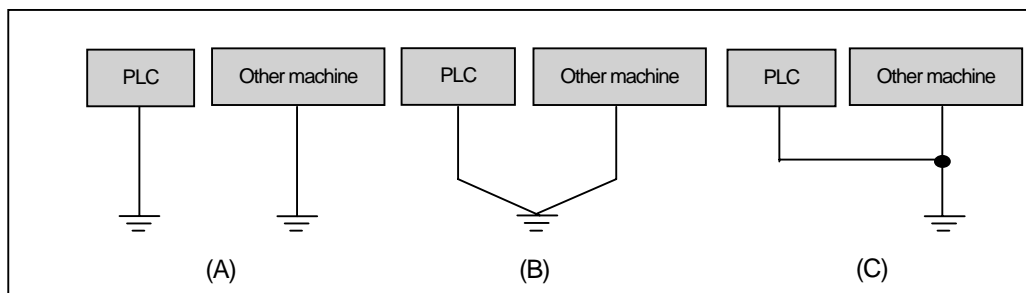

(A) exclusive grounding: Excellent (B) common grounding: Good (C) common grounding : Bad

Chapter 6 Installation and Wiring

- 4) Please use the electric wire for grounding more than 2 mm². Place the grounding point near this PLC if possible and shorten the length of the grounding cable.
- ▶ When connecting the extended base, please connect the extended connector accurately.
 - ▶ Do not remove the PCB from the module case and modify the module.
 - ▶ When attaching/removing the module, the power should be OFF.
 - ▶ Use the cellular phone or radio phone apart more than 30mm from the product.
 - ▶ I/O signal cable and communication cable should be at least 10cm apart from the high voltage cable or the power cable to avoid the effect caused by the noise or the change of magnetic field.

6.2.4 Cable Specification for Wiring

The Cable specification to be used for the wiring is as follows

External connection type	Cable spec.(mm ²)	
	Low limit	High limit
Digital input	0.18 (AWG24)	1.5 (AWG16)
Digital output	0.18 (AWG24)	2.0 (AWG14)
Analog I/O	0.18 (AWG24)	1.5 (AWG16)
Communication	0.18 (AWG24)	1.5 (AWG16)
Main power resource	1.5 (AWG16)	2.5 (AWG12)
Protection grounding	1.5 (AWG16)	2.5 (AWG12)

For the power and I/O wiring for Smart I/O, it is required to use the compressed terminal.

- Use 'M3' type screw for the terminal.
- Tighten the terminal screw with 6 ~ 9 kg·cm torque.
- Use the fork type screw for the compressed terminal.

Example of the proper compressed terminal (fork type)

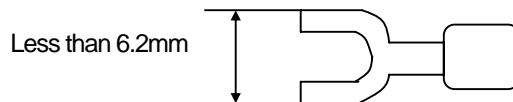

Chapter 7 Maintenance and Repair

To maintain the PLC in optimal status, please carry out daily check and regular check.

7.1 Repair and Check

I/O module is usually composed of semiconductor microelectronic device and the life is semi- permanent. As the microelectronic device may occur the error caused by the ambient environment, it is required to check it periodically. The following are items to be checked 1~2 times every 6 months.

Check items		Judgment basis	Action
Ambient environment	Temperature	0 ~ +55°C	Control the use temperature and the use humidity.
	Humidity	5 ~ 95%RH	
	Vibration	No vibration	Use the dust-proof rubber or take the vibration protection policy.
Shaking of each unit and module		No shake	Make all unit and module not to be shaker
Terminal screw loosened.		No loosening	Tighten the loosened screw.
Input voltage change rate		Within -15%/+10%	Maintain the change rate within the allowable range.
Spare parts		Check if the quantity of spare part and the preservation status is good.	Make up insufficient and improve the preservation status.

7.2 Daily Check

Daily check point for Pnet remote I/F module is as follows.

1) Daily check for Profibus-DP module

Checking items		Description	Judgment basis	Action
Cable connection status		Cable loosening	No loosening	Tighten the cable
Module connection status		Screw loosening	No loosening	Tighten the module screw.
Indication LED	RUN LED	Check 'ON'	Module operates normally (normal operation of system OS)	Refer to Chapter 3.
	P-N LED	Check 'ON'	Power and communication normal	Refer to Chapter 3.
	STATUS LED	Check 'ON'	Expansion I/O module information match	Refer to Chapter 3.
	ERR LED	Check 'ON'	Module detached, invalid module installed, Out of I/O data range, I/O parameter error	Refer to Chapter 3.

7.3 Regular Check

Check the following items 1~2 times every 6 months and take the necessary actions.

Checking items		Checking method	Judgment basis	Action
Ambient environment	Temperature	Measure by thermometer/hygrometer.	0 ~ 55°C	Adjust suitable for general standard (in case of using in the area, apply the environment basis in the area)
	Humidity		5 ~ 95%RH	
	Pollution	Measure the corrosive gas.	No corrosive gas	
Module status	Loosening, shaking	Shake the communication module.	Tightening status	Tighten the screw.
	Dust, foreign material adding	Macrography	No adding	
Connection status	Terminal screw loosened	Tightening by the driver	No loosening	Tightening
	Pressed terminal approach	Macrography	Proper interval	Correction
	Connector loosened.	Macrography	No loosening	Connector correction Screw tightening
Power voltage check		Voltage measure between terminals	DC 20.4 ~ 28.8V	Power supply change

Chapter 8 Trouble Shooting

Here it describes the contents of each error to be occurred while operating the system, the method to find the cause and the action.

8.1 Basic Procedure of Trouble Shooting

It is important to use high reliable machine to increase the system reliability but it is important to take prompt action when trouble occurs as well.

To start the system promptly, it is more important to find the trouble occurring cause promptly and take the necessary action. The basic items to comply when taking this trouble shooting are as follows.

1) Check with the naked eye

Check the following items with the naked eye.

- Machine action status (stop, action)
- Power appliance status
- I/O machine status
- Wiring status (I/O cable, extended or communication cable)
- Check the indication status of each indicator (RUN, ERR, P-RUN, STATUS LED, I/O LED etc.) and connect the peripheral device and then check the PLC action status or the program contents.

2) Check the trouble

Examine how the trouble is changed by the following action.

- Connect or disconnect. communication cable

3) Limit range

Estimate the cause of trouble using the above method.

- Is it the cause from PLC itself? Or external cause?
- Is it the cause from I/O part? Or other cause?
- Is it the cause from PLC program?

8.2 Trouble Shooting

Here it describes the trouble finding method, the error code and the actions on the above by dividing them per phenomenon.

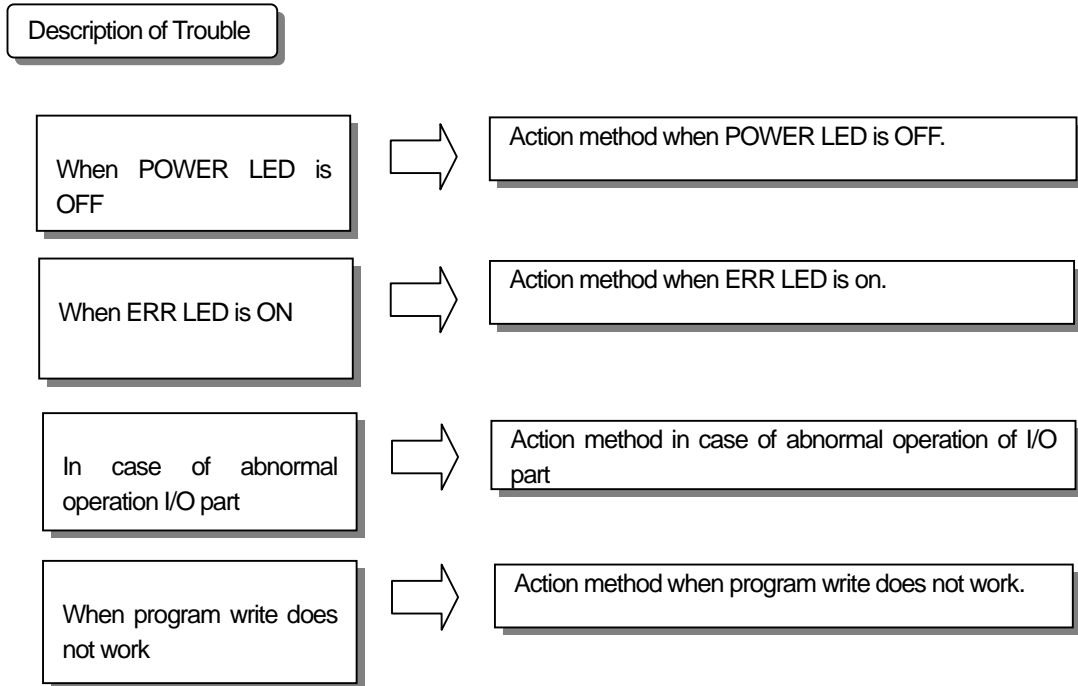

8.2.1 Action method when RUN LED is OFF

Here it describes the action order when RUN LED is OFF while applying the power or during the operation.

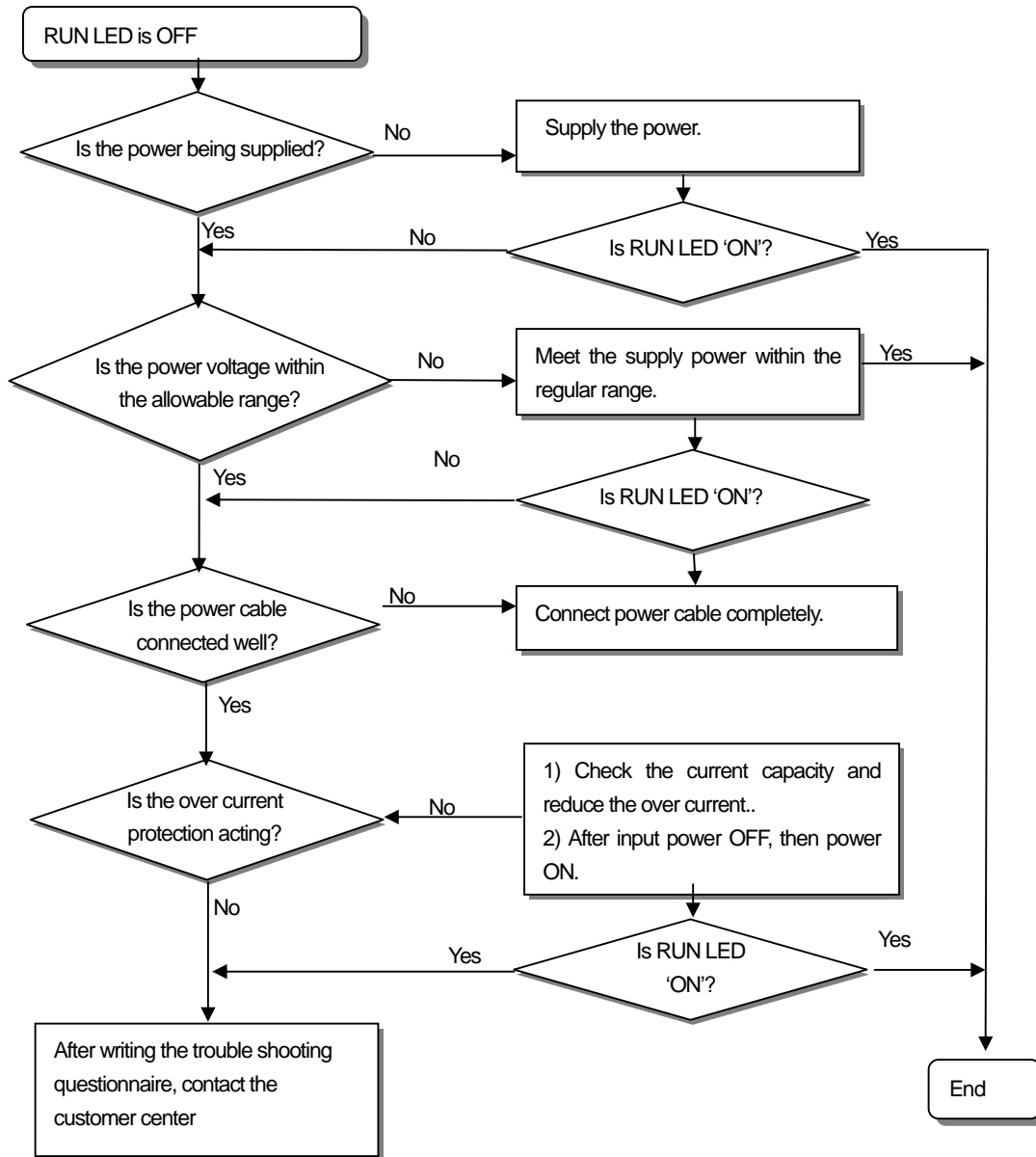

8.2.2 Action method when ERR LED is ON

Here it describes the action order when ERR LED is on in case of power input, or when operation starts, or during operation.

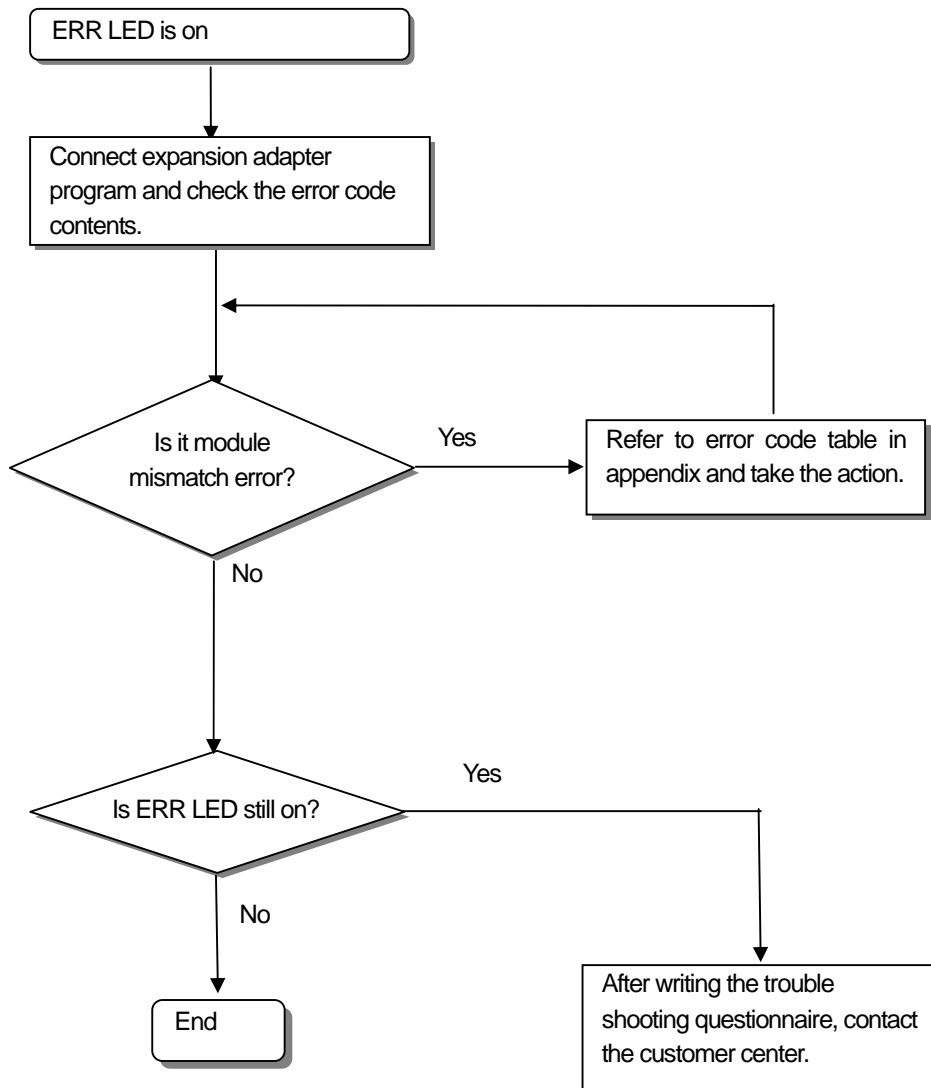

8.2.3 Action method when I/O part does not work normally.

Here it describes the action order when I/O part does not work normally during operation, as shown on the program example below.

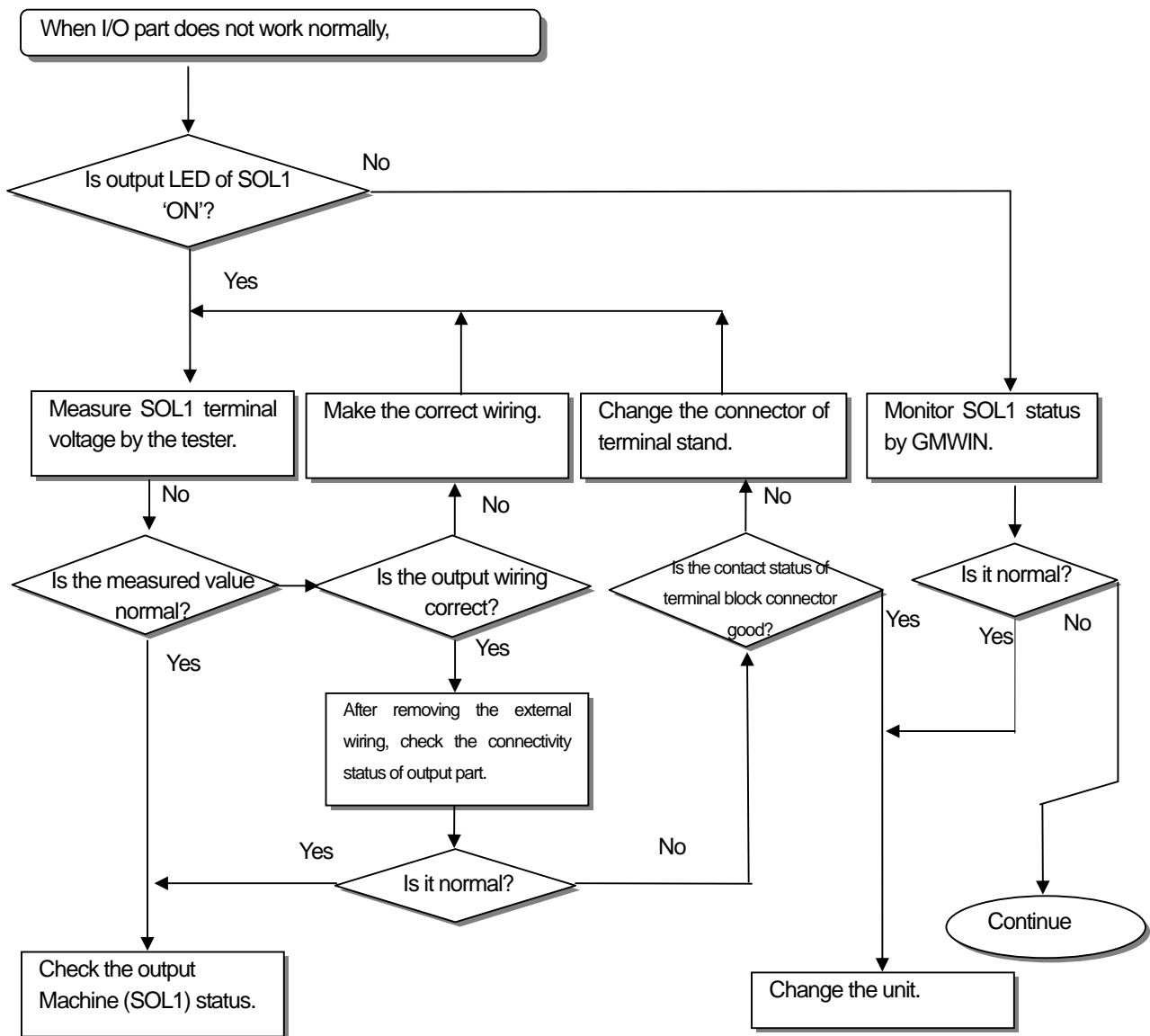
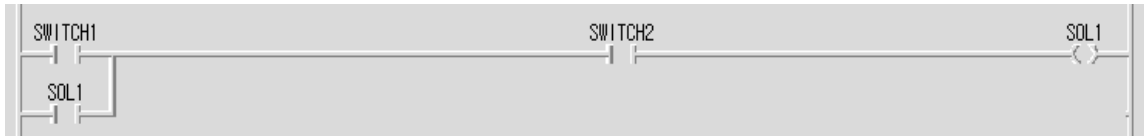

Chapter 8 Trouble Shooting

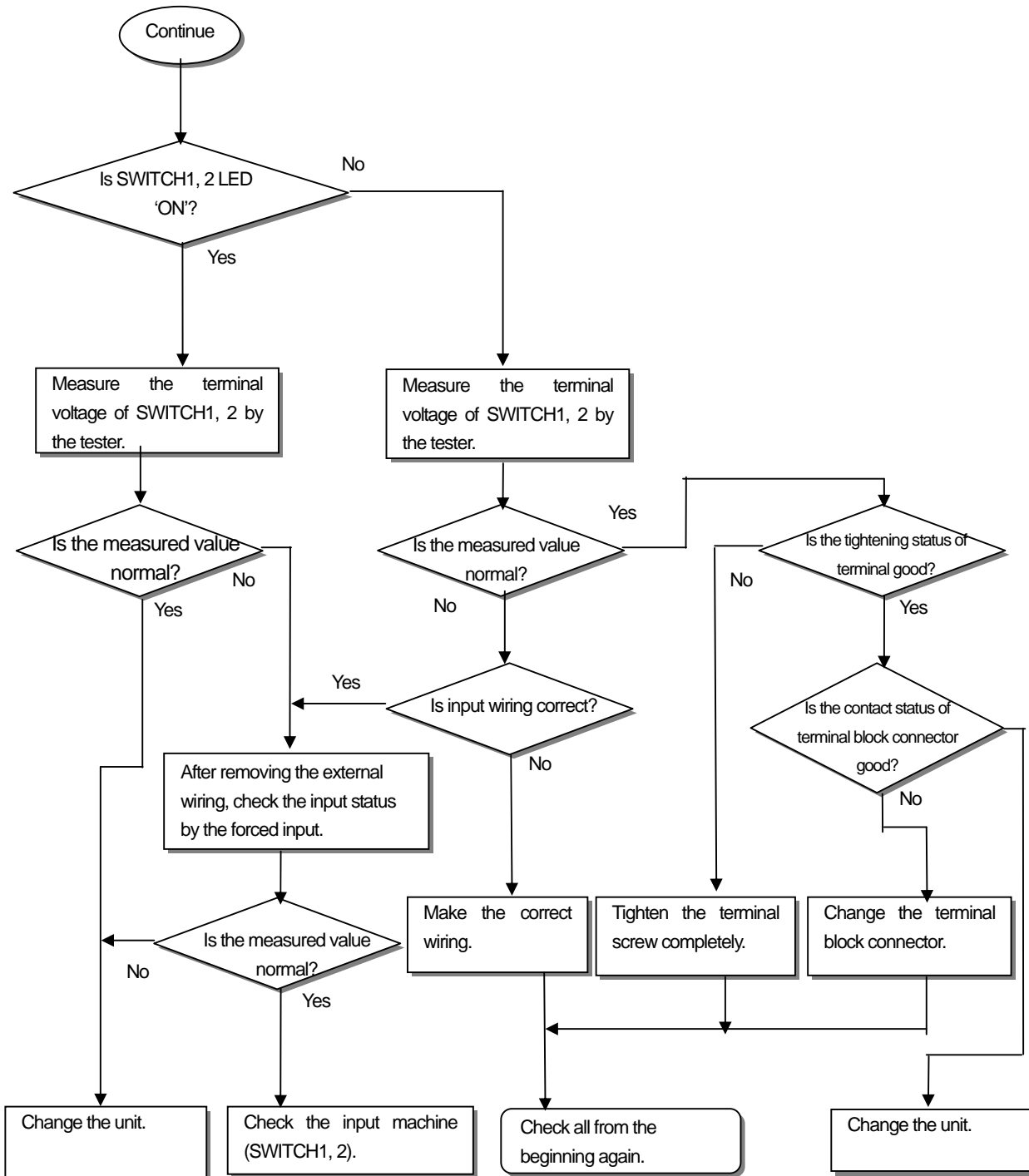

8.2.4 Action method when Program Write does not work

Here it describes the action order when Program write does not work in the Master CPU.

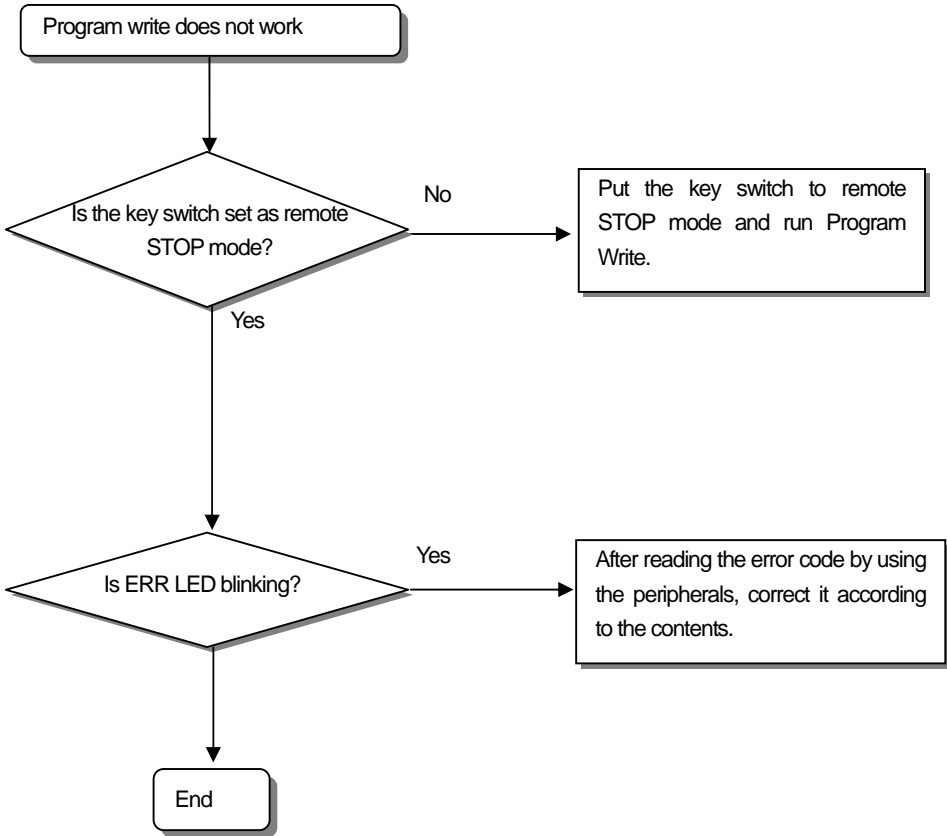

8.2.5 SyCon connection error

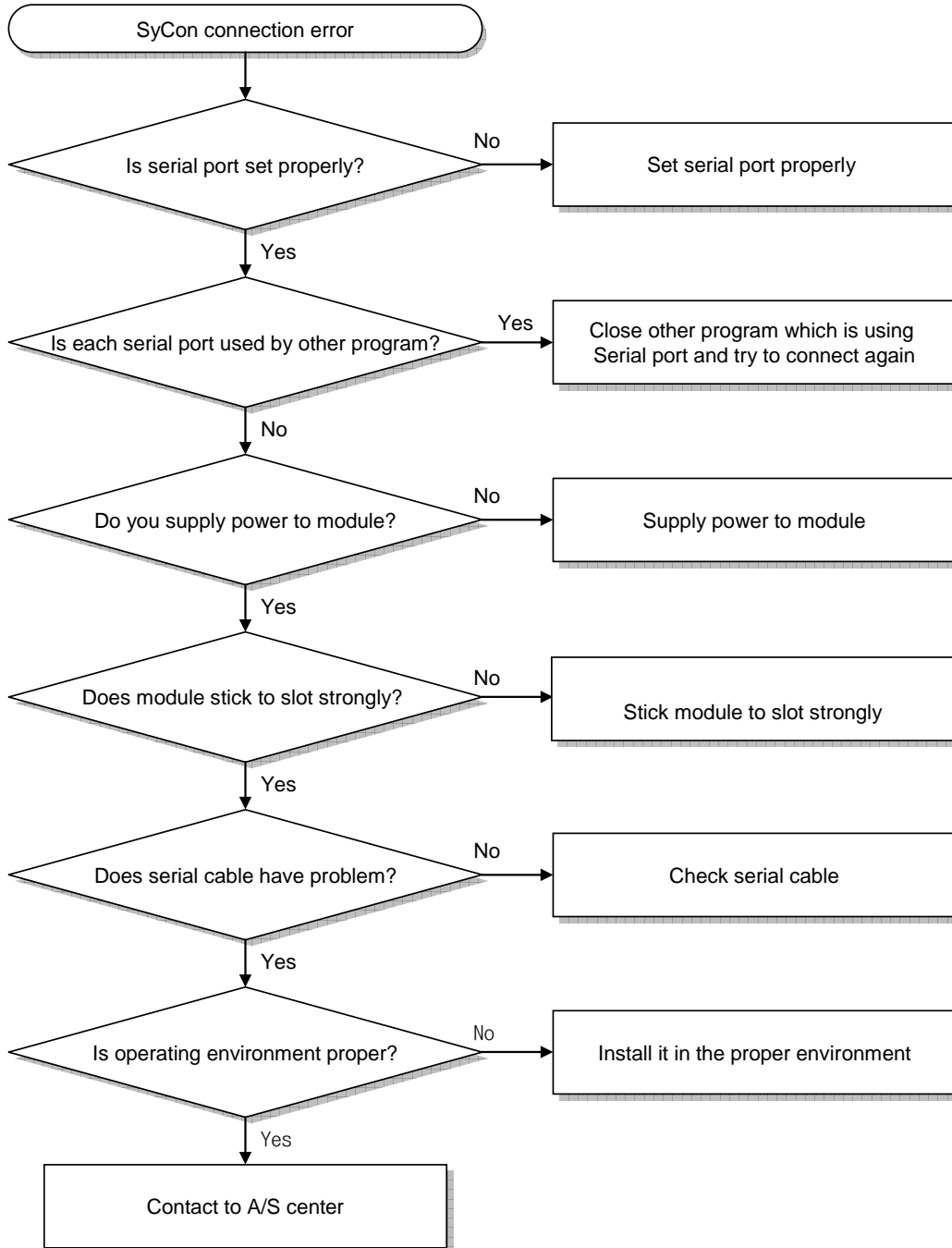

8.2.6 XG-PD connection error

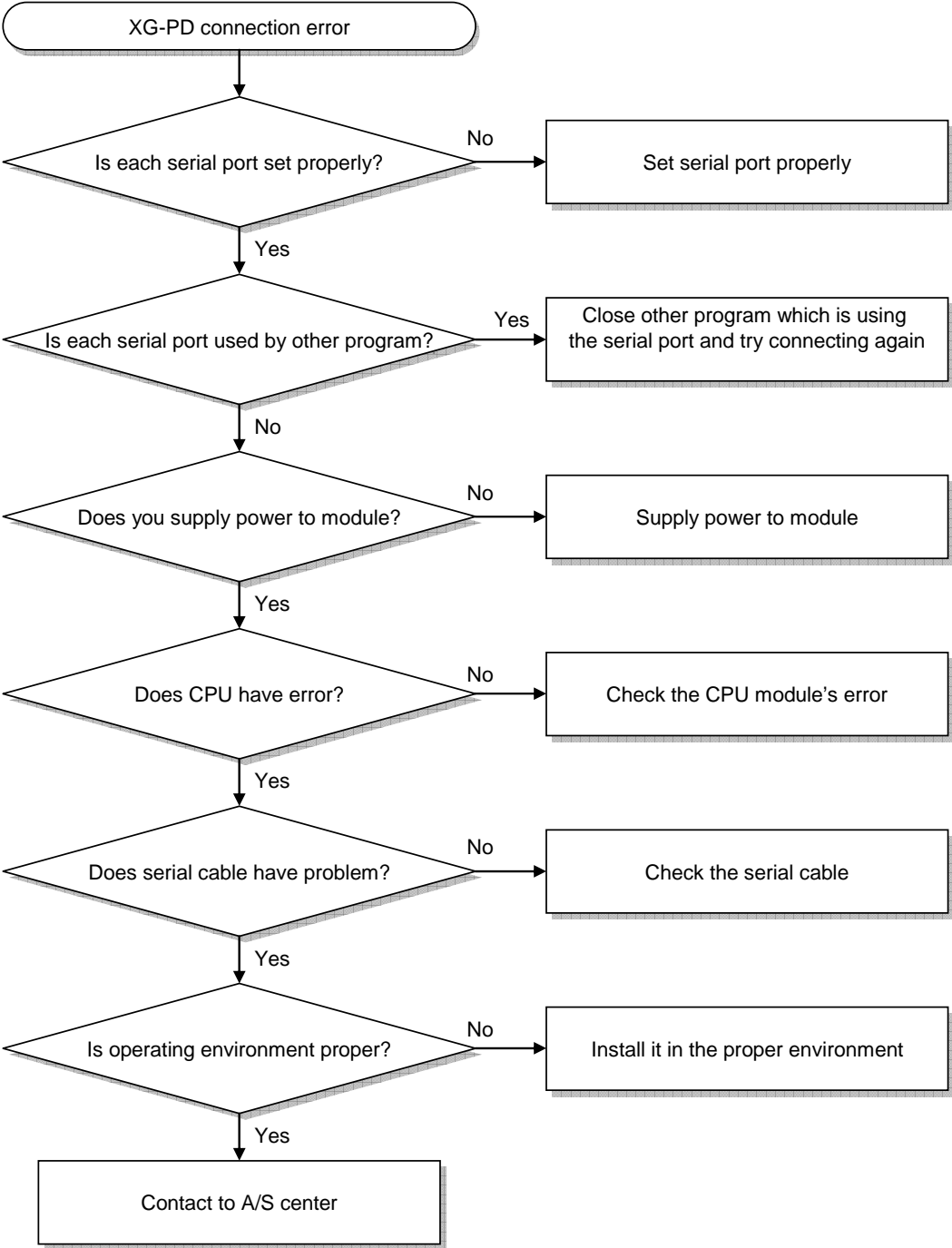

8.2.7 Communication error with slave

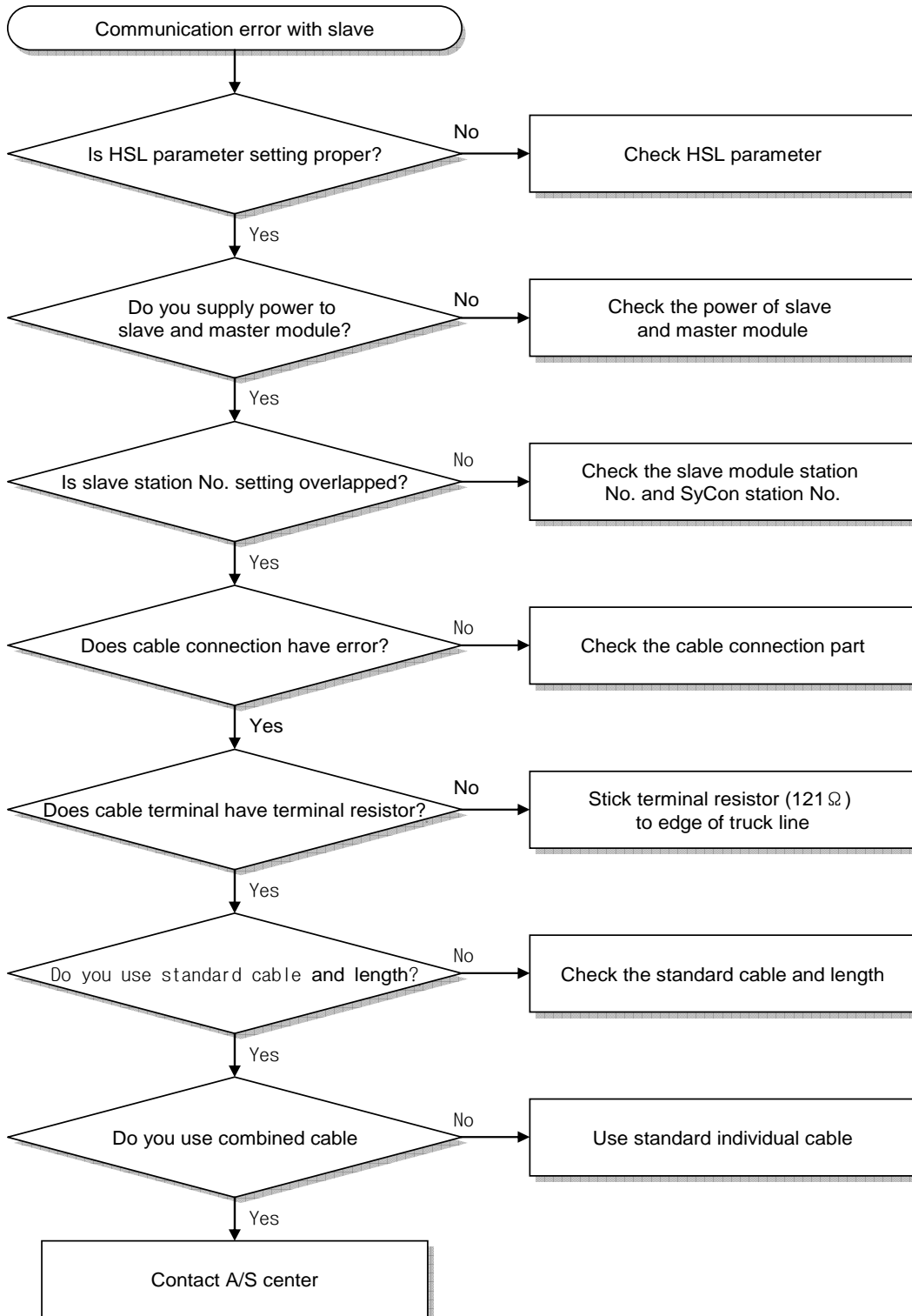

8.2.8 Analog Module's Channel Error Diagnosis Function

- 1) Pnet remote I/F module can check the internal address or U device area of special module and diagnose error status by using Refresh access function of BPMC after processing I/O data.
- 2) For our analog I/O module, it can detect the disconnection information and error type of analog I/O module
- 3) If it finds the error, it sends the special frame (refer to S/W detailed design) for diagnosis to master.
- 4) In diagnosis process, in case Diagnosis Request frame of master occurs, it creates the frame based on standard diagnosis frame structure and sends it to master.

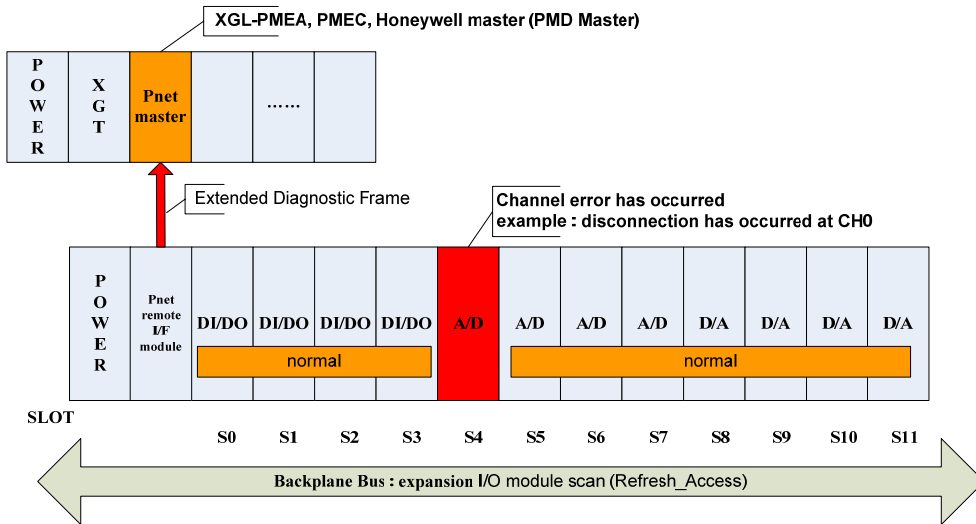

5) Example of diagnosis when disconnection occurs at CH7, 8 of AV8A analog input module installed at 6th slot during data communication. (Channel diagnosis is supported at XGL-PMEC and PROFICON)

(1) To check diagnosis status information, go into DEBUG mode.

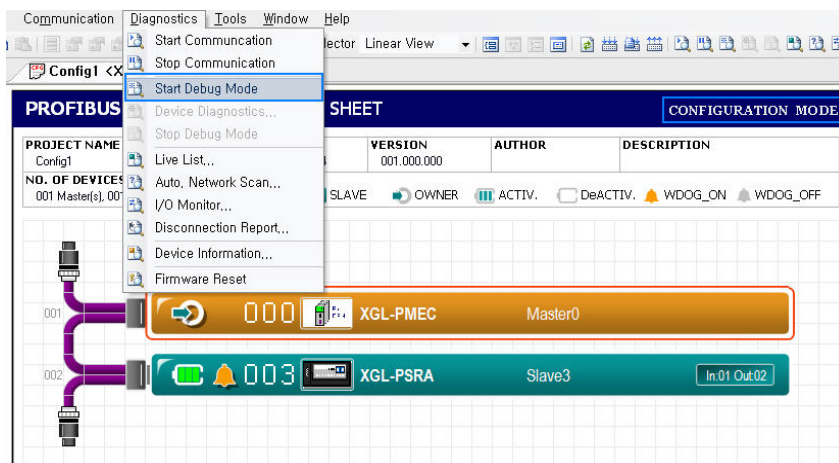

Chapter 8 Trouble Shooting

- (2) You can check the DEBUG mode status at right-top of screen. If here is no error information on analog input module channel of expansion base, no message appears at XGL-PSRA. This means normal communication status

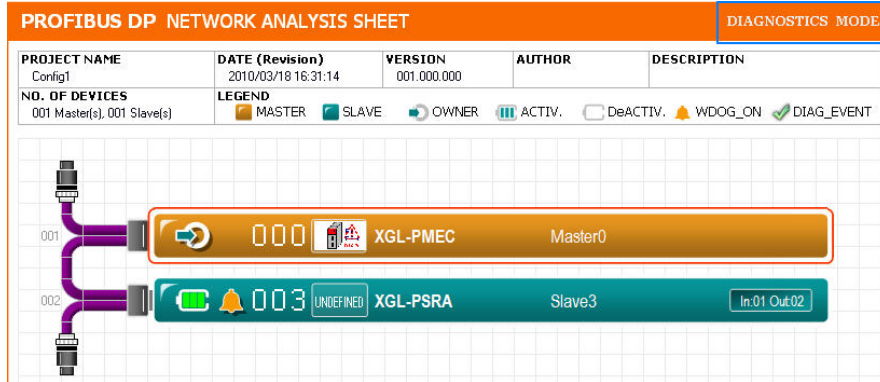

- (3) If disconnection occurs at CH7, 8 of AV8A analog input module installed at 6th slot, icon "DIAG" flickers at PSRA

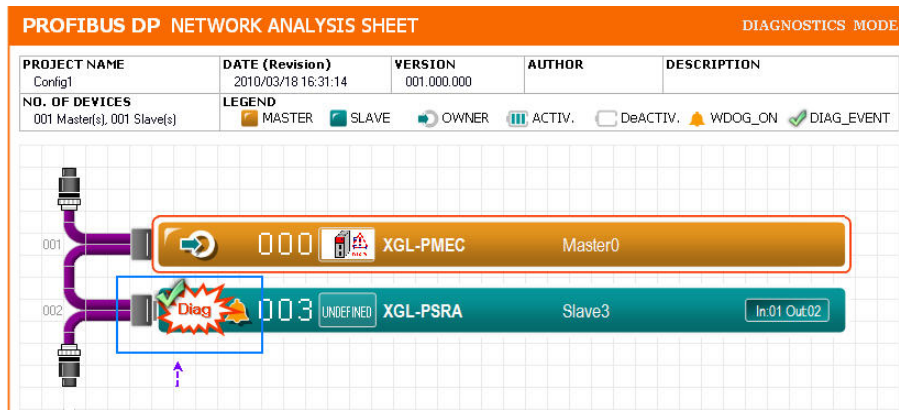

(4) For detailed channel diagnosis message, double-click PSRA. Then, diagnosis data related with channel appears. This data is displayed in accordance with protocol of standard Pnet diagnosis code.

The screenshot shows the 'PROFIBUS DP NETWORK ANALYSIS SHEET' in 'DIAGNOSTICS MODE'. The network diagram displays two devices: Master0 (XGL-PMEC) and Slave3 (XGL-PSRA). Slave3 has a 'Diag' icon and a status of 'UNDEFINED'. The 'Device Diagnostic' window is open, showing the following information:

Current Slave Device
 Ident. No.: 0x07b8, Slave Name: (Add:003) XGL-PSRA, Assigned Master Name: (Add:000) XGL-PMEC

Diagnostic Information

Device Status1	Device Status2	Device Status3
<input type="checkbox"/> Slave is locked from another master	<input type="checkbox"/> Slave is deactivated in master parameter set	<input type="checkbox"/> Data overflow
<input type="checkbox"/> Parameter fault	<input type="checkbox"/> Reserved	<input type="checkbox"/> Reserved1
<input type="checkbox"/> Invalid slave response	<input type="checkbox"/> Slave is in SYNC mode	<input type="checkbox"/> Reserved2
<input type="checkbox"/> Slave doesn't support requested parameter function	<input type="checkbox"/> Slave is in FREEZE mode	<input type="checkbox"/> Reserved3
<input type="checkbox"/> Slave has extended diag data to report an error	<input checked="" type="checkbox"/> Response monitoring / Watchdog On	<input type="checkbox"/> Reserved4
<input type="checkbox"/> Config fault	<input checked="" type="checkbox"/> (Always set to 1)	<input type="checkbox"/> Reserved5
<input type="checkbox"/> Station not ready for data exchange	<input type="checkbox"/> Static diagnostic	<input type="checkbox"/> Reserved6
<input type="checkbox"/> Station not existent	<input type="checkbox"/> Slave must be parameterized	<input type="checkbox"/> Reserved7

Ident. Number : 0x07B8 / Assigned Master Address : 0

Extended Diagnostic Information

Device Related Data (Hex)	Module Related Data (Hex)	Channel Related Data (Hex)
Byte 0: 00+	Byte 0: 00+	Byte 0: 85
Byte 1: 01	Byte 1: 01	Byte 1: 47
Byte 2: 02	Byte 2: 02	Byte 2: B0
Byte 3: 03	Byte 3: 03	Byte 3: 85
Byte 4: 04	Byte 4: 04	Byte 4: 48
Byte 5: 05	Byte 5: 05	Byte 5: B0
Byte 6: 06	Byte 6: 06	Byte 6: 00
Byte 7: 07	Byte 7: 07	Byte 7: 00
Byte 8: 08	Byte 8: 08	Byte 8: 00
Byte 9: 09	Byte 9: 09	Byte 9: 00
Byte 10: 10+	Byte 10: 10+	Byte 10: 00
Byte 20: 20+	Byte 20: 20+	Byte 20: 00
Byte 30: 30+	Byte 30: 30+	Byte 30: 00
Byte 40: 40+	Byte 40: 40+	Byte 40: 00
Byte 50: 50+	Byte 50: 50+	Byte 50: 00
Byte 60: 60+	Byte 60: 60+	Byte 60: 00

Extended Diagnostic Data Interpretation Using GSD

Position	Data Group	Byte	Bit	Binary	Decimal	Item	Description
1	Channel Related Data	00	0	1	5	Module Identifier	Reporting identifier(module) number
2			1	0			
3			2	1			
4			3	0			
5			4	0			
6			5	0			
7			6	0	2	Header Identifier	This is module related diagnosis header
8			7	1			
9	Channel Related Data	01	0	1	7	Reporting Channel number	Reporting channel number is 7
10			1	1			

(5) Since one channel has 3 byte size, in the above case, it means error occurs at two channels. In the following information, meaning of the code is displayed in accordance with Pnet protocol standard.

The screenshot shows the 'Extended Diagnostic Information' window with the following data:

Device Related Data (Hex)	Module Related Data (Hex)	Channel Related Data (Hex)
Byte 0: 00+	Byte 0: 00+	Byte 0: 85
Byte 1: 01	Byte 1: 01	Byte 1: 47
Byte 2: 02	Byte 2: 02	Byte 2: B0
Byte 3: 03	Byte 3: 03	Byte 3: 85
Byte 4: 04	Byte 4: 04	Byte 4: 48
Byte 5: 05	Byte 5: 05	Byte 5: B0
Byte 6: 06	Byte 6: 06	Byte 6: 00
Byte 7: 07	Byte 7: 07	Byte 7: 00
Byte 8: 08	Byte 8: 08	Byte 8: 00
Byte 9: 09	Byte 9: 09	Byte 9: 00
Byte 10: 10+	Byte 10: 10+	Byte 10: 00
Byte 20: 20+	Byte 20: 20+	Byte 20: 00
Byte 30: 30+	Byte 30: 30+	Byte 30: 00
Byte 40: 40+	Byte 40: 40+	Byte 40: 00
Byte 50: 50+	Byte 50: 50+	Byte 50: 00
Byte 60: 60+	Byte 60: 60+	Byte 60: 00

Extended Diagnostic Data Interpretation Using GSD

Position	Data Group	Byte	Bit	Binary	Decimal	Item	Description
1	Channel Related Data	00	0	1	5	Module Identifier	Reporting identifier(module) number
2			1	0			
3			2	1			
4			3	0			
5			4	0			
6			5	0			
7			6	0	2	Header Identifier	This is module related diagnosis header
8			7	1			
9	Channel Related Data	01	0	1	7	Reporting Channel number	Reporting channel number is 7
10			1	1			

Chapter 8 Trouble Shooting

6) Limit on channel diagnosis

- (1) For channel diagnosis, up to 20 are supported simultaneously. If diagnosis more than 20 occurs, the recently occurred diagnosis message is displayed first. But in case of module detachment error (while Hot-Swap switch is not on), up to 19 channel diagnosis message are supported.
- (2) The modules supporting channel diagnosis are as follows. And diagnosis function is supported when input current and voltage range are as follows. You can set this when writing parameter on analog input module through USB.
 - XGF-AD4S, XGF-AV8A, XGF-AC8A, XGF-AD16A
 - Input current and voltage range: 1 ~ 5V, 4 ~ 20mA

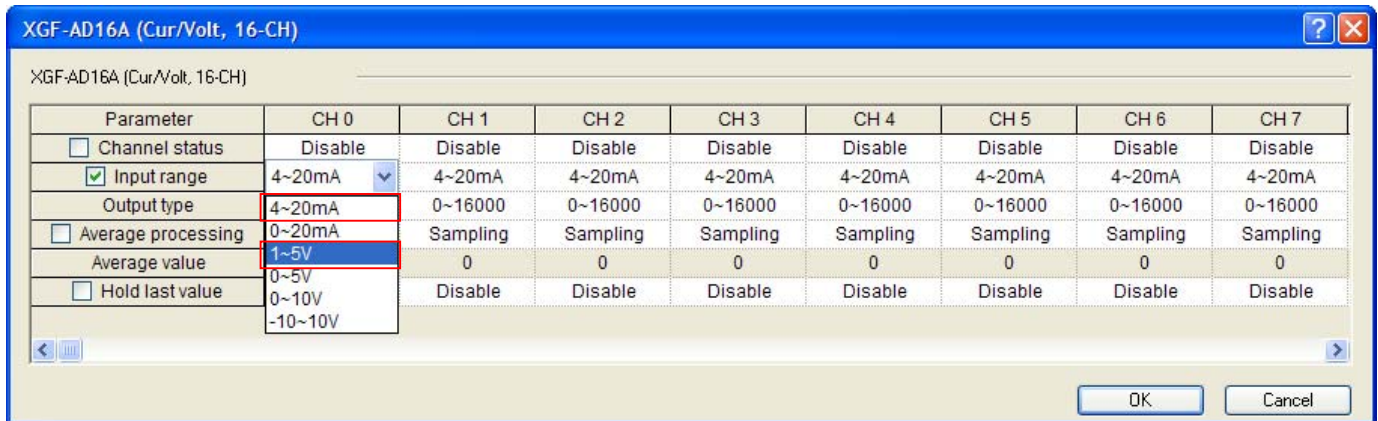

7) Cancel diagnosis status

- (1) If you check the channel where "Diag" status occurs and solve the problem, "Diag" icon disappears at PROFICON diagnosis mode. And executes data communication.



8) Report module detachment status

- (1) If module is detached while module change switch is not on, PSRA reports this to master with diagnosis message. At this time, if channel diagnosis occurs simultaneously, channel diagnosis information is displayed together. In case of module detachment error, you should reset PSRA for normal operation. If module is detached while module change switch is on, diagnosis message doesn't appear and normal data communication is executed.
- (2) When module detachment and channel diagnosis occur simultaneously
When module in 12th slot is detached and disconnection occurs at CH8 of 6th AV8A, diagnosis mode of PROFICON displays all two information. But it can't return to data communication mode. For return, you should reset PSRA.

The screenshot displays a diagnostic interface with several panels:

- Diagnostic Information:** A list of error messages such as "Slave is locked from another master", "Parameter fault", and "Data overflow".
- Extended Diagnostic Information:** Three hex data grids for "Device Related Data", "Module Related Data", and "Channel Related Data".
- Extended Diagnostic Data Interpretation Using GSD:** A table mapping data groups to bit positions and their meanings.
- Network Analysis Sheet:** A sidebar showing project details and a physical network diagram with modules like "XGL-PMEC" and "XGL-PSRA".

Module detachment message appears with channel disconnection information as figure above

9) PROFIBUS standard diagnosis protocol

Here it describes Pnet standard channel diagnosis code with example where disconnection occurs at CH7 of AV8A. Allocating 3 byte channel diagnosis code per channel is regulation in standard. Each byte has the following meaning.

This screenshot provides a detailed view of the diagnostic data interpretation table. Annotations include red boxes around specific values and blue arrows pointing to their descriptions:

Position	Data Group	Byte	Bit	Binary	Decimal	Item	Description	
1	Channel Related Data	00	0	1	5	Module Identifier	Reporting identifier(module) number	
2			1	0				
3			2	1				
4			3	0				
5			4	0				
6			5	0				
7			6	0				
8			7	1		2	Header Identifier	This is module realted diagnosis header
9	Channel Related Data	01	0	0	8	Reporting Channel number	Reporting channel number is 8	
10			1	0				

Annotations in the image:

- Red boxes highlight the decimal values 5 and 2.
- Blue arrows point from the description of the decimal value 5 to the text: "Means disconnection occurred at 6th slot analog input module Corresponding to 8, it means upper two bits are 11 This is header meaning this diagnostic information is channel related information".
- A blue arrow points from the description of the decimal value 2 to the text: "This is module realted diagnosis header".

Chapter 8 Trouble Shooting

Extended Diagnostic Information

Device Related Data (Hex)										Module Related Data (Hex)										Channel Related Data (Hex)													
Byte	0	1	2	3	4	5	6	7	8	9	Byte	0	1	2	3	4	5	6	7	8	9	Byte	0	1	2	3	4	5	6	7	8	9	
00+	█										00+	█											00+	85	48	B0							
10+											10+												10+										
20+											20+												20+										
30+											30+												30+										
40+											40+												40+										
50+											50+												50+										
60+											60+												60+										

Position	Data Group		Byte	Bit	Value		Extended Diagnostic Data Interpretation Using GSD	
	Binary	Decimal			Item	Description		
9	Channel Related Data	01	0	0	8	Reporting Channel number	Reporting channel number is 8	
10			1	0				
11			2	0				
12			3	1				
13			4	0				
14			5	0				
15			6	1	1	Channel I/O Type	Input	
16			7	0				

Means diagnostic information occurred.

Means it is analog input module

Extended Diagnostic Information

Device Related Data (Hex)										Module Related Data (Hex)										Channel Related Data (Hex)													
Byte	0	1	2	3	4	5	6	7	8	9	Byte	0	1	2	3	4	5	6	7	8	9	Byte	0	1	2	3	4	5	6	7	8	9	
00+	█										00+	█											00+	85	48	B0							
10+											10+												10+										
20+											20+												20+										
30+											30+												30+										
40+											40+												40+										
50+											50+												50+										
60+											60+												60+										

Position	Data Group		Byte	Bit	Value		Extended Diagnostic Data Interpretation Using GSD	
	Binary	Decimal			Item	Description		
17	Channel Related Data	02	0	0	16	Error Type	Channel disconnection string message	
18			1	0				
19			2	0				
20			3	0				
21			4	1				
22			5	1	5	Channel Type	Word	
23			6	0				
24			7	1			Means one channel is 1 word	

If several channel diagnosis occurs, 3 byte diagnostic information as many as channel diagnosis count appear. The following is case disconnection appears at CH6, 7, 8 of 6th slot analog input module.

Extended Diagnostic Information

Device Related Data (Hex)										Module Related Data (Hex)										Channel Related Data (Hex)													
Byte	0	1	2	3	4	5	6	7	8	9	Byte	0	1	2	3	4	5	6	7	8	9	Byte	0	1	2	3	4	5	6	7	8	9	
00+	█										00+	█											00+	85	46	B0	85	47	B0	85	48	B0	
10+											10+												10+										
20+											20+												20+										
30+											30+												30+										
40+											40+												40+										
50+											50+												50+										
60+											60+												60+										

Position	Data Group		Byte	Bit	Value		Extended Diagnostic Data Interpretation Using GSD	
	Binary	Decimal			Item	Description		
1	Channel Related Data	00	0	1	5	Module Identifier	Reporting identifier(module) number	
2			1	0				
3			2	1				
4			3	0				
5			4	0				
6			5	0				
7			6	0	2	Header Identifier	This is module realted diagnosis header	
8			7	1				
9	Channel Related Data	01	0	0	6	Reporting Channel number	Reporting channel number is 6	
10			1	1				

10) Module detachment diagnostic message

Error information of module operates as Pnet standard id diagnosis message. Now, ID diagnosis data field consists of 3 byte. First byte means it is ID diagnosis field. Second and third bytes mean the slot number of module where diagnosis occurs. Configuration of 3 byte is as follows.

0100 0011

Second byte: means from 0th slot to 7th slot

Third byte: means from 8th slot to 12th slot

(1) PSRA supports both channel and ID diagnostic message. We assume that module detachment occurs at 11th and 12th slot and channel disconnection occurs at CH8 of 6th slot analog module.

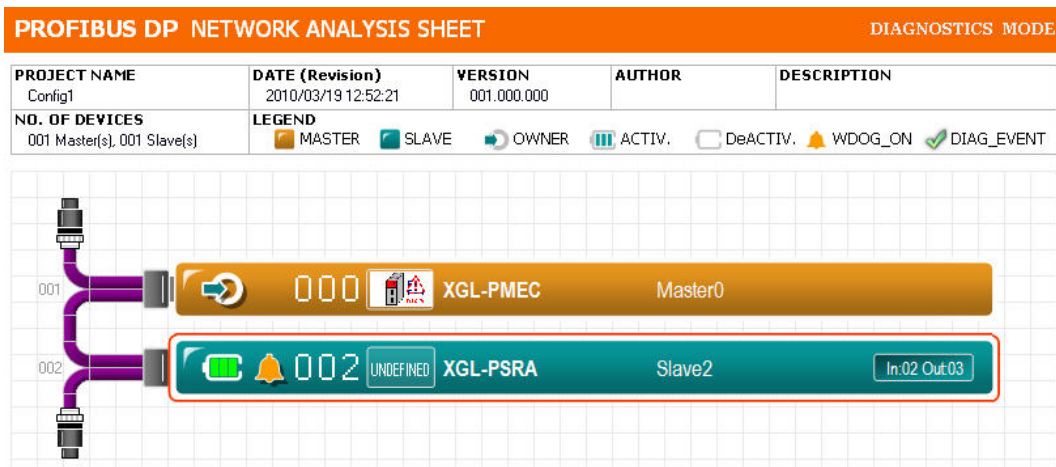

In normal data communication status, no message appears as figure above. If situation described above occurs, diagnostic message is displayed as follows. In case of module detachment, you should reset PSRA to return to data communication status. If you detach module by using module change switch, it is not considered as diagnostic message.



Chapter 8 Trouble Shooting

Extended Diagnostic Information

Device Related Data (Hex)										Module Related Data (Hex)										Channel Related Data (Hex)												
Byte	0	1	2	3	4	5	6	7	8	9	Byte	0	1	2	3	4	5	6	7	8	9	Byte	0	1	2	3	4	5	6	7	8	9
00+											00+	43	02	0C								00+	86	48	B0							
10+											10+											10+										
20+											20+											20+										
30+											30+											30+										
40+											40+											40+										
50+											50+											50+										
60+											60+											60+										

Position	Data Group		Value				Extended Diagnostic Data Interpretation Using GSD	
	Byte	Bit	Binary	Decimal	Item	Description		
1	Module Related Data	00	0	1	3	Block Length	Module related diagnosis block length including header i...	
2			1	1				
3			2	0				
4			3	0				
5			4	0				
6			5	0				
7			6	1				1
8			7	0				
9	Module Related Data	01	0	0	0	(Undefined)	-	
10			1	1	1	Identifier Byte 09	Identifier Byte 09 (Module10) has Diagnosis data	

If we analyze the data in module diagnostic data area in accordance with Pnet standard, it is as follows. Specific message is displayed under that.

Extended Diagnostic Information

Device Related Data (Hex)										Module Related Data (Hex)										Channel Related Data (Hex)												
Byte	0	1	2	3	4	5	6	7	8	9	Byte	0	1	2	3	4	5	6	7	8	9	Byte	0	1	2	3	4	5	6	7	8	9
00+											00+	43	02	0C								00+	86	48	B0							
10+											10+											10+										
20+											20+											20+										
30+											30+											30+										
40+											40+											40+										
50+											50+											50+										
60+											60+											60+										

Position	Data Group		Value				Extended Diagnostic Data Interpretation Using GSD	
	Byte	Bit	Binary	Decimal	Item	Description		
9	Module Related Data	01	0	0	0	(Undefined)	Module has been detached at 2 nd slot.	
10			1	1	1	Identifier Byte 09		
11			2	0	0	(Undefined)		
12			3	0	0	(Undefined)		
13			4	0	0	(Undefined)		
14			5	0	0	(Undefined)		
15			6	0	0	(Undefined)		
16			7	0	0	(Undefined)		
17	Module Related Data	02	0	0	0	(Undefined)	-	
18			1	0	0	(Undefined)	-	

Extended Diagnostic Information

Device Related Data (Hex)										Module Related Data (Hex)										Channel Related Data (Hex)												
Byte	0	1	2	3	4	5	6	7	8	9	Byte	0	1	2	3	4	5	6	7	8	9	Byte	0	1	2	3	4	5	6	7	8	9
00+											00+	43	02	0C								00+	86	48	B0							
10+											10+											10+										
20+											20+											20+										
30+											30+											30+										
40+											40+											40+										
50+											50+											50+										
60+											60+											60+										

Position	Data Group		Bit	Value		Extended Diagnostic Data Interpretation Using GSD	
	Byte	Bit		Binary	Decimal	Item	Description
17	Module Related Data	02	0	0	0	(Undefined)	-
18			1	0	0	(Undefined)	-
19			2	1	1	Module has been detached at 11, 12 th slot.	
20			3	1	1		
21			4	0	0		(Undefined)
22			5	0	0	(Undefined)	-
23			6	0	0	(Undefined)	-
24	7	0	0	(Undefined)	-		
25	Channel Related Data	00	0	0	6	Module Identifier	Reporting identifier(module) number
26			1	1			

The above figure means 2, 11, 12th slot module is detached.

8.2.9 Trouble Shooting Questionnaire

If the trouble occurs when using Pnet remote I/O module, fill in the following questionnaire and contact to the customer center by phone or by fax.

- In case of error related to special and communication module, use the questionnaire added to the user's manual of the corresponding product

1. User contact point :
TEL.)
FAX)
2. Model : ()
3. Applied machine details
– Network status : – OS version (), – Serial no. of product ()
– GMWIN version no. used in program compile :()
4. brief description of control object machine and system :
5. Network model using :
6. ERR LED 'OFF' of network unit? Yes(), No()
7. Error message content by GMWIN :
8. Action trial status for the error code. :
9. Trouble shooting method for other error action :
10. Error features
 - Repeat() : periodical(), specific sequence level related() environment related()
 - Intermittent() : error interval :
11. Detail description for the error phenomena :
12. Configuration diagram of applied system :

Warranty

1. Warranty Period

The product you purchased will be guaranteed for 18 months from the date of manufacturing.

2. Scope of Warranty

Any trouble or defect occurring for the above-mentioned period will be partially replaced or repaired. However, please note the following cases will be excluded from the scope of warranty.

- (1) Any trouble attributable to unreasonable condition, environment or handling otherwise specified in the manual,
- (2) Any trouble attributable to others' products,
- (3) If the product is modified or repaired in any other place not designated by the company,
- (4) Due to unintended purposes
- (5) Owing to the reasons unexpected at the level of the contemporary science and technology when delivered.
- (6) Not attributable to the company; for instance, natural disasters or fire

3. Since the above warranty is limited to PLC unit only, make sure to use the product considering the safety for system configuration or applications.

Environmental Policy

LS Industrial Systems Co., Ltd supports and observes the environmental policy as below.

Environmental Management

LS Industrial Systems considers the environmental preservation as the preferential management subject and every staff of LS Industrial Systems use the reasonable endeavors for the pleasurable environmental preservation of the earth.

About Disposal

LS Industrial Systems' PLC unit is designed to protect the environment. For the disposal, separate aluminum, iron and synthetic resin (cover) from the product as they are reusable.



LS values every single customers.
Quality and service come first at LSIS.
Always at your service, standing for our customers.

<http://eng.lsis.biz>

LS Industrial Systems

10310001027

■ **HEAD OFFICE**

LS tower, Hogye-dong, Dongan-gu, Anyang-si, Gyeonggi-do 1026-6,
 Korea <http://eng.lsis.biz>
 Tel : (82-2)2034-4870/Fax : 82-2-2034-4648 e-mail : cshwang@lsis.biz

■ **LS Industrial Systems Tokyo Office _ Tokyo, Japan**

Address: 16FL. Higashi-Kan. Akasaka Twin Tower 17-22,
 Akasaka.Monato-ku Tokyo 107-8470. Japan
 Tel : 81-3-3582-9128/Fax : 81-3-3582-2667 e-mail : jschuna@lsis.biz

■ **LS Industrial Systems(ME) FZE _ Dubai, U.A.E.**

Address : Jafza View Tower Lob 19, Room 205 Along Sheikh Zayed
 Road Jebel Aali Free Zone Dubai, United Arab Emirates
 Tel : 971-4-886-5360/Fax : 971-4-886-5361 e-mail : jungyongl@lsis.biz

■ **LS Industrial Systems Shanghai Office _ Shanghai, China**

Address : Room E-G. 12FL Hiamin Empire Plaza. No.726. West.
 Yan'an Road Shanghai 200050. P.R. China e-mail : liyong@lsis.com.cn
 Tel : 86-21-5237-9977(609)/Fax : 89-21-5237-7189

■ **LS Industrial Systems Beijing Office _ Beijing, China**

Address : B-Tower 17FL. Beijing Global Trade Center B/D. No. 36.
 East BeisanHuan-Road. DongCheng-District. Beijing 100013. P.R. China
 Tel : 86-10-5825-6027(666)/Fax : 86-10-5825-6028 e-mail : xunmj@lsis.com.cn

■ **LS Industrial Systems Guangzhou Office _ Guangzhou, China**

Address : Room 1403.14FL. New Poly Tower.
 2 Zhongshan Liu Road.Guangzhou.P.R China
 Tel : 86-20-8328-6754/Fax : 86-20-8326-6287 e-mail : chenxs@lsis.com.cn

■ **LS Industrial Systems Chengdu Office _ Chengdu, China**

Address : 12FL. Guodong Buiding. No.52 Jindun
 Road Chengdu.610041. P.R. China
 Tel : 86-28-8612-9151(9226)/Fax : 86-28-8612-9236 e-mail : comysb@lsis.biz

■ **LS Industrial Systems Qingdao Office _ Qingdao, China**

Address : YinHe Bldg. 402 Room No. 2P Shandong Road,
 Qingdao-City,Shandong-province 266071, P.R. China
 Tel : 86-532-8501-6068/Fax : 86-532-8501-6057 e-mail : wangzy@lsis.com.cn

■ **LS Industrial Systems Europe B.V. , Netherlands**

Address : 1st. Floor, Tupolevlaan 48, 1119NZ, Schiphol-Rijk, The Netherlands
 Tel : +31 (0)20 654 1420/Fax : +31 (0)20 654 1429 e-mail : junshickp@lsis.biz

■ **Wuxi LS Industrial Systems Co., Ltd _ Wuxi, China**

Address : 102-A. National High & New Tech Industrial Development Area.
 Wuxi. Jiangsu. 214028. P.R. China
 Tel : 86-510-8534-6666/Fax : 86-510-8534-4078 e-mail : caidx@lsis.com.cn

■ **Dalian LS Industrial Systems Co., Ltd. _ Dalian, China**

Address : No. 15. Liaohexi 3-Road. Economic and Technical Development zone.
 Dalian 116600. China
 Tel : 86-411-273-7777/Fax : 86-411-8730-7560 e-mail : cuibx@lsis.com.cn

※ LS Industrial Systems constantly endeavors to improve its product so that information in this manual is subject to change without notice.

© LS Industrial Systems Co., Ltd 2010 All Rights Reserved.

2010. 5