

Modicon TM5

Analog I/O Modules

Hardware Guide

04/2012



The information provided in this documentation contains general descriptions and/or technical characteristics of the performance of the products contained herein. This documentation is not intended as a substitute for and is not to be used for determining suitability or reliability of these products for specific user applications. It is the duty of any such user or integrator to perform the appropriate and complete risk analysis, evaluation and testing of the products with respect to the relevant specific application or use thereof. Neither Schneider Electric nor any of its affiliates or subsidiaries shall be responsible or liable for misuse of the information contained herein. If you have any suggestions for improvements or amendments or have found errors in this publication, please notify us.

No part of this document may be reproduced in any form or by any means, electronic or mechanical, including photocopying, without express written permission of Schneider Electric.

All pertinent state, regional, and local safety regulations must be observed when installing and using this product. For reasons of safety and to help ensure compliance with documented system data, only the manufacturer should perform repairs to components.

When devices are used for applications with technical safety requirements, the relevant instructions must be followed.

Failure to use Schneider Electric software or approved software with our hardware products may result in injury, harm, or improper operating results.

Failure to observe this information can result in injury or equipment damage.

© 2012 Schneider Electric. All rights reserved.

Table of Contents

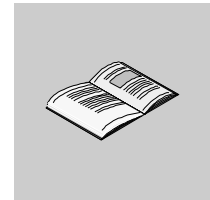

	Safety Information	7
	About the Book	9
Part I	TM5 Analog I/O General Overview	13
Chapter 1	TM5 System General Rules for Implementing	15
	Installation Requirements	16
	Wiring Rules and Recommendations	19
	Environmental Characteristics	23
	Installation Guidelines	26
	Hot Swapping Electronic Modules	27
Chapter 2	TM5 Analog I/O General Overview	31
	General Description	32
	Physical Description	35
Part II	TM5 System Analog Input Electronic Modules ...	39
Chapter 3	TM5SAI•L Analog 12 Bits Input Electronic Module . . .	41
3.1	TM5SAI2L Electronic Module 2AI $\pm 10V/0-20mA/4-20mA$ 12 Bits	42
	TM5SAI2L Presentation	43
	TM5SAI2L Characteristics	45
	TM5SAI2L Wiring Diagram	47
3.2	TM5SAI4L Electronic Module 4AI $\pm 10V/0-20mA/4-20mA$ 12 Bits	49
	TM5SAI4L Presentation	50
	TM5SAI4L Characteristics	52
	TM5SAI4L Wiring Diagram	54
Chapter 4	TM5SAI•H Analog 16 Bits Input Electronic Module . . .	57
4.1	TM5SAI2H Electronic Module 2AI $\pm 10V/0-20mA$ 16 Bits	58
	TM5SAI2H Presentation	59
	TM5SAI2H Characteristics	61
	TM5SAI2H Wiring Diagram	63
4.2	TM5SAI4H Electronic Module 4AI $\pm 10V/0-20mA$ 16 Bits	66
	TM5SAI4H Presentation	67
	TM5SAI4H Characteristics	69
	TM5SAI4H Wiring Diagram	72

Chapter 5	TM5SAI•PH Analog 16 Bits Temperature Input Electronic Module PT100/PT1000	75
5.1	TM5SAI2PH Electronic Module 2AI PT100/PT1000 16 Bits	76
	TM5SAI2PH Presentation	77
	TM5SAI2PH Characteristics	79
	TM5SAI2PH Wiring Diagram	81
5.2	TM5SAI4PH Electronic Module 4AI PT100/PT1000 16 Bits	84
	TM5SAI4PH Presentation	85
	TM5SAI4PH Characteristics	87
	TM5SAI4PH Wiring Diagram	89
Chapter 6	TM5SAI•TH Analog 16 Bits Temperature Input Electronic Module Thermocouple J/K/N/S	93
6.1	TM5SAI2TH Electronic Module 2AI Thermocouple J/K/N/S 16 Bits	94
	TM5SAI2TH Presentation	95
	TM5SAI2TH Characteristics	98
	TM5SAI2TH Wiring Diagram	100
6.2	TM5SAI6TH Electronic Module 6AI Thermocouple J/K/N/S 16 Bits	103
	TM5SAI6TH Presentation	104
	TM5SAI6TH Characteristics	107
	TM5SAI6TH Wiring Diagram	109
Chapter 7	TM5SEAISG Analog Strain Gauge Input Electronic Module	113
	TM5SEAISG Presentation	114
	TM5SEAISG Characteristics	116
	TM5SEAISG Wiring Diagram	119
Part III	TM5 System Analog Output Electronic Modules	123
Chapter 8	TM5SAO•• Analog Output Electronic Module	125
8.1	TM5SAO2L Electronic Module 2AO $\pm 10V/0-20mA$ 12 Bits	126
	TM5SAO2L Presentation	127
	TM5SAO2L Characteristics	129
	TM5SAO2L Wiring Diagram	131
8.2	TM5SAO4L Electronic Module 4AO $\pm 10V/0-20mA$ 12 Bits	133
	TM5SAO4L Presentation	134
	TM5SAO4L Characteristics	136
	TM5SAO4L Wiring Diagram	140
8.3	TM5SAO2H Electronic Module 2AO $\pm 10V/0-20mA$ 16 Bits	142
	TM5SAO2H Presentation	143
	TM5SAO2H Characteristics	145
	TM5SAO2H Wiring Diagram	147

8.4	TM5SAO4H Electronic Module 4AO $\pm 10V/0-20mA$ 16 Bits	149
	TM5SAO4H Presentation	150
	TM5SAO4H Characteristics	152
	TM5SAO4H Wiring Diagram	156
Glossary	159
Index	167

Safety Information

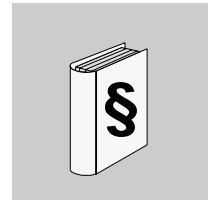

Important Information

NOTICE

Read these instructions carefully, and look at the equipment to become familiar with the device before trying to install, operate, or maintain it. The following special messages may appear throughout this documentation or on the equipment to warn of potential hazards or to call attention to information that clarifies or simplifies a procedure.



The addition of this symbol to a Danger safety label indicates that an electrical hazard exists, which will result in personal injury if the instructions are not followed.



This is the safety alert symbol. It is used to alert you to potential personal injury hazards. Obey all safety messages that follow this symbol to avoid possible injury or death.

DANGER

DANGER indicates an imminently hazardous situation which, if not avoided, **will result in** death or serious injury.

WARNING

WARNING indicates a potentially hazardous situation which, if not avoided, **can result in** death or serious injury.

 **CAUTION**

CAUTION indicates a potentially hazardous situation which, if not avoided, **can result in** minor or moderate injury.

NOTICE

NOTICE is used to address practices not related to physical injury.

PLEASE NOTE

Electrical equipment should be installed, operated, serviced, and maintained only by qualified personnel. No responsibility is assumed by Schneider Electric for any consequences arising out of the use of this material.

A qualified person is one who has skills and knowledge related to the construction and operation of electrical equipment and its installation, and has received safety training to recognize and avoid the hazards involved.

About the Book

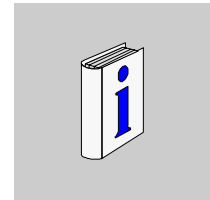

At a Glance

Document Scope

This manual describes the hardware implementation of the ModiconTM5 Analog I/O modules. It provides parts descriptions, specifications, wiring diagrams, installation and setup for Modicon TM5 Analog I/O modules.

Validity Note

This document has been updated with the release of SoMachine V3.1.

The technical characteristics of the device(s) described in this manual also appear online. To access this information online:

Step	Action
1	Go to the Schneider Electric home page www.schneider-electric.com .
2	In the Search box type the model number of a product or the name of a product range. <ul style="list-style-type: none">• Do not include blank spaces in the model number/product range.• To get information on a grouping similar modules, use asterisks (*).
3	If you entered a model number, go to the Product datasheets search results and click on the model number that interests you. If you entered the name of a product range, go to the Product Ranges search results and click on the product range that interests you.
4	If more than one model number appears in the Products search results, click on the model number that interests you.
5	Depending on the size of your screen, you may need to scroll down to see the data sheet.
6	To save or print a data sheet as a .pdf file, click Download XXX product datasheet .

The characteristics presented in this manual should be the same as those that appear online. In line with our policy of constant improvement we may revise content over time to improve clarity and accuracy. In the event that you see a difference between the manual and online information, use the online information as your reference.

Related Documents

Title of Documentation	Reference Number
Modicon TM5 Expansion Modules Configuration Programming Guide	EIO0000000420 (Eng), EIO0000000421 (Fre), EIO0000000422 (Ger), EIO0000000423 (Spa), EIO0000000424 (Ita), EIO0000000425 (Chs)
Modicon TM5 IoDrvTM5SEAIISG Strain Gauge Library Guide	EIO0000001185 (Eng), EIO0000001186 (Fre), EIO0000001187 (Ger), EIO0000001188 (Spa), EIO0000001189 (Ita), EIO0000001190 (Chs)
Modicon Flexible TM5 / TM7 System - System Planning and Installation Guide	EIO0000000426 (Eng), EIO0000000427 (Fre), EIO0000000428 (Ger), EIO0000000429 (Spa), EIO0000000430 (Ita), EIO0000000431 (Chs)
TM5 AIO Modules Instruction Sheet	BBV56047

You can download these technical publications and other technical information from our website at www.schneider-electric.com.

Product Related Information

DANGER

HAZARD OF ELECTRIC SHOCK, EXPLOSION OR ARC FLASH

- Disconnect all power from all equipment including connected devices prior to removing any covers or doors, or installing or removing any accessories, hardware, cables, or wires except under the specific conditions specified in the appropriate hardware guide for this equipment.
- Always use a properly rated voltage sensing device to confirm the power is off where and when indicated.
- Replace and secure all covers, accessories, hardware, cables, and wires and confirm that a proper ground connection exists before applying power to the unit.
- Use only the specified voltage when operating this equipment and any associated products.

Failure to follow these instructions will result in death or serious injury.

DANGER

EXPLOSIVE POTENTIAL

- Only use this equipment in non-hazardous locations, or in locations that comply with Class I, Division 2, Groups A, B, C and D.
- Do not substitute components which would impair compliance to Class I Division 2.
- Do not connect or disconnect equipment unless power has been removed or the location is known to be non-hazardous.

Failure to follow these instructions will result in death or serious injury.

WARNING

LOSS OF CONTROL

- The designer of any control scheme must consider the potential failure modes of control paths and, for certain critical control functions, provide a means to achieve a safe state during and after a path failure. Examples of critical control functions are emergency stop and overtravel stop, power outage and restart.
- Separate or redundant control paths must be provided for critical control functions.
- System control paths may include communication links. Consideration must be given to the implications of unanticipated transmission delays or failures of the link.
- Observe all accident prevention regulations and local safety guidelines.¹
- Each implementation of this equipment must be individually and thoroughly tested for proper operation before being placed into service.

Failure to follow these instructions can result in death, serious injury, or equipment damage.

¹ For additional information, refer to NEMA ICS 1.1 (latest edition), "Safety Guidelines for the Application, Installation, and Maintenance of Solid State Control" and to NEMA ICS 7.1 (latest edition), "Safety Standards for Construction and Guide for Selection, Installation and Operation of Adjustable-Speed Drive Systems" or their equivalent governing your particular location.

WARNING

UNINTENDED EQUIPMENT OPERATION

- Only use software approved by Schneider Electric for use with this equipment.
- Update your application program every time you change the physical hardware configuration.

Failure to follow these instructions can result in death, serious injury, or equipment damage.

User Comments

We welcome your comments about this document. You can reach us by e-mail at techcomm@schneider-electric.com.

TM5 Analog I/O General Overview

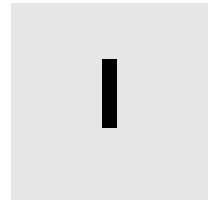

What's in this Part?

This part contains the following chapters:

Chapter	Chapter Name	Page
1	TM5 System General Rules for Implementing	15
2	TM5 Analog I/O General Overview	31

TM5 System General Rules for Implementing

1

What's in this Chapter?

This chapter contains the following topics:

Topic	Page
Installation Requirements	16
Wiring Rules and Recommendations	19
Environmental Characteristics	23
Installation Guidelines	26
Hot Swapping Electronic Modules	27

Installation Requirements

Before Starting

Read and understand this chapter before beginning the installation of your TM5 System.

DANGER

HAZARD OF ELECTRIC SHOCK, EXPLOSION OR ARC FLASH

- Disconnect all power from all equipment including connected devices prior to removing any covers or doors, or installing or removing any accessories, hardware, cables, or wires except under the specific conditions specified in the appropriate hardware guide for this equipment.
- Always use a properly rated voltage sensing device to confirm the power is off where and when indicated.
- Replace and secure all covers, accessories, hardware, cables, and wires and confirm that a proper ground connection exists before applying power to the unit.
- Use only the specified voltage when operating this equipment and any associated products.

Failure to follow these instructions will result in death or serious injury.

NOTICE

ELECTROSTATIC DISCHARGE

- Store all components in their protective packaging until immediately before assembly.
- Never touch exposed conductive parts such as contacts or terminals.

Failure to follow these instructions can result in equipment damage.

Programming Considerations

WARNING

UNINTENDED EQUIPMENT OPERATION

- Only use software approved by Schneider Electric for use with this equipment.
- Update your application program every time you change the physical hardware configuration.

Failure to follow these instructions can result in death, serious injury, or equipment damage.

Operating Environment

DANGER

EXPLOSIVE POTENTIAL

- Only use this equipment in non-hazardous locations, or in locations that comply with Class I, Division 2, Groups A, B, C and D.
- Do not substitute components which would impair compliance to Class I Division 2.
- Do not connect or disconnect equipment unless power has been removed or the location is known to be non-hazardous.

Failure to follow these instructions will result in death or serious injury.

WARNING

UNINTENDED EQUIPMENT OPERATION

Install and operate this equipment according to the environmental conditions described in the operating limits.

Failure to follow these instructions can result in death, serious injury, or equipment damage.

Installation Considerations

WARNING

UNINTENDED EQUIPMENT OPERATION

- Use appropriate safety interlocks where personnel and/or equipment hazards exist.
- Install and operate this equipment in an enclosure appropriately rated for its intended environment.
- Use the sensor and actuator power supplies only for supplying power to the sensors or actuators connected to the module.
- Power line and output circuits must be wired and fused in compliance with local and national regulatory requirements for the rated current and voltage of the particular equipment.
- Do not use this equipment in safety-critical machine functions.
- Do not disassemble, repair, or modify this equipment.
- Do not connect any wiring to reserved, unused connections, or to connections designated as Not Connected (N.C.).

Failure to follow these instructions can result in death, serious injury, or equipment damage.

NOTE: Schneider Electric recommends the use of UL-recognized and CSA approved JDYX2 or JDYX8 fuse types.

Wiring Rules and Recommendations

Introduction

There are several rules that must be followed when wiring the TM5 System.

Wiring Rules



HAZARD OF ELECTRIC SHOCK, EXPLOSION OR ARC FLASH

- Disconnect all power from all equipment including connected devices prior to removing any covers or doors, or installing or removing any accessories, hardware, cables, or wires except under the specific conditions specified in the appropriate hardware guide for this equipment.
- Always use a properly rated voltage sensing device to confirm the power is off where and when indicated.
- Replace and secure all covers, accessories, hardware, cables, and wires and confirm that a proper ground connection exists before applying power to the unit.
- Use only the specified voltage when operating this equipment and any associated products.

Failure to follow these instructions will result in death or serious injury.

The following rules must be applied when wiring the TM5 System:

- I/O and communication wiring must be kept separate from the power wiring. Route these 2 types of wiring in separate cable ducting.
- Verify that the operating conditions and environment are within the specification values.
- Use proper wire sizes to meet voltage and current requirements.
- Use copper conductors only.
- Use twisted-pair, shielded cables for analog, expert or fast I/O and TM5 bus signals.
- Use twisted-pair, shielded cables for encoder, networks and field bus (CAN, serial, Ethernet).

⚠ WARNING

IMPROPER GROUNDING CAN CAUSE UNINTENDED EQUIPMENT OPERATION





- Use cables with insulated shielded jackets for analog I/O, fast I/O and communication signals.
- Ground shielded cables for analog I/O, fast I/O and communication signals at a single point ¹
- Always comply with local wiring requirements regarding grounding of cable shields.

Failure to follow these instructions can result in death, serious injury, or equipment damage.

NOTE: ¹Multipoint grounding is permissible if connections are made to an equipotential ground plane dimensioned to help avoid cable shield damage in the event of power system short circuit currents.

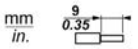
Refer to the section Grounding the TM5 System (see *Modicon TM5 / TM7 Flexible System, System Planning and Installation Guide*) to ground the shielded cables.

The table below provides the wire sizes to use with the removable spring terminal blocks:

 mm in.				
mm ²	0,08...2,5	0,25...2,5	0,25...1,5	2 x 0,25...2 x 0,75
AWG	28...14	24...14	24...16	2 x 24...2 x 18

⚠ DANGER

FIRE HAZARD

Use only the recommended wire sizes for I/O channels and power supplies.

Failure to follow these instructions will result in death or serious injury.

The spring clamp connectors of the terminal block are designed for only one wire or one cable end. Two wires to the same connector must be installed with a double wire cable end to help prevent loosening.

⚠ DANGER**LOOSE WIRING CAUSES ELECTRIC SHOCK**

Do not insert more than one wire per connector of the terminal block without a double wire cable end.

Failure to follow these instructions will result in death or serious injury.

Terminal Block

Plugging a terminal block into the incorrect electronic module can cause an electric shock or unintended operation of the application and/or damage the electronic module.

⚠ DANGER**UNINTENDED EQUIPMENT OPERATION OR ELECTRIC SHOCK**

Be sure to connect the terminal blocks to their designated location.

Failure to follow these instructions will result in death or serious injury.

NOTE: To help prevent a terminal block from being inserted incorrectly, clearly and uniquely code and label each terminal block and electronic module according to the instructions in *Coding the TM5 System (see Modicon TM5 / TM7 Flexible System, System Planning and Installation Guide)*.

Stress Relief Using Cable Tie

There are two methods to reduce the stress on cables:

- The terminal blocks (*see Modicon TM5 / TM7 Flexible System, System Planning and Installation Guide*) have slots to attach cable ties. A cable tie can be fed through this slot to secure cables and wires to reduce stress between them and the terminal block connections.
- After grounding the TM5 System via the TM2XMTGB grounding plate (*see Modicon TM5 / TM7 Flexible System, System Planning and Installation Guide*), wires can be bundled and fixed to the grounding plate tabs using wire ties to reduce stress on the cables.

The table below provides the size of the cable tie and shows the two methods to reduce the stress on the cables:

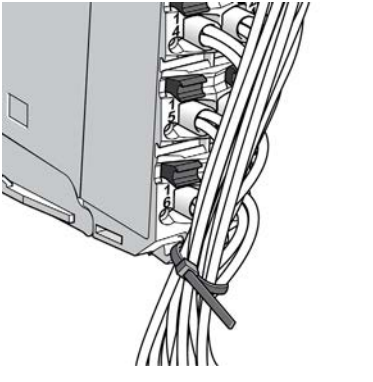
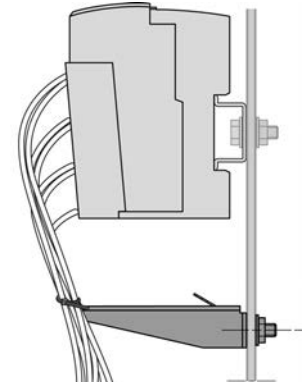
Cable Tie Size	Terminal block	TM2XMTGB Grounding plate
Thickness	1.2 mm (0.05 in.) maximum	1.2 mm (0.05 in.)
Width	4 mm (0.16 in.) maximum	2.5...3 mm (0.1...0.12 in.)
Mounting figure		

Environmental Characteristics

Introduction

The following information describes the system-wide environmental requirements and characteristics for the TM5 System.

The general environmental characteristics are common to all components of the TM5 System.

Enclosure Requirements

TM5 components are designed as Zone B, Class A industrial equipment according to IEC/CISPR Publication 11. If they are used in environments other than those described in the standard, or in environments that do not meet the specifications in this manual, your ability to meet electromagnetic compatibility requirements in the presence of conducted and/or radiated interference may be reduced.

All TM5 components meet European Community (CE) requirements for open equipment as defined by EN61131-2. You must install them in an enclosure designed for the specific environmental conditions and to minimize the possibility of unintended contact with hazardous voltages. Your enclosure should be constructed of metal to improve the electromagnetic immunity of your TM5 System. Your enclosure should have a keyed locking mechanism to minimize unauthorized access.

Environmental Characteristics

This equipment meets UL, CSA, GOST-R and c-Tick certifications and CE requirements as indicated in the table below. This equipment is intended for use in a Pollution Degree 2 industrial environment.

The table below provides the general environmental characteristics:

Characteristic	Specification	
This product is compliant with Europe RoHS recommendations and China RoHS regulations. 		
Standard	IEC61131-2 ed. 3 2007	
Agencies	UL 508 CSA 22.2 No. 142-M1987 CSA 22.2 No. 213-M1987	
Ambient operating temperature	Horizontal installation	-10...60 °C (14...140 °F) ^{1, 2}
	Vertical installation	-10...50 °C (14...122 °F) ²
Storage temperature	-40...70 °C (-40...158 °F)	
Relative humidity	5...95% (non-condensing)	

Characteristic	Specification	
Degree of pollution	IEC60664	2
Degree of protection	IEC61131-2	IP20
Corrosion immunity	No	
Operating altitude	0...2000 m (0...6.560 ft.)	
Storage altitude	0...3000 m (0...9.842 ft.)	
Vibration resistance	Mounted on a DIN rail	3.5 mm (0.138 in.) fixed amplitude from 5...8.4 Hz 9.8 m/s ² (1 g _n) fixed acceleration from 8.4...150 Hz
Mechanical shock resistance	147 m/s ² (15 g _n) for a duration of 11 ms	
Connection type	Removable spring terminal block	
Connector insertion/removal cycles	50	
<p>Note:</p> <p>1 Some devices have temperature operating restrictions that require de-rating between 55 °C and 60 °C (131 °F and 140 °F), and may be subject to other possible restrictions. See the specific characteristics for your electronic module.</p> <p>2 For compliance to Class I, Div 2 environment ratings, do not operate this device in locations with ambient temperatures less than 0 °C (32° F).</p>		

Electromagnetic Susceptibility

The table below provides the TM5 System electromagnetic susceptibility specifications:

Characteristic	Specification	Range
Electrostatic discharge	IEC/EN 61000-4-2	8 kV (air discharge) 4 kV (contact discharge)
Electromagnetic fields	IEC/EN 61000-4-3	10 V/m (80 MHz...2 GHz) 1 V/m (2...2.7 GHz)
Fast transients burst	IEC/EN 61000-4-4	Power lines: 2 kV I/O: 1 kV Shielded cable: 1 kV Repetition rate: 5 and 100 KHz
Surge immunity 24 Vdc circuit	IEC/EN 61000-4-5	1 kV in common mode 0.5 kV in differential mode
Surge immunity 230 Vac circuit		2 kV in common mode 1 kV in differential mode
Induced electromagnetic field	IEC/EN 61000-4-6	10 V _{eff} (0.15...80 MHz)

Characteristic	Specification	Range
Conducted emission	EN 55011 (IEC/CISPR11)	150...500 kHz, quasi peak 79 dB μ V
		500 kHz...30 MHz, quasi peak 73 dB μ V
Radiated emission	EN 55011 (IEC/CISPR11)	30...230 MHz, 10 m@40 dB μ V/m
		230 MHz...1 GHz, 10 m@47 dB μ V/m

Installation Guidelines

Installation

The following table provides documentation references for spacing requirements and installation of electronic modules and accessories:

Spacing requirement	For mounting positions and minimum clearances, the electronic modules are mounted according to the rules defined for the controllers. Refer to the <i>Enclosing the TM5 System (see Modicon TM5 / TM7 Flexible System, System Planning and Installation Guide)</i> . NOTE: The TM5 System is designed to operate between - 10°C (14°F) and 55°C (131°F) without derating and up to 60°C (140°F) with some special rules and some derating on some products.
Electronic modules installation	Refer to: <ul style="list-style-type: none"> ● <i>TM5 Association Table (see Modicon TM5 / TM7 Flexible System, System Planning and Installation Guide)</i>. ● <i>Expanding the TM5 System (see Modicon TM5 / TM7 Flexible System, System Planning and Installation Guide)</i>.
Accessories installation	Refer to the <i>Installation of Accessories (see Modicon TM5 / TM7 Flexible System, System Planning and Installation Guide)</i> .

Hot Swapping Electronic Modules

Definition

Hot swapping is the ability to remove an I/O electronic module from its bus base and then replace it with an identical electronic module while the TM5 System is under power without disrupting the normal operations of the controller. When the electronic module is returned to its bus base or replaced with another electronic module with the same reference, it starts to operate again.

Hot Swapping Considerations

Before initiating a hot swap operation, confirm that the electronic module type is approved for hot swapping (*see page 29*).

When removing or inserting an I/O module while power is applied, remove and insert the electronic module by hand. Do not use tools to hot swap modules because they may come into contact with hazardous voltages. Also, remove any locking clips and the terminal block before removing the electronic module from its bus base. Hot swapping is only allowed when replacing identical electronic modules.

DANGER

EXPLOSION OR ELECTRIC SHOCK

- Only perform a hot swap operation in locations known to be non-hazardous.
- Use only your hands.
- Do not use any metal tools.
- Do not disconnect any wires from the terminal block.
- Only replace an electronic module with an identical reference.

Failure to follow these instructions will result in death or serious injury.

NOTE: Only the electronic module is hot swap-able. Do not attempt a hot swap operation on the bus base, or on electronic modules that are integrated with their bus bases such as the compact I/O.

You need to understand and plan for the consequences of hot-swapping certain modules. Hot-swapping modules that control power distribution to other modules, for example, can impact your machine or process. Power Distribution modules, Interface Power Distribution Modules, Common Distribution modules, Field Bus Interface Modules, and Transmitter and Receiver modules all either distribute power or communications to other electronic modules. Disconnecting the connector to these modules will interrupt power or communications to the modules they service.

For example, some Power Distribution Modules (PDMs) provide power to both the TM5 power bus and 24 Vdc I/O power segment. It is possible that you may need to replace the PDM because one service is inoperable, but not both. In this case, hot-swapping the PDM would interrupt the service that is still operating, and would interrupt power to the modules drawing power from that service.

I/O configurations that employ Common Distribution modules require careful consideration when wiring is restricted by short wire lengths. It may be the case that in order to hot-swap an electronic module that has become inoperable, you need to disconnect the connector of the Common module servicing it. Further, that same Common module may be connected to modules or devices other than the module you wish to hot-swap. Disconnecting the Common module in this case would necessarily interrupt the supply to the unaffected modules and/or devices. Be sure that you know what I/O slices or devices are connected to the Common module, and the impact that this disconnection would have on your machine or process before attempting a hot-swap operation.

WARNING

LOSS OF CONTROL

- The designer of any control scheme must consider the potential failure modes of control paths and, for certain critical control functions, provide a means to achieve a safe state during and after a path failure. Examples of critical control functions are emergency stop and overtravel stop, power outage and restart.
- Separate or redundant control paths must be provided for critical control functions.
- System control paths may include communication links. Consideration must be given to the implications of unanticipated transmission delays or failures of the link.
- Observe all accident prevention regulations and local safety guidelines.¹
- Each implementation of this equipment must be individually and thoroughly tested for proper operation before being placed into service.

Failure to follow these instructions can result in death, serious injury, or equipment damage.

¹ For additional information, refer to NEMA ICS 1.1 (latest edition), "Safety Guidelines for the Application, Installation, and Maintenance of Solid State Control" and to NEMA ICS 7.1 (latest edition), "Safety Standards for Construction and Guide for Selection, Installation and Operation of Adjustable-Speed Drive Systems" or their equivalent governing your particular location.

NOTE: Be sure you thoroughly understand the consequences of a hot-swap operation on all modules and connected devices as they relate to your machine or process.

Modules that are not Hot Swap-able

Electronic modules that can not be hot swapped under any circumstances include:

TM5	Electronic Modules Type	Reasons
Controller	PCI communication	The replacement of the PCI communication module requires a power cycle before it will be recognized by the controller.
	Controller Power Distribution Module	These modules are not removable.
	Embedded I/O Modules	
Field bus interface	CANopen interface module	The replacement of the CANopen interface module depends on CANopen master architecture. Refer to the Generic CANopen Implementation Guide and documentations associated to the CANopen master.
Compact I/O	I/O modules	These modules are not removable.

TM5 Analog I/O General Overview

2

What's in this Chapter?

This chapter contains the following topics:

Topic	Page
General Description	32
Physical Description	35

General Description

Introduction

The range of analog electronic modules includes:

- Analog input electronic modules
- Analog temperature input electronic modules
- Analog output electronic modules

The TM5 analog I/O electronic modules need to be associated with a bus base and a terminal block. Every analog electronic module channel has a status LED.

Analog Input Electronic Module Features

Analog input electronic modules convert measured values (voltages, currents) into numeric values, which can be processed by the controller.

Each channel in an electronic module is capable of converting either current or voltage signals. There are different terminal connection points for each type of signal. Since current and voltage require different adjustment values, it is also necessary to configure the desired type of input signal:

- -10...+10 Vdc voltage signal (default).
- 0...20 mA current signal.
- 4...20 mA current signal.

The following table shows the analog input electronic modules features:

Reference	Number of Channels	Digital Converter Resolution	Voltage/Current
TM5SAI2L <i>(see page 43)</i>	2	12 bit + sign 12 bit	-10...+10 Vdc 0...20 mA/4...20 mA
TM5SAI4L <i>(see page 50)</i>	4	12 bit + sign 12 bit	-10...+10 Vdc 0...20 mA/4...20 mA
TM5SAI2H <i>(see page 59)</i>	2	15 bit + sign 15 bit	-10...+10 Vdc 0...20 mA
TM5SAI4H <i>(see page 67)</i>	4	15 bit + sign 15 bit	-10...+10 Vdc 0...20 mA

Analog Temperature Electronic Module Features

Temperature measurement values are converted into numeric values which can be processed by the controller using temperature electronic modules. For temperature measurements, the temperature electronic module returns the measured value in 0.1°C steps.

The step value 0.1°C (0.18°F) is supported as standard by all temperature electronic modules.

The following table shows the analog temperature input electronic modules features:

Reference	Number of Channels	Digital Converter Resolution	Sonde Type
TM5SAI2PH (see page 77)	2	16 bit	PT100/1000
TM5SAI4PH (see page 85)	4	16 bit	PT100/1000
TM5SAI2TH (see page 95)	2	16 bit	Thermocouple J, K, N, S
TM5SAI6TH (see page 104)	6	16 bit	Thermocouple J, K, N, S

Analog Strain Gauge Input Electronic Module Features

The TM5SEAISG is an analog module which allows to convert the output of a 4-wire or 6-wire full-bridge strain gauge to a numeric value.

The following table shows the strain gauge input electronic module features:

Reference	Number of Channels	Digital Converter Resolution	Sensor Type
TM5SEAISG (see page 114)	1	24 bit	Full-bridge strain gauge

Analog Output Electronic Module Features

Analog output electronic modules convert controller internal numeric values into voltages or currents.

The following table shows the analog output electronic modules features:

Reference	Number of Channels	Digital Converter Resolution	Voltage/Current
TM5SAO2L <i>(see page 127)</i>	2	12 bit + sign 12 bit	-10...+10 Vdc 0...20 mA
TM5SAO4L <i>(see page 134)</i>	4	12 bit + sign 12 bit	-10...+10 Vdc 0...20 mA
TM5SAO2H <i>(see page 143)</i>	2	15 bit + sign 15 bit	-10...+10 Vdc 0...20 mA
TM5SAO4H <i>(see page 150)</i>	4	15 bit + sign 15 bit	-10...+10 Vdc 0...20 mA

Physical Description

Introduction

Each slice consists of three elements. These elements are the bus base, the electronic module and the terminal block.

Elements

The following figure shows the elements of a slice.

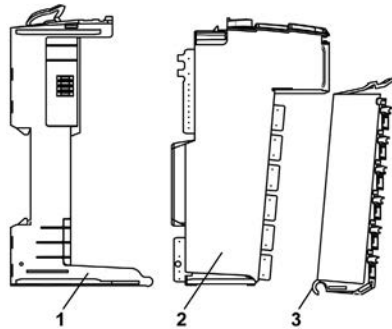

1. Bus base
2. Electronic module
3. Terminal block

When assembled the three components form an integral unit that resists vibration and electrostatic discharge.

NOTICE

ELECTROSTATIC DISCHARGE

- Never touch the contacts of the electronic module.
- Always keep the connector in place during normal operation.

Failure to follow these instructions can result in equipment damage.

Dimensions

The following figure shows the dimensions of a slice:

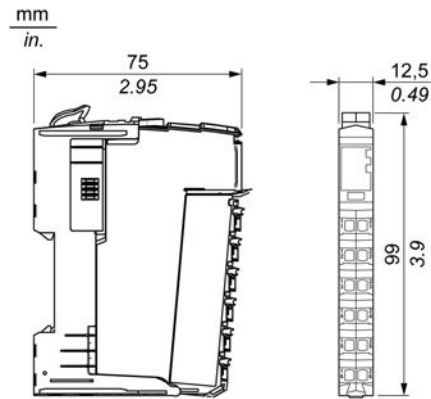

Pin Assignment

The following figure shows the pin assignments respectively for the 6-pin and the 12-pin terminal blocks:

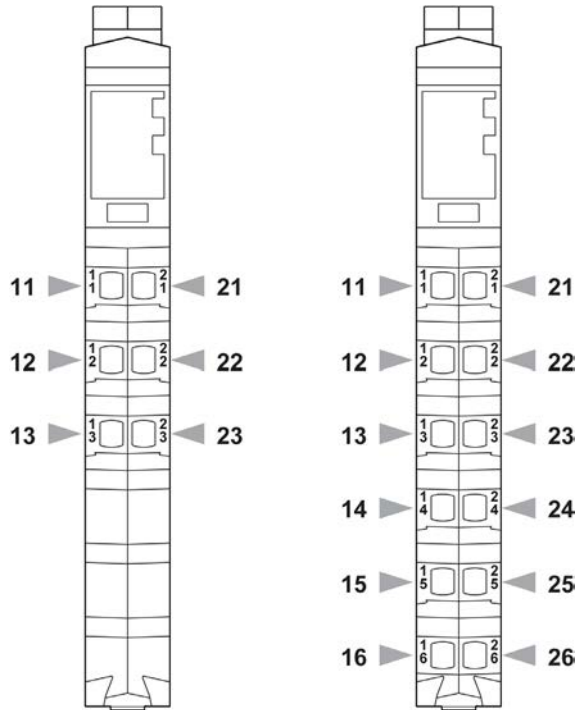

Accessories

Refer to the *Installation of Accessories* (see *Modicon TM5 / TM7 Flexible System, System Planning and Installation Guide*).

Labeling

Refer to the *Labeling the TM5 System* (see *Modicon TM5 / TM7 Flexible System, System Planning and Installation Guide*).

TM5 System Analog Input Electronic Modules

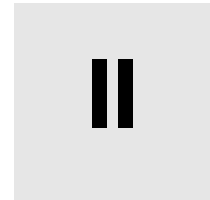

What's in this Part?

This part contains the following chapters:

Chapter	Chapter Name	Page
3	TM5SAI•L Analog 12 Bits Input Electronic Module	41
4	TM5SAI•H Analog 16 Bits Input Electronic Module	57
5	TM5SAI•PH Analog 16 Bits Temperature Input Electronic Module PT100/PT1000	75
6	TM5SAI•TH Analog 16 Bits Temperature Input Electronic Module Thermocouple J/K/N/S	93
7	TM5SEAISG Analog Strain Gauge Input Electronic Module	113

TM5SAI•L Analog 12 Bits Input Electronic Module

3

What's in this Chapter?

This chapter contains the following sections:

Section	Topic	Page
3.1	TM5SAI2L Electronic Module 2AI $\pm 10V/0-20mA/4-20mA$ 12 Bits	42
3.2	TM5SAI4L Electronic Module 4AI $\pm 10V/0-20mA/4-20mA$ 12 Bits	49

3.1 **TM5SAI2L Electronic Module 2AI $\pm 10V/0-20mA/4-20mA$ 12 Bits**

What's in this Section?

This section contains the following topics:

Topic	Page
TM5SAI2L Presentation	43
TM5SAI2L Characteristics	45
TM5SAI2L Wiring Diagram	47

TM5SAI2L Presentation

Main Characteristics

The table below describes the main characteristics of the TM5SAI2L electronic module:

Main Characteristics		
Number of input channels	2	
Signal type	Voltage	Current
Input range	-10...+10 Vdc	0...20 mA / 4...20 mA
Resolution	12 bits + sign	12 bits

Ordering Information

The following figure shows the slice with a TM5SAI2L:

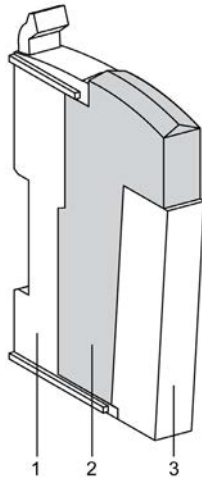

The table below shows the model numbers for the terminal block and bus base associated to TM5SAI2L:

Number	Model Number	Description	Color
1	TM5ACBM11	Bus base	White
	or TM5ACBM15	Bus base with address setting	White
2	TM5ASAI2L	Electronic module	White

Number	Model Number	Description	Color
3	TM5ACTB06	Terminal block, 6 pins	White
	or TM5ACTB12	Terminal block, 12 pins	White

NOTE: For more information, refer to *TM5 bus bases and terminal blocks* (see *Modicon TM5 / TM7 Flexible System, System Planning and Installation Guide*)

Status LEDs

The following figure shows the TM5SAI2L status LEDs:

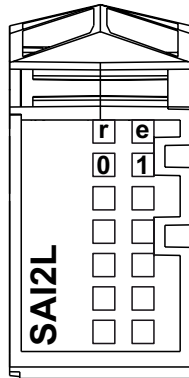

The table below shows the TM5SAI2L status LEDs:

LED	Color	Status	Description
r	Green	Off	No power supply
		Single Flash	Reset state
		Flashing	Preoperational state
		On	Normal operation
e	Red	Off	OK or no power supply
		On	Detected error or reset state
		Double Flash	System detected error: <ul style="list-style-type: none"> ● Scan time overrun ● Synchronization detected error
0-1	Green	Off	Channel not configured
		On	The analog/digital converter is running, value is available

TM5SAI2L Characteristics

Introduction

This is the description characteristics for **TM5SAI2L** electronic module.

See also Environmental Characteristics (see page 23).

DANGER

FIRE HAZARD

Use only the recommended wire sizes for I/O channels and power supplies.

Failure to follow these instructions will result in death or serious injury.

WARNING

UNINTENDED EQUIPMENT OPERATION

Do not exceed any of the rated values specified in the following tables.

Failure to follow these instructions can result in death, serious injury, or equipment damage.

General Characteristics

The table below describes the general characteristics of the TM5SAI2L electronic module:

General Characteristics	
Rated power supply voltage Power supply source	24 Vdc Connected to the 24 Vdc I/O power segment
Power supply range	20.4...28.8 Vdc
24 Vdc I/O segment current draw	33 mA
TM5 Bus 5 Vdc current draw	2 mA
Power dissipation	0.81 W max.
Weight	25 g (0.9 oz)
Id code for firmware update	7070 dec

Input Characteristics

The table below describes the input characteristics of the TM5SAI2L electronic module:

Input Characteristics	Voltage Input	Current Input
Input range	-10...+10 Vdc	0...20 mA / 4...20 mA
Input impedance	20 MΩ min.	-
Load impedance	-	400 Ω max.
Sample duration time	300 μs for all inputs without filtering 1 ms for all inputs with filtering	
Input type	Differential	
Conversion mode	Successive Approximative Register	
Input filter	Low pass 3rd order / cut-off frequency 1 kHz	
Input tolerance - maximum deviation at ambient 25° C (77°F)	< 0.08% of the measurement	< 0.08% of the measurement
Input tolerance - temperature drift	0.006% / °C of the measurement	0.009% / °C of the measurement
Input tolerance - non linearity	< 0.025% of the full scale (20 Vdc)	< 0.05% of the full scale (20 mA)
Digital resolution	12 bits + sign	12 bits
Resolution value	2.441 mV	4.883 μA
Common mode rejection	DC	70 dB min.
	50 Hz	70 dB min.
Noise resistance - cable	Shielded cable is necessary	
Crosstalk rejection between channels	70 dB min.	
Isolation between channels	Not isolated	
Isolation between channels and bus	See note ¹ .	
Permitted input signal	±30 Vdc max.	±50 mA max.
Input protection	Protection against wiring with 24 Vdc supply voltage	
Common mode voltage allowable between channels	±12 Vdc max.	

¹ The isolation of the electronic module is 500 Vac RMS between the electronics power by the TM5 bus and those powered by 24 Vdc I/O power segment connected to the module. In practice, the TM5 electronic module is installed in the bus base, and there is a bridge between the TM5 power bus and the 24 Vdc I/O power segment. The two power circuits reference the same functional ground (FE) through specific components designed to reduce effects of electromagnetic interference. These components are rated at 30 Vdc or 60 Vdc. This effectively reduces isolation of the entire system from the 500 Vac RMS.

TM5SAI2L Wiring Diagram

Wiring Diagram

The following figure shows the wiring diagram for TM5SAI2L:

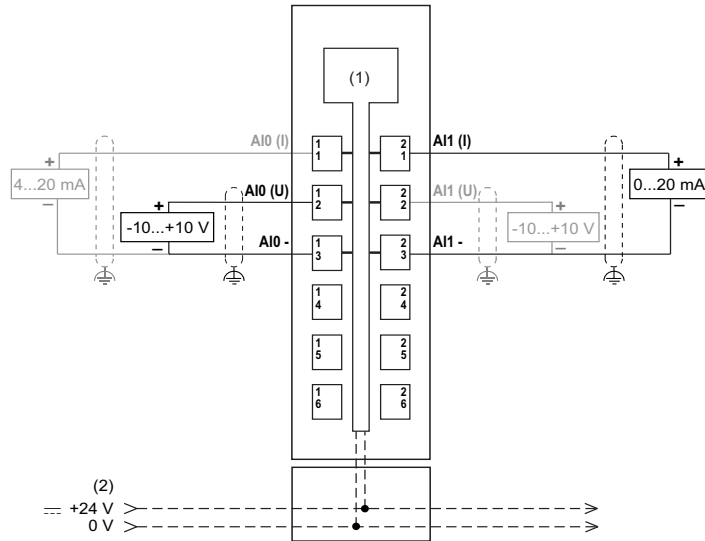

(1): Internal electronics

(2): 24 Vdc I/O power segment integrated into the bus bases

(I): Current

(U): Voltage

Use shielded, properly grounded cables for all analog and high-speed inputs or outputs and communication connections. If you do not use shielded cable for these connections, electromagnetic interference can cause signal degradation. Degraded signals can cause the controller or attached modules and equipment to perform in an unintended manner.

 WARNING

UNINTENDED EQUIPMENT OPERATION

- Use shielded cables wherever specified for inputs, outputs and communication connections.
- Properly ground the cable shields as indicated in the related documentation.
- Route communication and I/O cables separately from power cables.

Failure to follow these instructions can result in death, serious injury, or equipment damage.

 WARNING

UNINTENDED EQUIPMENT OPERATION

Do not connect wires to unused terminals or terminals marked “Not Connected (N.C.)”.

Failure to follow these instructions can result in death, serious injury, or equipment damage.

If you have physically wired, for example, your analog module channel for a voltage signal, and you configure the channel for a current signal in SoMachine, you may damage the analog module.

NOTICE

INOPERABLE EQUIPMENT

Be sure that the physical wiring of the module is compatible with the software configuration for the module.

Failure to follow these instructions can result in equipment damage.

3.2 TM5SAI4L Electronic Module 4AI $\pm 10V/0-20mA/4-20mA$ 12 Bits

What's in this Section?

This section contains the following topics:

Topic	Page
TM5SAI4L Presentation	50
TM5SAI4L Characteristics	52
TM5SAI4L Wiring Diagram	54

TM5SAI4L Presentation

Main Characteristics

The table below describes the main characteristics of the TM5SAI4L electronic module:

Main Characteristics		
Number of input channels	4	
Signal type	Voltage	Current
Input range	-10...+10 Vdc	0...20 mA / 4...20 mA
Resolution	12 bits + sign	12 bits

Ordering Information

The following figure shows the slice with a TM5SAI4L:



The table below shows the model numbers for the terminal block and bus base associated to TM5SAI4L:

Number	Model Number	Description	Color
1	TM5ACBM11	Bus base	White
	or TM5ACBM15	Bus base with address setting	White
2	TM5ASAI4L	Electronic module	White
3	TM5ACTB12	Terminal block, 12 pins	White

NOTE: For more information, refer to *TM5 bus bases and terminal blocks* (see *Modicon TM5 / TM7 Flexible System, System Planning and Installation Guide*)

Status LEDs

The following figure shows the TM5SAI4L status LEDs:

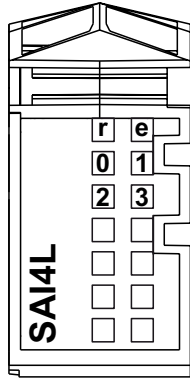

The table below shows the TM5SAI4L status LEDs:

LEDs	Color	Status	Description
r	Green	Off	No power supply
		Single Flash	Reset state
		Flashing	Preoperational state
		On	Normal operation
e	Red	Off	OK or no power supply
		On	Detected error or reset state
		Double Flash	System detected error: <ul style="list-style-type: none"> ● Scan time overrun ● Synchronization detected error
0-3	Green	Off	Channel not configured
		On	The analog/digital converter is running, value is available

TM5SAI4L Characteristics

Introduction

This is the description characteristics for TM5SAI4L electronic module.
See also Environmental Characteristics (see page 23).

 DANGER
<p>FIRE HAZARD</p> <p>Use only the recommended wire sizes for I/O channels and power supplies.</p> <p>Failure to follow these instructions will result in death or serious injury.</p>

 WARNING
<p>UNINTENDED EQUIPMENT OPERATION</p> <p>Do not exceed any of the rated values specified in the following tables.</p> <p>Failure to follow these instructions can result in death, serious injury, or equipment damage.</p>

General Characteristics

The table below describes the general characteristics of the TM5SAI4L electronic module:

General Characteristics	
Rated power supply voltage Power supply source	24 Vdc Connected to the 24 Vdc I/O power segment
Power supply range	20.4...28.8 Vdc
24 Vdc I/O segment current draw	46 mA
TM5 Bus 5 Vdc current draw	2 mA
Power dissipation	1.11 W max.
Weight	25 g (0.9 oz)
Id code for firmware update	7082 dec

Input Characteristics

The table below describes the input characteristics of the TM5SAI4L electronic module:

Input Characteristics	Voltage Input	Current Input
Input range	-10...+10 Vdc	0...20 mA / 4...20 mA
Input impedance	20 M Ω min.	-
Load impedance	-	400 Ω max.
Sample duration time	400 μ s for all inputs without filtering 1 ms for all inputs with filtering	
Input type	Differential	
Conversion mode	Successive Approximative Register	
Input filter	Low pass 3rd order / cut-off frequency 1 kHz	
Input tolerance - maximum deviation at ambient 25° C (77°F)	< 0.08% of the measurement	< 0.08% of the measurement
Input tolerance - temperature drift	0.006% / °C of the measurement	0.009% / °C of the measurement
Input tolerance - non linearity	< 0.025% of the full scale (20 Vdc)	< 0.05% of the full scale (20 mA)
Digital resolution	12 bits + sign	12 bits
Resolution value	2.441 mV	4.883 μ A
Common mode rejection	DC	70 dB min.
	50 Hz	70 dB min.
Noise resistance - cable	Shielded cable is necessary	
Crosstalk rejection between channels	70 dB min.	
Isolation between channels	Not isolated	
Isolation between channels and bus	See note ¹ .	
Permitted input signal	\pm 30 Vdc max.	\pm 50 mA max.
Input protection	Protection against wiring with 24 Vdc supply voltage	
Common mode voltage allowable between channels	\pm 12 Vdc max.	

¹ The isolation of the electronic module is 500 Vac RMS between the electronics power by the TM5 bus and those powered by 24 Vdc I/O power segment connected to the module. In practice, the TM5 electronic module is installed in the bus base, and there is a bridge between the TM5 power bus and the 24 Vdc I/O power segment. The two power circuits reference the same functional ground (FE) through specific components designed to reduce effects of electromagnetic interference. These components are rated at 30 Vdc or 60 Vdc. This effectively reduces isolation of the entire system from the 500 Vac RMS.

⚠ WARNING**UNINTENDED EQUIPMENT OPERATION**

- Use shielded cables wherever specified for inputs, outputs and communication connections.
- Properly ground the cable shields as indicated in the related documentation.
- Route communication and I/O cables separately from power cables.

Failure to follow these instructions can result in death, serious injury, or equipment damage.

⚠ WARNING**UNINTENDED EQUIPMENT OPERATION**

Do not connect wires to unused terminals or terminals marked “Not Connected (N.C.)”.

Failure to follow these instructions can result in death, serious injury, or equipment damage.

If you have physically wired, for example, your analog module channel for a voltage signal, and you configure the channel for a current signal in SoMachine, you may damage the analog module.

NOTICE**INOPERABLE EQUIPMENT**

Be sure that the physical wiring of the module is compatible with the software configuration for the module.

Failure to follow these instructions can result in equipment damage.

TM5SAI•H Analog 16 Bits Input Electronic Module



4

What's in this Chapter?

This chapter contains the following sections:

Section	Topic	Page
4.1	TM5SAI2H Electronic Module 2AI $\pm 10V/0-20mA$ 16 Bits	58
4.2	TM5SAI4H Electronic Module 4AI $\pm 10V/0-20mA$ 16 Bits	66

4.1 **TM5SAI2H Electronic Module 2AI $\pm 10V/0-20mA$ 16 Bits**

What's in this Section?

This section contains the following topics:

Topic	Page
TM5SAI2H Presentation	59
TM5SAI2H Characteristics	61
TM5SAI2H Wiring Diagram	63

TM5SAI2H Presentation

Main Characteristics

The table below describes the main characteristics of the TM5SAI2H electronic module:

Main Characteristics		
Number of input channels	2	
Signal type	Voltage	Current
Input range	-10...+10 Vdc	0...20 mA
Resolution	15 bits + sign	15 bits

Ordering Information

The following figure shows the slice with a TM5SAI2H:

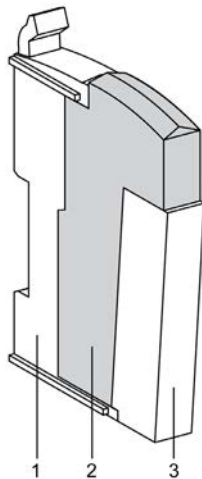

The table below shows the model numbers for the terminal block and bus base associated to TM5SAI2H:

Number	Model Number	Description	Color
1	TM5ACBM11	Bus base	White
	or TM5ACBM15	Bus base with address setting	White
2	TM5ASAI2H	Electronic module	White

Number	Model Number	Description	Color
3	TM5ACTB06	Terminal block, 6 pins	White
	or TM5ACTB12	Terminal block, 12 pins	White

NOTE: For more information, refer to *TM5 bus bases and terminal blocks* (see *Modicon TM5 / TM7 Flexible System, System Planning and Installation Guide*)

Status LEDs

The following figure shows the TM5SAI2H status LEDs:

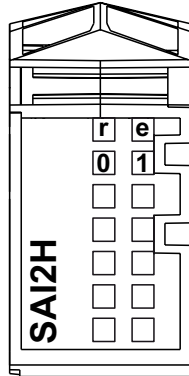

The table below shows the TM5SAI2H status LEDs:

LEDs	Color	Status	Description
r	Green	Off	No power supply
		Single Flash	Reset state
		Flashing	Preoperational state
		On	Normal operation
e	Red	Off	OK or no power supply
		On	Detected error or reset state
		Double Flash	System detected error: <ul style="list-style-type: none"> ● Scan time overrun ● Synchronization detected error
0-1	Green	Off	Channel not configured
		On	The analog/digital converter is running, value is available

TM5SAI2H Characteristics

Introduction

This is the description characteristics for **TM5SAI2H** electronic module.

See also Environmental Characteristics (*see page 23*).

DANGER

FIRE HAZARD

Use only the recommended wire sizes for I/O channels and power supplies.

Failure to follow these instructions will result in death or serious injury.

WARNING

UNINTENDED EQUIPMENT OPERATION

Do not exceed any of the rated values specified in the following tables.

Failure to follow these instructions can result in death, serious injury, or equipment damage.

General Characteristics

The table below describes the general characteristics of the TM5SAI2H electronic module:

General Characteristics	
Rated power supply voltage Power supply source	24 Vdc Connected to the 24 Vdc I/O power segment
Power supply range	20.4...28.8 Vdc
24 Vdc I/O segment current draw	50 mA
TM5 Bus 5 Vdc current draw	2 mA
Power dissipation	1.21 W max.
Weight	25 g (0.9 oz)
Id code for firmware update	7072 dec

Input Characteristics

The table below describes the input characteristics of the TM5SAI2H electronic module:

Input Characteristics	Voltage Input	Current Input
Input range	-10...+10 Vdc	0...20 mA
Input impedance	20 M Ω min.	-
Load impedance	-	400 Ω max.
Sample duration time	50 μ s for all inputs	
Input type	Differential	
Conversion mode	Successive Approximative Register	
Input filter	Low pass 3rd order / cut-off frequency 10 kHz	
Input tolerance - maximum deviation at ambient 25°C (77°F)	< 0.08% of the measurement	
Input tolerance - temperature drift	0.01% / °C of the measurement	
Input tolerance - non linearity	< 0.01% of the full scale (20 Vdc)	< 0.015% of the full scale (20 mA)
Digital resolution	15 bits + sign	15 bits
Resolution value	305.176 μ V	610.352 nA
Common mode rejection	DC	70 dB min.
	50 Hz	70 dB min.
Noise resistance - cable	Shielded cable is necessary	
Crosstalk rejection between channels	70 dB min.	
Isolation between channels	Not isolated	
Isolation between channels and bus	See note ¹ .	
Permitted input signal	\pm 30 Vdc max.	\pm 50 mA max.
Input protection	Protection against wiring with 24 Vdc supply voltage	
Common mode voltage allowable between channels	\pm 12 Vdc max.	

¹ The isolation of the electronic module is 500 Vac RMS between the electronics power by the TM5 bus and those powered by 24 Vdc I/O power segment connected to the module. In practice, the TM5 electronic module is installed in the bus base, and there is a bridge between the TM5 power bus and the 24 Vdc I/O power segment. The two power circuits reference the same functional ground (FE) through specific components designed to reduce effects of electromagnetic interference. These components are rated at 30 Vdc or 60 Vdc. This effectively reduces isolation of the entire system from the 500 Vac RMS.

TM5SAI2H Wiring Diagram

Wiring Diagram

The following figure shows the wiring diagram for TM5SAI2H:

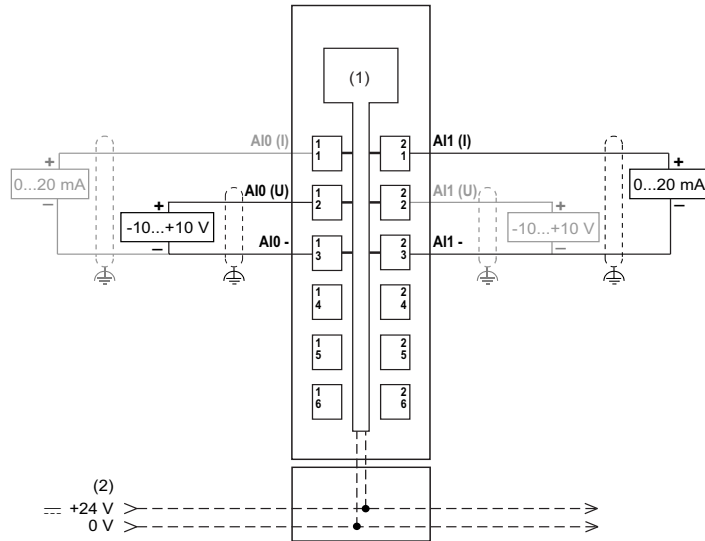

(1): Internal electronics

(2): 24 Vdc I/O power segment integrated into the bus bases

(I): Current

(U): Voltage

Use shielded, properly grounded cables for all analog and high-speed inputs or outputs and communication connections. If you do not use shielded cable for these connections, electromagnetic interference can cause signal degradation. Degraded signals can cause the controller or attached modules and equipment to perform in an unintended manner.

WARNING

UNINTENDED EQUIPMENT OPERATION

- Use shielded cables wherever specified for inputs, outputs and communication connections.
- Properly ground the cable shields as indicated in the related documentation.
- Route communication and I/O cables separately from power cables.

Failure to follow these instructions can result in death, serious injury, or equipment damage.

WARNING

UNINTENDED EQUIPMENT OPERATION

Do not connect wires to unused terminals or terminals marked “Not Connected (N.C.)”.

Failure to follow these instructions can result in death, serious injury, or equipment damage.

If you have physically wired, for example, your analog module channel for a voltage signal, and you configure the channel for a current signal in SoMachine, you may damage the analog module.

NOTICE

INOPERABLE EQUIPMENT

Be sure that the physical wiring of the module is compatible with the software configuration for the module.

Failure to follow these instructions can result in equipment damage.

Condition of Installation

Do not place 16-bit analog input modules side-by-side because their electromagnetic characteristics may lead to mutual interference and possible unintended equipment operation. Further, other types of equipments can generate similar electromagnetic interference affecting the conversion accuracy of the modules. In the physical configuration, a single slice of non-interfering equipment is sufficient to avoid this type of disturbance. Separate the 16-bit analog modules from each other and from the following equipment:

- TM5SBER2 Bus receiver
- TM5SPS2 and TM5SPS2F Power Distribution Modules
- TM258*** and LMC058*** Controllers

WARNING

UNINTENDED EQUIPMENT OPERATION

- Do not place 16_bit analog input modules next to each other.
- Do not place 16_bit analog input modules in direct proximity to equipment that generates electromagnetic interference.
- Insert at least one none interfering slice between any 16-bit analog input modules and any interference generating equipment.

Failure to follow these instructions can result in death, serious injury, or equipment damage.

4.2 **TM5SAI4H Electronic Module 4AI $\pm 10V/0-20mA$ 16 Bits**

What's in this Section?

This section contains the following topics:

Topic	Page
TM5SAI4H Presentation	67
TM5SAI4H Characteristics	69
TM5SAI4H Wiring Diagram	72

TM5SAI4H Presentation

Main Characteristics

The table below describes the main characteristics of the TM5SAI4H electronic module:

Main Characteristics		
Number of input channels	4	
Signal type	Voltage	Current
Input range	-10...+10 Vdc	0...20 mA
Resolution	15 bits + sign	15 bits

Ordering Information

The following figure shows the slice with a TM5SAI4H:

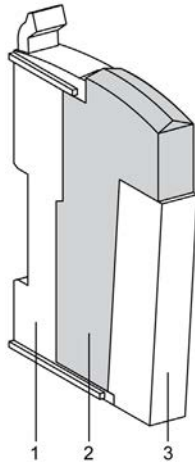

The table below shows the model numbers for the terminal block and bus base associated to TM5SAI4H:

Number	Model Number	Description	Color
1	TM5ACBM11	Bus base	White
	or TM5ACBM15	Bus base with address setting	White
2	TM5ASAI4H	Electronic module	White
3	TM5ACTB12	Terminal block, 12 pins	White

NOTE: For more information, refer to *TM5 bus bases and terminal blocks* (see *Modicon TM5 / TM7 Flexible System, System Planning and Installation Guide*)

Status LEDs

The following figure shows the LEDs for TM5SAI4H:

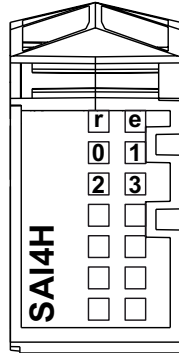

The table below shows the TM5SAI4H status LEDs:

LEDs	Color	Status	Description
r	Green	Off	No power supply
		Single Flash	Reset state
		Flashing	Preoperational state
		On	Normal operation
e	Red	Off	OK or no power supply
		On	Detected error or reset state
		Double Flash	System detected error: <ul style="list-style-type: none"> ● Scan time overrun ● Synchronization detected error
0-3	Green	Off	Channel not configured
		On	The analog/digital converter is running, value is available

TM5SAI4H Characteristics

Introduction

This is the description characteristics for **TM5SAI4H** electronic module.

See also Environmental Characteristics (*see page 23*).

DANGER

FIRE HAZARD

Use only the recommended wire sizes for I/O channels and power supplies.

Failure to follow these instructions will result in death or serious injury.

WARNING

UNINTENDED EQUIPMENT OPERATION

Do not exceed any of the rated values specified in the following tables.

Failure to follow these instructions can result in death, serious injury, or equipment damage.

General Characteristics

The table below describes the general characteristics of the TM5SAI4H electronic module:

General Characteristics	
Rated power supply voltage Power supply source	24 Vdc Connected to the 24 Vdc I/O power segment
Power supply range	20.4...28.8 Vdc
24 Vdc I/O segment current draw	63 mA
TM5 Bus 5 Vdc current draw	2 mA
Power dissipation	1.51 W max.
Weight	25 g (0.9 oz)
Id code for firmware update	7073 dec.

Input Characteristics

The table below describes the input characteristics of the TM5SAI4H electronic module:

Input Characteristics	Voltage Input	Current Input
Input range	-10...+10 Vdc	0...20 mA
Input impedance	20 M Ω min.	-
Load impedance	-	400 Ω max.
Sample duration time	50 μ s for all inputs	
Input type	Differential	
Conversion mode	Successive Approximative Register	
Input filter	Low pass 3rd order / cut-off frequency 10 kHz	
Input tolerance - maximum deviation at ambient 25°C (77°F)	< 0.08% of the measurement	
Input tolerance - temperature drift	0.01% / °C of the measurement	
Input tolerance - non linearity	< 0.01% of the full scale (20 Vdc)	< 0.015% of the full scale (20 mA)
De-rating *	See note *	
Digital resolution	15 bits + sign	15 bits
Resolution value	305.176 μ V	610.352 nA
Common mode rejection	DC	70 dB min.
	50 Hz	70 dB min.
Noise resistance - cable	Shielded cable is necessary	
Crosstalk rejection between channels	70 dB min.	
Isolation between channels	Not isolated	
Isolation between channels and bus	See note ¹ .	
* Note: These analog electronic modules are subject to operating temperature restrictions between 55 and 60 °C (131 and 140 °F). If the ambient temperature of your installation may exceed 55 °C (131 °F), do not install the TM5SAI-H modules adjacent to other devices capable of dissipating more than 1.15 W. For more information refer to <i>Enclosing the TM5 System (see Modicon TM5 / TM7 Flexible System, System Planning and Installation Guide)</i> .		

Input Characteristics	Voltage Input	Current Input
Permitted input signal	±30 Vdc max.	±50 mA max.
Input protection	Protection against wiring with 24 Vdc supply voltage	
Common mode voltage allowable between channels	±12 Vdc max.	
<p>* Note: These analog electronic modules are subject to operating temperature restrictions between 55 and 60 °C (131 and 140 °F). If the ambient temperature of your installation may exceed 55 °C (131 °F), do not install the TM5SAI-H modules adjacent to other devices capable of dissipating more than 1.15 W. For more information refer to <i>Enclosing the TM5 System (see Modicon TM5 / TM7 Flexible System, System Planning and Installation Guide)</i>.</p>		

¹ The isolation of the electronic module is 500 Vac RMS between the electronics power by the TM5 bus and those powered by 24 Vdc I/O power segment connected to the module. In practice, the TM5 electronic module is installed in the bus base, and there is a bridge between the TM5 power bus and the 24 Vdc I/O power segment. The two power circuits reference the same functional ground (FE) through specific components designed to reduce effects of electromagnetic interference. These components are rated at 30 Vdc or 60 Vdc. This effectively reduces isolation of the entire system from the 500 Vac RMS.

TM5SAI4H Wiring Diagram

Wiring Diagram

The following figure shows the wiring diagram for the TM5SAI4H:

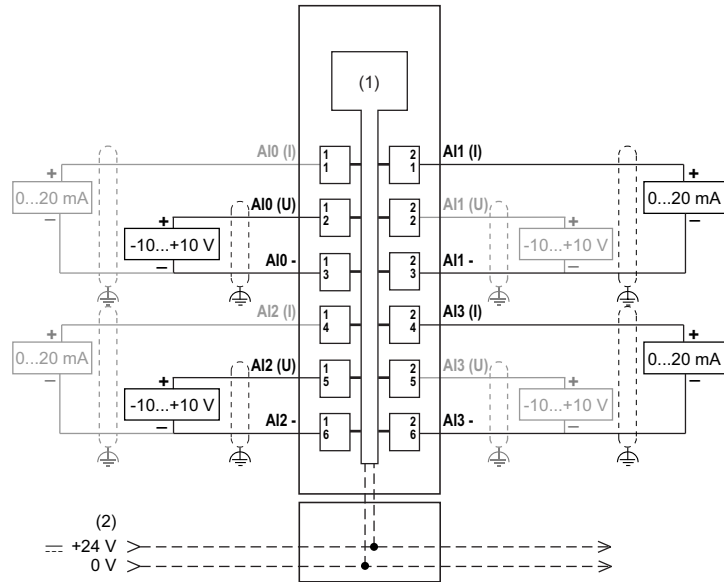

- 1 Internal electronics
- 2 24 Vdc I/O power segment integrated into the bus bases
- I Current
- U Voltage

Use shielded, properly grounded cables for all analog and high-speed inputs or outputs and communication connections. If you do not use shielded cable for these connections, electromagnetic interference can cause signal degradation. Degraded signals can cause the controller or attached modules and equipment to perform in an unintended manner.

⚠ WARNING**UNINTENDED EQUIPMENT OPERATION**

- Use shielded cables wherever specified for inputs, outputs and communication connections.
- Properly ground the cable shields as indicated in the related documentation.
- Route communication and I/O cables separately from power cables.

Failure to follow these instructions can result in death, serious injury, or equipment damage.

⚠ WARNING**UNINTENDED EQUIPMENT OPERATION**

Do not connect wires to unused terminals or terminals marked “Not Connected (N.C.)”.

Failure to follow these instructions can result in death, serious injury, or equipment damage.

If you have physically wired, for example, your analog module channel for a voltage signal, and you configure the channel for a current signal in SoMachine, you may damage the analog module.

NOTICE**INOPERABLE EQUIPMENT**

Be sure that the physical wiring of the module is compatible with the software configuration for the module.

Failure to follow these instructions can result in equipment damage.

Condition of Installation

Do not place 16-bit analog input modules side-by-side because their electromagnetic characteristics may lead to mutual interference and possible unintended equipment operation. Further, other types of equipments can generate similar electromagnetic interference affecting the conversion accuracy of the modules. In the physical configuration, a single slice of non-interfering equipment is sufficient to avoid this type of disturbance. Separate the 16-bit analog modules from each other and from the following equipment:

- TM5SBER2 Bus receiver
- TM5SPS2 and TM5SPS2F Power Distribution Modules
- TM258*** and LMC058*** Controllers:

 WARNING
UNINTENDED EQUIPMENT OPERATION
<ul style="list-style-type: none">● Do not place 16-bit analog input modules next to each other.● Do not place 16-bit analog input modules in direct proximity to equipment that generate electromagnetic interference.● Insert at least one non-interfering slice between any 16-bit analog input module and any interference generating equipment.
Failure to follow these instructions can result in death, serious injury, or equipment damage.

TM5SAI•PH Analog 16 Bits Temperature Input Electronic Module PT100/PT1000



5

What's in this Chapter?

This chapter contains the following sections:

Section	Topic	Page
5.1	TM5SAI2PH Electronic Module 2AI PT100/PT1000 16 Bits	76
5.2	TM5SAI4PH Electronic Module 4AI PT100/PT1000 16 Bits	84

5.1 **TM5SAI2PH Electronic Module 2AI PT100/PT1000 16 Bits**

What's in this Section?

This section contains the following topics:

Topic	Page
TM5SAI2PH Presentation	77
TM5SAI2PH Characteristics	79
TM5SAI2PH Wiring Diagram	81

TM5SAI2PH Presentation

Main Characteristics

The table below describes the main characteristics of the TM5SAI2PH electronic module:

Main Characteristics		
Number of input channels	2	
Measurement type	Temperature	Resistance
Input sensor type	PT100 or PT1000	-
Input range	-200°C...850°C	0.1 Ω...4500 Ω / 0.05 Ω...2250 Ω
Resolution	16-bit	

Ordering Information

The following figure shows the slice with a TM5SAI2PH:

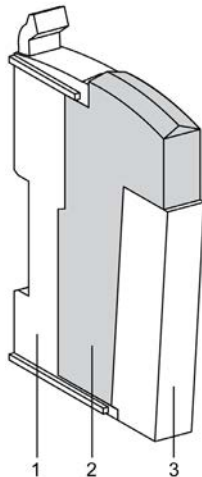

The table below shows the model numbers for the terminal block and bus base associated to TM5SAI2PH:

Number	Model Number	Description	Color
1	TM5ACBM11	Bus base	White
	or TM5ACBM15	Bus base with address setting	White
2	TM5SAI2PH	Electronic module	White

Number	Model Number	Description	Color
3	TM5ACTB06	Terminal block, 6 pins	White
	or TM5ACTB12	Terminal block, 12 pins	White

NOTE: For more information, refer to *TM5 bus bases and terminal blocks* (see *Modicon TM5 / TM7 Flexible System, System Planning and Installation Guide*)

Status LEDs

The following figure shows the LEDs for TM5SAI2PH:

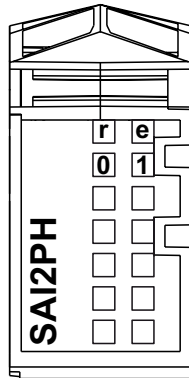

The table below shows the TM5SAI2PH status LEDs:

LEDs	Color	Status	Description
r	Green	Off	No power supply
		Single Flash	Reset state
		Flashing	Preoperational state
		On	Normal operation
e	Red	Off	OK or no power supply
		On	Detected error or reset state
		Single Flash	Detected error for an I/O channel.
e+r	Steady Red / Single Green Flash		Invalid firmware
0-1	Green	Off	Channel not configured
		Flashing	Overflow, underflow or broken wire detected
		On	The analog/digital converter is running, value is available

TM5SAI2PH Characteristics

Introduction

This is the description characteristics for **TM5SAI2PH** electronic module.

See also **Environmental Specifications** (see page 23).

⚠ WARNING
UNINTENDED EQUIPMENT OPERATION
Do not exceed any of the rated values specified in the following tables.
Failure to follow these instructions can result in death, serious injury, or equipment damage.

General Characteristics

The table below describes the general characteristics of the TM5SAI2PH electronic module:

General Characteristics	
Rated power supply voltage Power supply source	24 Vdc Connected to the 24 Vdc I/O power segment
Power supply range	20.4...28.8 Vdc
24 Vdc I/O segment current draw	46 mA
TM5 Bus 5 Vdc current draw	2 mA
Power dissipation	1.11 W max.
Weight	25 g (0.9 oz)
Id code for firmware update	7078 dec

Input Characteristics

The table below describes the input characteristics of the TM5SAI2PH electronic module:

Input Characteristics	
Input sensor type	PT100/PT1000
Input temperature range	PT100: -200...850°C (-328...1562°F) PT1000: -200...850°C (-328...1562°F)
Resistance measurement range	1st mode: 0.1...4500 Ω 2nd mode: 0.05...2250 Ω
Measuring current	250 μA ± 1.25%

Input Characteristics		
Sample duration time		See Cycle Time and I/O Update Time (see <i>Modicon TM5, Expansion Modules Configuration, Programming Guide</i>)
Wiring type		2-wire or 3-wire connection configured by software for all inputs
Conversion mode		Sigma delta type
Input filter		Low pass 1st order / cut-off frequency 500 Hz
Input tolerance - maximum deviation at ambient 25°C (77°F)		0.037% of the measurement
Input tolerance - temperature drift		0.004% / °C of the measurement
Input tolerance - non linearity		0.0010% of the entire resistance range
Digital resolution		16-bit
Resolution temperature value		PT1000: 0.1°C (0.18°F)
		PT100: 0.1°C (0.18°F)
Resolution resistance value		1st mode: 0.1 Ω 2nd mode: 0.05 Ω
Common mode rejection	DC	95 dB min.
	50 Hz	80 dB min.
Noise resistance - cable		Shielded cable is necessary
Crosstalk rejection between channels		93 dB min.
Isolation between channels		Not isolated
Isolation between channels and bus		See note ¹ .
Permitted input signal		±30 Vdc max.
Input protection		Protection against wiring with 24 Vdc supply voltage
Common mode voltage allowable between channels		2 Vdc max.

¹ The isolation of the electronic module is 500 Vac RMS between the electronics power by the TM5 bus and those powered by 24 Vdc I/O power segment connected to the module. In practice, the TM5 electronic module is installed in the bus base, and there is a bridge between the TM5 power bus and the 24 Vdc I/O power segment. The two power circuits reference the same functional ground (FE) through specific components designed to reduce effects of electromagnetic interference. These components are rated at 30 Vdc or 60 Vdc. This effectively reduces isolation of the entire system from the 500 Vac RMS.

TM5SAI2PH Wiring Diagram

Wiring Diagram

The following figure shows the 2-wire wiring diagram of TM5SAI2PH:

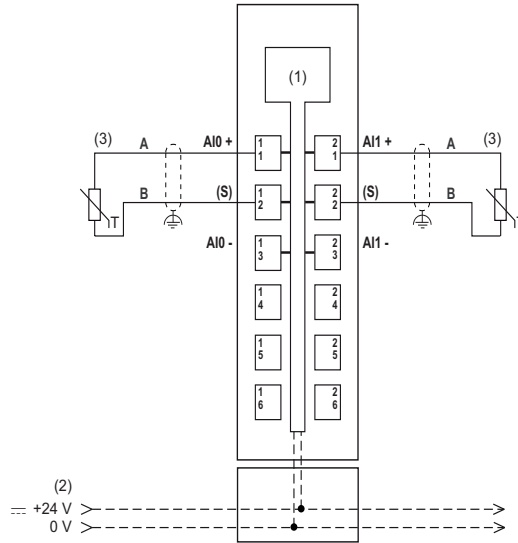

- (1):** Internal electronics
- (2):** 24 Vdc I/O power segment integrated into the bus bases
- (3):** 2-wire sensor
- (S):** Sensor

The following figure shows the 3-wire and 4-wire wiring diagram for TM5SAI2PH:

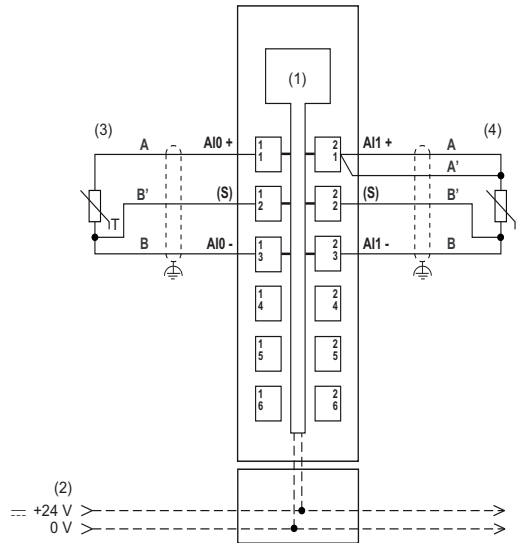

- (1): Internal electronics
- (2): 24 Vdc I/O power segment integrated into the bus bases
- (3): 3-wire sensor
- (4): 4-wire sensor
- (S): Sensor

Use shielded, properly grounded cables for all analog and high-speed inputs or outputs and communication connections. If you do not use shielded cable for these connections, electromagnetic interference can cause signal degradation. Degraded signals can cause the controller or attached modules and equipment to perform in an unintended manner.

⚠ WARNING

UNINTENDED EQUIPMENT OPERATION

- Use shielded cables wherever specified for inputs, outputs and communication connections.
- Properly ground the cable shields as indicated in the related documentation.
- Route communication and I/O cables separately from power cables.

Failure to follow these instructions can result in death, serious injury, or equipment damage.

 WARNING

UNINTENDED EQUIPMENT OPERATION

Do not connect wires to unused terminals or terminals marked “Not Connected (N.C.)”.

Failure to follow these instructions can result in death, serious injury, or equipment damage.

If you have physically wired, for example, your analog module channel for a voltage signal, and you configure the channel for a current signal in SoMachine, you may damage the analog module.

NOTICE

INOPERABLE EQUIPMENT

Be sure that the physical wiring of the module is compatible with the software configuration for the module.

Failure to follow these instructions can result in equipment damage.

5.2 **TM5SAI4PH Electronic Module 4AI PT100/PT1000 16 Bits**

What's in this Section?

This section contains the following topics:

Topic	Page
TM5SAI4PH Presentation	85
TM5SAI4PH Characteristics	87
TM5SAI4PH Wiring Diagram	89

TM5SAI4PH Presentation

Main Characteristics

The table below describes the main characteristics of the TM5SAI4PH electronic module:

Main Characteristics		
Number of input channels	4	
Measurement type	Temperature	Resistance
Input sensor type	PT100 or PT1000	-
Input range	-200.0°C...850.0°C	0.1 Ω...4500.0 Ω / 0.05 Ω...2250.0 Ω
Resolution	16-bit	

Ordering Information

The following figure shows the slice with a TM5SAI4PH:

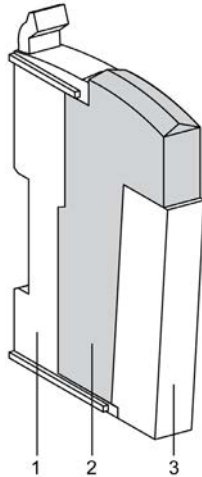

The table below shows the model numbers for the terminal block and bus base associated to TM5SAI4PH:

Number	Model Number	Description	Color
1	TM5ACBM11 or TM5ACBM15	Bus base	White
		Bus base with address setting	White
2	TM5SAI4PH	Electronic module	White

Number	Model Number	Description	Color
3	TM5ACTB12	Terminal block, 12 pins	White

NOTE: For more information, refer to *TM5 bus bases and terminal blocks* (see *Modicon TM5 / TM7 Flexible System, System Planning and Installation Guide*)

Status LEDs

The following figure shows the TM5SAI4PH status LEDs:

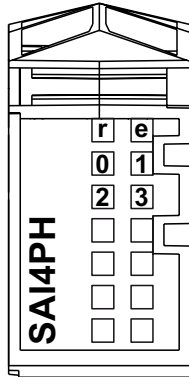

The table below shows the TM5SAI4PH status LEDs:

LEDs	Color	Status	Description
r	Green	Off	No power supply
		Single Flash	Reset state
		Flashing	Preoperational state
		On	Normal operation
e	Red	Off	OK or no power supply
		On	Detected error or reset state
		Single Flash	Detected error for an I/O channel.
e+r	Steady Red / Single Green Flash		Invalid firmware
0-3	Green	Off	Channel not configured
		Flashing	Overflow, underflow or broken wire detected
		On	The analog/digital converter is running, value is available

TM5SAI4PH Characteristics

Introduction

This is the description characteristics for **TM5SAI4PH** electronic module.

See also **Environmental Specifications** (*see page 23*).

 WARNING
UNINTENDED EQUIPMENT OPERATION
Do not exceed any of the rated values specified in the following tables.
Failure to follow these instructions can result in death, serious injury, or equipment damage.

General Characteristics

The table below describes the general characteristics of the TM5SAI4PH electronic module:

General Characteristics	
Rated power supply voltage Power supply source	24 Vdc Connected to the 24 Vdc I/O power segment
Power supply range	20.4...28.8 Vdc
24 Vdc I/O segment current draw	46 mA
TM5 Bus 5 Vdc current draw	2 mA
Power dissipation	1.11 W max.
Weight	25 g (0.9 oz)
Id code for firmware update	7079 dec

Input Characteristics

The table below describes the input characteristics of the TM5SAI4PH electronic module:

Input Characteristics	
Input sensor type	PT100/PT1000
Input temperature range	PT100: -200...850°C (-328...1562°F) PT1000: -200...850°C (-328...1562°F)
Resistance measurement range	1st mode: 0.1...4500 Ω 2nd mode: 0.05...2250 Ω
Measuring current	250 μA ± 1.25%

Input Characteristics		
Sample duration time		See Cycle Time and I/O Update Time (see <i>Modicon TM5, Expansion Modules Configuration, Programming Guide</i>)
Wiring type		2-wire or 3-wire connection configured by software for all inputs
Conversion mode		Sigma delta type
Input filter		Low pass 1st order / cut-off frequency 500 Hz
Input tolerance - maximum deviation at ambient 25°C (77°F)		0.037% of the measurement
Input tolerance - temperature drift		0.004% / °C of the measurement
Input tolerance - non linearity		0.001% of the entire resistance range
Digital resolution		16-bit
Resolution temperature value		PT1000: 0.1°C (0.18°F)
		PT100: 0.1°C (0.18°F)
Resolution resistance value		1st mode: 0.1 Ω 2nd mode: 0.05 Ω
Common mode rejection	DC	95 dB min.
	50 Hz	80 dB min.
Noise resistance - cable		Shielded cable is necessary
Crosstalk rejection between channels		93 dB min.
Isolation between channels		Not isolated
Isolation between channels and bus		See note ¹ .
Permitted input signal		±30 Vdc max.
Input protection		Protection against wiring with 24 Vdc supply voltage
Common mode voltage allowable between channels		2 Vdc max.

¹ The isolation of the electronic module is 500 Vac RMS between the electronics power by the TM5 bus and those powered by 24 Vdc I/O power segment connected to the module. In practice, the TM5 electronic module is installed in the bus base, and there is a bridge between the TM5 power bus and the 24 Vdc I/O power segment. The two power circuits reference the same functional ground (FE) through specific components designed to reduce effects of electromagnetic interference. These components are rated at 30 Vdc or 60 Vdc. This effectively reduces isolation of the entire system from the 500 Vac RMS.

TM5SAI4PH Wiring Diagram

Wiring Diagram

The following figure shows the 2-wire wiring diagram of TM5SAI4PH:

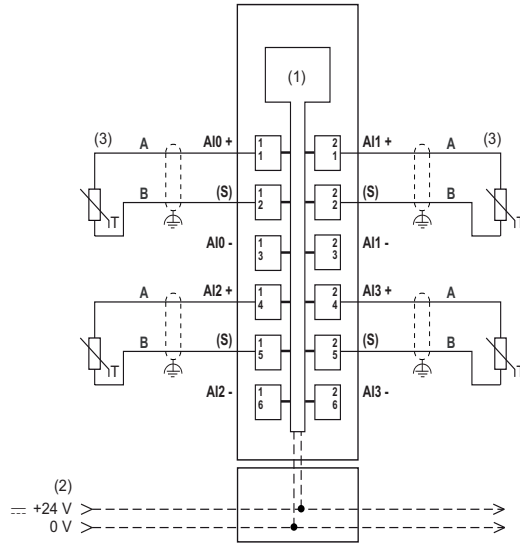

- (1):** Internal electronics
- (2):** 24 Vdc I/O power segment integrated into the bus bases
- (3):** 2-wire sensor
- (S):** Sensor

The following figure shows the 3-wire and 4-wire wiring diagram of TM5SAI4PH:

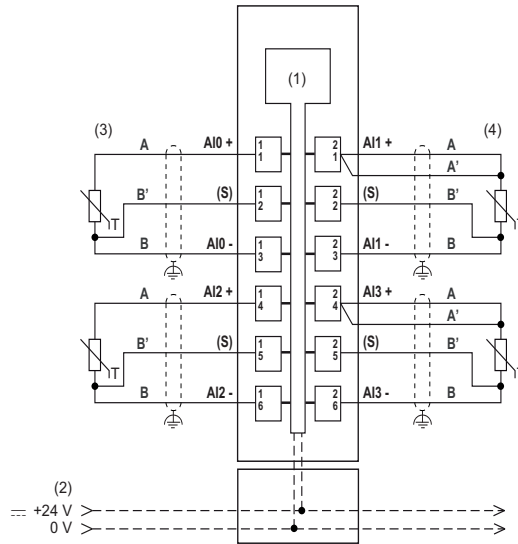

- (1): Internal electronics
- (2): 24 Vdc I/O power segment integrated into the bus bases
- (3): 3-wire sensor
- (4): 4-wire sensor
- (S): Sensor

Use shielded, properly grounded cables for all analog and high-speed inputs or outputs and communication connections. If you do not use shielded cable for these connections, electromagnetic interference can cause signal degradation. Degraded signals can cause the controller or attached modules and equipment to perform in an unintended manner.

⚠ WARNING

UNINTENDED EQUIPMENT OPERATION

- Use shielded cables wherever specified for inputs, outputs and communication connections.
- Properly ground the cable shields as indicated in the related documentation.
- Route communication and I/O cables separately from power cables.

Failure to follow these instructions can result in death, serious injury, or equipment damage.

 WARNING

UNINTENDED EQUIPMENT OPERATION

Do not connect wires to unused terminals or terminals marked “Not Connected (N.C.)”.

Failure to follow these instructions can result in death, serious injury, or equipment damage.

If you have physically wired, for example, your analog module channel for a voltage signal, and you configure the channel for a current signal in SoMachine, you may damage the analog module.

NOTICE

INOPERABLE EQUIPMENT

Be sure that the physical wiring of the module is compatible with the software configuration for the module.

Failure to follow these instructions can result in equipment damage.

TM5SAI•TH Analog 16 Bits Temperature Input Electronic Module Thermocouple J/K/N/S

6

What's in this Chapter?

This chapter contains the following sections:

Section	Topic	Page
6.1	TM5SAI2TH Electronic Module 2AI Thermocouple J/K/N/S 16 Bits	94
6.2	TM5SAI6TH Electronic Module 6AI Thermocouple J/K/N/S 16 Bits	103

6.1 **TM5SAI2TH Electronic Module 2AI Thermocouple J/K/N/S 16 Bits**

What's in this Section?

This section contains the following topics:

Topic	Page
TM5SAI2TH Presentation	95
TM5SAI2TH Characteristics	98
TM5SAI2TH Wiring Diagram	100

TM5SAI2TH Presentation

Main Characteristics

The table below describes the main characteristics of the TM5SAI2TH module:

Main Characteristics		
Number of input channels	2	
Measurement type	Temperature	Voltage
Input sensor type	J, K, N and S thermocouple sensors	
Input range	Type J: -210...1200°C (-346...2192°F) Type K: -270...1372°C (-454...2501°F) Type N: -270...1300°C (-454...2372°F) Type S: -50...1768°C (-58...3214°F)	± 65.534 mV
Resolution	16-bit	

The thermocouple modules are configured as a whole for the same type of thermocouple sensor. You cannot mix thermocouple sensor types on the same module, otherwise the temperature readings will not be correct.

WARNING

UNINTENDED EQUIPMENT OPERATION

- Only connect thermocouple sensors of the same type to the temperature module.
- Configure the module for the correct type of thermocouple.

Failure to follow these instructions can result in death, serious injury, or equipment damage.

Ordering Information

The following figure shows the slice with a TM5SAI2TH:

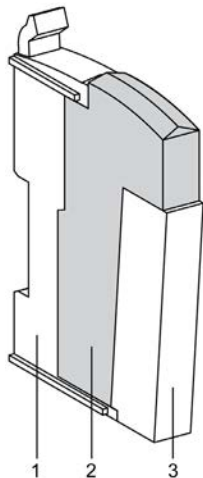

The table below shows the model numbers for the terminal block and bus base associated to TM5SAI2TH:

Number	Model Number	Description	Color
1	TM5ACBM11	Bus base	White
	or TM5ACBM15	Bus base with address setting	White
2	TM5ASAI2TH	Electronic module	White
3	TM5ACTB06	Terminal block, 6 pins	White
	or TM5ACTB12	Terminal block, 12 pins	White

NOTE: For more information, refer to *TM5 bus bases and terminal blocks* (see *Modicon TM5 / TM7 Flexible System, System Planning and Installation Guide*)

Status LEDs

The following figure shows the TM5SAI2TH status LEDs:

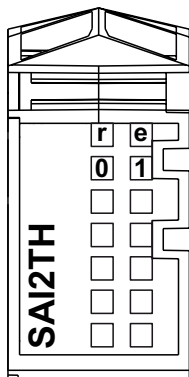

The table below shows the TM5SAI2TH status LEDs:

LEDs	Color	Status	Description
r	Green	Off	No power supply
		Single Flash	Reset state
		Flashing	Preoperational state
		On	Normal operation
e	Red	Off	OK or no power supply
		On	Detected error or reset state
		Single Flash	Detected error for an I/O channel.
e+r	Steady Red / Single Green Flash		Invalid firmware
0-1	Green	Off	Channel not configured
		Flashing	Overflow, underflow or broken wire detected
		On	The analog/digital converter is running, value is available

TM5SAI2TH Characteristics

Introduction

This is the description characteristics for **TM5SAI2TH** electronic module.
See also Environmental Characteristics (see page 23).

⚠ WARNING
UNINTENDED EQUIPMENT OPERATION
Do not exceed any of the rated values specified in the following tables.
Failure to follow these instructions can result in death, serious injury, or equipment damage.

General Characteristics

The table below describes the general characteristics of the TM5SAI2TH electronic module:

General Characteristics	
Rated power supply voltage Power supply source	24 Vdc Connected to the 24 Vdc I/O power segment
Power supply range	20.4...28.8 Vdc
24 Vdc I/O segment current draw	30 mA
TM5 Bus 5 Vdc current draw	2 mA
Power dissipation	0.73 W max.
Weight	25 g (0.9 oz)
Id code for firmware update	7080 dec

Input Characteristics

The table below describes the input characteristics of the TM5SAI2TH electronic module:

Input Characteristics	
Input sensor type	Thermocouple
Input temperature range	Type J: -210...1200°C (-346...2192°F) Type K: -270...1372°C (-454...2501°F) Type N: -270...1300°C (-454...2372°F) Type S: -50...1768°C (-58...3214°F)
Input voltage range	± 65.534 mV

Input Characteristics		
Sample duration time	See Cycle Time and I/O Update Time (see <i>Modicon TM5, Expansion Modules Configuration, Programming Guide</i>)	
Conversion mode	Sigma delta type	
Input filter	Low pass 1st order / cut-off frequency 500 Hz	
Input time	1...66.7 ms configurable by software	
Input tolerance - maximum deviation at ambient 25°C (77°F)	Type J: $\pm 0.10\%$ of the measurement Type K: $\pm 0.11\%$ of the measurement Type N: $\pm 0.11\%$ of the measurement Type S: $\pm 0.17\%$ of the measurement	
Input tolerance - temperature drift	0.01% / °C of the measurement	
Input tolerance - non linearity	$\pm 0.001\%$ of the entire measurement range	
Input tolerance - terminal temperature compensation	$\pm 5^\circ\text{C}$ after 10 min	
Digital resolution	16-bit	
Resolution temperature value	0.1°C (0.18°F)	
Common mode rejection	DC	70 dB min.
	50 Hz	70 dB min.
Noise resistance - cable	Shielded cable is necessary	
Crosstalk rejection between channels	70 dB min.	
Isolation between channels	Not isolated	
Isolation between channels and bus	See note ¹ .	
Permitted input signal	± 5 Vdc max.	
Input protection	Protection against wiring with 24 Vdc supply voltage	
Common mode voltage allowable between channels	± 15 Vdc max.	

¹ The isolation of the electronic module is 500 Vac RMS between the electronics power by the TM5 bus and those powered by 24 Vdc I/O power segment connected to the module. In practice, the TM5 electronic module is installed in the bus base, and there is a bridge between the TM5 power bus and the 24 Vdc I/O power segment. The two power circuits reference the same functional ground (FE) through specific components designed to reduce effects of electromagnetic interference. These components are rated at 30 Vdc or 60 Vdc. This effectively reduces isolation of the entire system from the 500 Vac RMS.

TM5SAI2TH Wiring Diagram

Wiring Diagram

The following figure shows the wiring diagram for TM5SAI2TH:

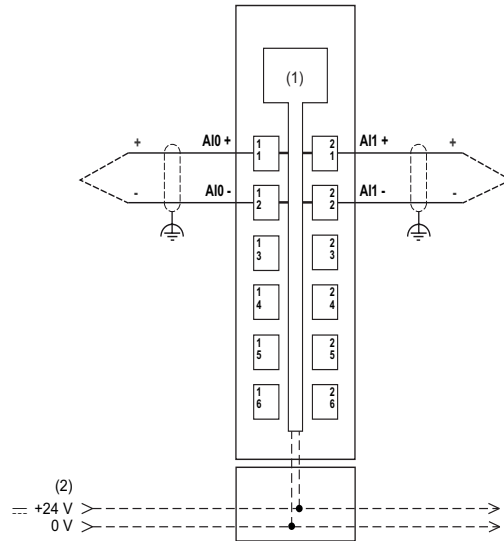

(1): Internal electronics

(2): 24 Vdc I/O power segment integrated into the bus bases

Use shielded, properly grounded cables for all analog and high-speed inputs or outputs and communication connections. If you do not use shielded cable for these connections, electromagnetic interference can cause signal degradation. Degraded signals can cause the controller or attached modules and equipment to perform in an unintended manner.

⚠ WARNING

UNINTENDED EQUIPMENT OPERATION

- Use shielded cables wherever specified for inputs, outputs and communication connections.
- Properly ground the cable shields as indicated in the related documentation.
- Route communication and I/O cables separately from power cables.

Failure to follow these instructions can result in death, serious injury, or equipment damage.

 WARNING

UNINTENDED EQUIPMENT OPERATION

Do not connect wires to unused terminals or terminals marked “Not Connected (N.C.)”.

Failure to follow these instructions can result in death, serious injury, or equipment damage.

Ceramic Heating Element with Integrated Thermo Elements

Ripple voltage effects can potentially cause measurement errors.

 WARNING

RIPPLE VOLTAGE CAN CAUSE UNINTENDED EQUIPMENT OPERATION

Connect the negative input of the thermocouple element to the negative input of the power distribution module (PDM).

Failure to follow these instructions can result in death, serious injury, or equipment damage.

The following figure shows the wiring diagram for TM5SAI2TH with a PDM:

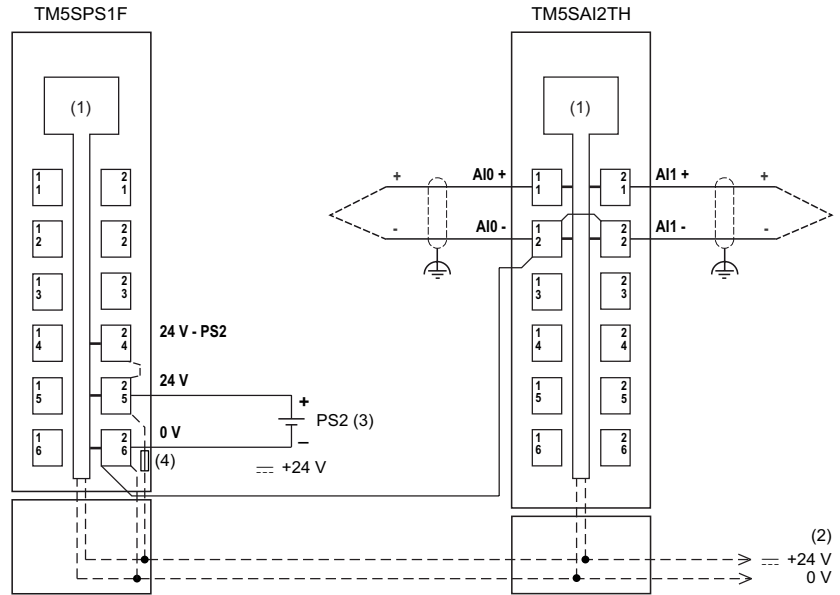

- (1): Internal electronics
- (2): 24 Vdc I/O power segment integrated into the bus bases
- (3): PS2: External isolated power supply 24 Vdc
- (4): Integrated fuse type T slow-blow 6.3 A 250 V exchangeable

6.2 TM5SAI6TH Electronic Module 6AI Thermocouple J/K/N/S 16 Bits

What's in this Section?

This section contains the following topics:

Topic	Page
TM5SAI6TH Presentation	104
TM5SAI6TH Characteristics	107
TM5SAI6TH Wiring Diagram	109

TM5SAI6TH Presentation

Main Characteristics

The table below describes the main characteristics of the TM5SAI6TH module:

Main Characteristics		
Number of input channels	6	
Measurement type	Temperature	Voltage
Input sensor type	J, K, N and S thermocouple sensors	
Input range	Type J: -210...1200°C (-346...2192°F) Type K: -270...1372°C (-454...2501°F) Type N: -270...1300°C (-454...2372°F) Type S: -50...1768°C (-58...3214°F)	± 65.534 mV
Resolution	16-bit	

The thermocouple modules are configured as a whole for the same type of thermocouple sensor. You cannot mix thermocouple sensor types on the same module, otherwise the temperature readings will not be correct.

WARNING

UNINTENDED EQUIPMENT OPERATION

- Only connect thermocouple sensors of the same type to the temperature module.
- Configure the module for the correct type of thermocouple.

Failure to follow these instructions can result in death, serious injury, or equipment damage.

Ordering Information

The following figure shows the slice with a TM5SAI6TH:

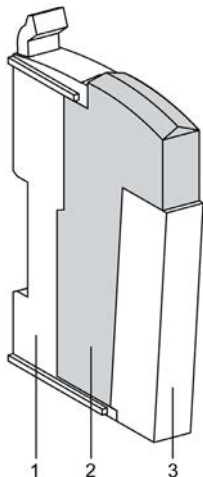

The table below shows the model numbers for the terminal block and bus base associated to TM5SAI6TH:

Number	Model Number	Description	Color
1	TM5ACBM11 or TM5ACBM15	Bus base Bus base with address setting	White
2	TM5SAI6TH	Electronic module	White
3	TM5ACTB12	Terminal block, 12 pins	White

NOTE: For more information, refer to *TM5 bus bases and terminal blocks* (see *Modicon TM5 / TM7 Flexible System, System Planning and Installation Guide*)

Status LEDs

The following figure shows the TM5SAI6TH status LEDs:

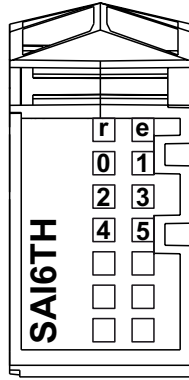

The table below shows the TM5SAI6TH status LEDs:

LEDs	Color	Status	Description
r	Green	Off	No power supply
		Single Flash	Reset state
		Flashing	Preoperational state
		On	Normal operation
e	Red	Off	OK or no power supply
		On	Detected error or reset state
		Single Flash	Detected error for an I/O channel.
e+r	Steady Red / Single Green Flash		Invalid firmware
0-5	Green	Off	Channel not configured
		Flashing	Overflow, underflow or broken wire detected
		On	The analog/digital converter is running, value is available

TM5SAI6TH Characteristics

Introduction

This is the description characteristics for **TM5SA6TH** electronic module.

See also Environmental Characteristics (see page 23).

WARNING

UNINTENDED EQUIPMENT OPERATION

Do not exceed any of the rated values specified in the following tables.

Failure to follow these instructions can result in death, serious injury, or equipment damage.

General Characteristics

The table below describes the general characteristics of the TM5SAI6TH electronic module:

General Characteristics	
Rated power supply voltage Power supply source	24 Vdc Connected to the 24 Vdc I/O power segment
Power supply range	20.4...28.8 Vdc
24 Vdc I/O segment current draw	38 mA
TM5 Bus 5 Vdc current draw	2 mA
Power dissipation	0.92 W max.
Weight	25 g (0.9 oz)
Id code for firmware update	7081 dec

Input Characteristics

The table below describes the input characteristics of the TM5SAI6TH electronic module:

Input Characteristics	
Input sensor type	Thermocouple
Input temperature range	Type J: -210...1200°C (-346...2192°F) Type K: -270...1372°C (-454...2501°F) Type N: -270...1300°C (-454...2372°F) Type S: -50...1768°C (-58...3214°F)
Input voltage range	± 65.534 mV

Input Characteristics		
Sample duration time	See Cycle Time and I/O Update Time (see <i>Modicon TM5, Expansion Modules Configuration, Programming Guide</i>)	
Conversion mode	Sigma delta type	
Input filter	Low pass 1st order / cut-off frequency 500 Hz	
Input time	1...66.7 ms configurable by software	
Input tolerance - maximum deviation at ambient 25° C (77°F)	Type J: $\pm 0.10\%$ of the measurement Type K: $\pm 0.11\%$ of the measurement Type N: $\pm 0.11\%$ of the measurement Type S: $\pm 0.17\%$ of the measurement	
Input tolerance - temperature drift	0.01% / °C of the measurement	
Input tolerance - non linearity	$\pm 0.001\%$ of the entire measurement range	
Input tolerance - terminal temperature compensation	$\pm 5^\circ\text{C}$ after 10 min	
Digital resolution	16-bit	
Resolution temperature value	0.1°C (0.18°F)	
Common mode rejection	DC	70 dB min.
	50 Hz	70 dB min.
Noise resistance - cable	Shielded cable is necessary	
Crosstalk rejection between channels	70 dB min.	
Isolation between channels	Not isolated	
Isolation between channels and bus	See note ¹ .	
Permitted input signal	± 5 Vdc max.	
Input protection	Protection against wiring with 24 Vdc supply voltage.	
Common mode voltage allowable between channels	± 15 Vdc max.	

¹ The isolation of the electronic module is 500 Vac RMS between the electronics power by the TM5 bus and those powered by 24 Vdc I/O power segment connected to the module. In practice, the TM5 electronic module is installed in the bus base, and there is a bridge between the TM5 power bus and the 24 Vdc I/O power segment. The two power circuits reference the same functional ground (FE) through specific components designed to reduce effects of electromagnetic interference. These components are rated at 30 Vdc or 60 Vdc. This effectively reduces isolation of the entire system from the 500 Vac RMS.

TM5SAI6TH Wiring Diagram

Wiring Diagram

The following figure shows the wiring diagram for TM5SAI6TH:

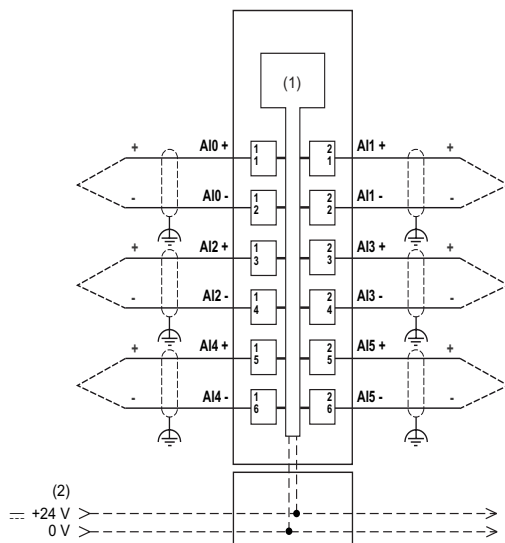

(1): Internal electronics

(2): 24 Vdc I/O power segment integrated into the bus bases

Use shielded, properly grounded cables for all analog and high-speed inputs or outputs and communication connections. If you do not use shielded cable for these connections, electromagnetic interference can cause signal degradation. Degraded signals can cause the controller or attached modules and equipment to perform in an unintended manner.

⚠ WARNING

UNINTENDED EQUIPMENT OPERATION

- Use shielded cables wherever specified for inputs, outputs and communication connections.
- Properly ground the cable shields as indicated in the related documentation.
- Route communication and I/O cables separately from power cables.

Failure to follow these instructions can result in death, serious injury, or equipment damage.

 WARNING

UNINTENDED EQUIPMENT OPERATION

Do not connect wires to unused terminals or terminals marked “Not Connected (N.C.)”.

Failure to follow these instructions can result in death, serious injury, or equipment damage.

Ceramic Heating Element with Integrated Thermo Elements

Ripple voltage effects can potentially cause measurement errors.

 WARNING

RIPPLE VOLTAGE CAN CAUSE UNINTENDED EQUIPMENT OPERATION

Connect the negative input of the thermocouple element to the negative input of the power distribution module (PDM).

Failure to follow these instructions can result in death, serious injury, or equipment damage.

The following figure shows the wiring diagram for TM5SAI6TH with a PDM:

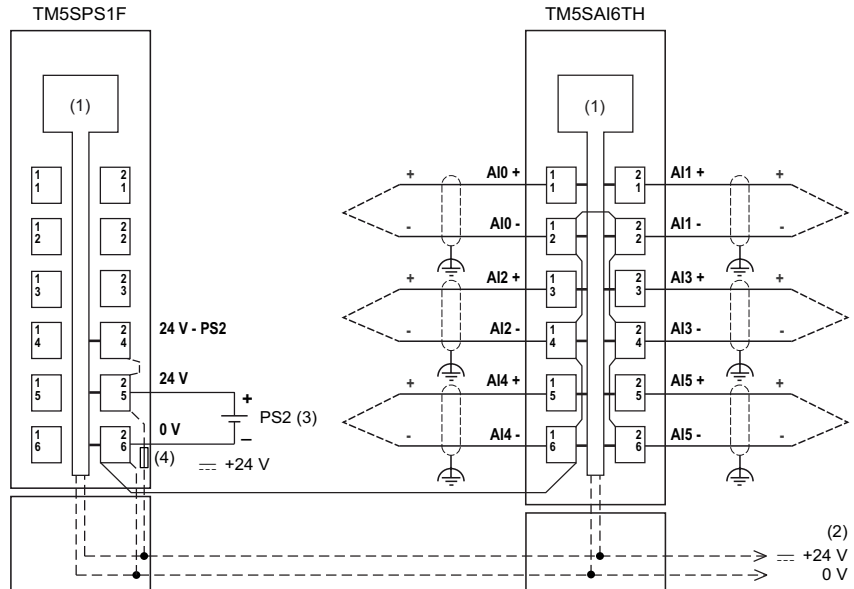

- (1): Internal electronics
- (2): 24 Vdc I/O power segment integrated into the bus bases
- (3): PS2: External isolated power supply 24 Vdc
- (4): Integrated fuse type T slow-blow 6.3 A 250 V exchangeable

TM5SEAISG Analog Strain Gauge Input Electronic Module

7

What's in this Chapter?

This chapter contains the following topics:

Topic	Page
TM5SEAISG Presentation	114
TM5SEAISG Characteristics	116
TM5SEAISG Wiring Diagram	119

TM5SEAI5G Presentation

Main Characteristics

The table below describes the main characteristics of the TM5SEAI5G module:

Main Characteristics	
Number of input channels	1
Measurement type	Full-bridge strain gauge
Sensor operating range	85...5000 Ω
Resolution	24-bit

For configuring and programming your TM5SEAI5G electronic module, refer to *IoDrvTM5SEAI5G Strain Gauge Library Guide* (see *Modicon TM5, IoDrvTM5SEAI5G Strain Gauge, Library Guide*).

Ordering Information

The following figure shows the slice with a TM5SEAI5G:

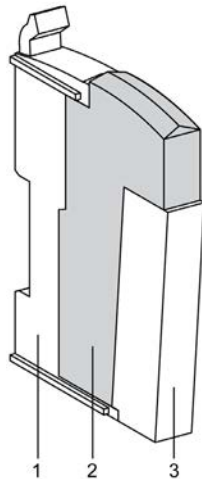

The table below shows the model numbers for the terminal block and bus base associated to TM5SEAI5G:

Number	Model Number	Description	Color
1	TM5ACBM11	Bus base	White
	or TM5ACBM15	Bus base with address setting	White
2	TM5SEAI5G	Electronic module	White

Number	Model Number	Description	Color
3	TM5ACTB12	Terminal block, 12 pins	White

NOTE: For more information, refer to *TM5 bus bases and terminal blocks* (see *Modicon TM5 / TM7 Flexible System, System Planning and Installation Guide*)

Status LEDs

The following figure shows the TM5SEAISG status LEDs:

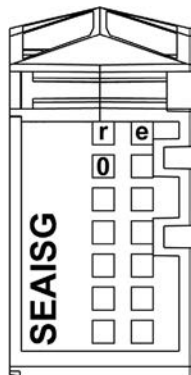

The table below shows the TM5SEAISG status LEDs:

LEDs	Color	Status	Description
r	Green	Off	No power supply
		Single Flash	Reset state
		Flashing	Preoperational state
		On	Normal operation
e	Red	Off	OK or no power supply
		On	Detected error or reset state
0	Green	Off	Broken wire detected The analog/digital converter is busy
		On	The analog/digital converter is running, value is available

TM5SEAISG Characteristics

Introduction

This is the description characteristics for the TM5SEAISG electronic module. See also Environmental Characteristics (see page 23)

⚠ DANGER
FIRE HAZARD
Use only the recommended wire sizes for I/O channels and power supplies.
Failure to follow these instructions will result in death or serious injury.

⚠ WARNING
UNINTENDED EQUIPMENT OPERATION
Do not exceed any of the rated values specified in the following tables.
Failure to follow these instructions can result in death, serious injury, or equipment damage.

General Characteristics

The table below describes the general characteristics of the TM5SEAISG electronic module:

General Characteristics	
Rated power supply voltage Power supply source	24 Vdc Connected to the 24 Vdc I/O power segment
Power supply range	20.4...28.8 Vdc
24 Vdc I/O segment current draw	52 mA
TM5 Bus 5 Vdc current draw	2 mA
Power dissipation	1.25 W max.
Weight	25 g (0.9 oz)
ID code for firmware update	7390 dec

Input Characteristics of Analog Channels

The table describes the input characteristics of analog channels of the TM5SEAISG electronic module:

Input Characteristics	Full-bridge Strain Gauge
Number of inputs	1
Bridge factor	+/- 2...+/- 256 mV/Vdc configurable using <code>ConfigOutput00</code> ADC configuration register. Refer to Expansion Bus I/O Mapping Tab (see <i>Modicon TM5, IoDrvTM5SEAISG Strain Gauge, Library Guide</i>).
Input type	Differential
Input current	690 nA
Sensor operating range	85...5000 Ω
Conversion time	Depends on the data output rate
Data output rate	2.5...7500 samples per second, configured by software
Conversion mode	Sigma delta type
Input filter	Third order / attenuation 60 dB / cut-off frequency 5 kHz
Input tolerance - temperature drift	10 ppm
Digital resolution	24 bits
Resolution	Refer to effective resolution of the strain gauge value in bits (see <i>Modicon TM5, IoDrvTM5SEAISG Strain Gauge, Library Guide</i>)
Wire	Shielded, twisted pair cable length < 30 m (98.42 ft) ¹
Input protection	Protection against wiring with 24 Vdc supply voltage
(1) The shielded, twisted pair cable should be as short as possible and run separately to the sensor (isolated from load circuit) without intermediate terminals.	

Full-bridge Strain Gauge Supply Characteristics

Full-bridge Supply Characteristics		
Number of full-bridge		4 max.
Wiring type		4 or 6 wires
Supply voltage		5.5 Vdc
Supply current		65 mA max.
Voltage drop		0.2 Vdc max. at 65 mA
Supply protection		Overload short-circuit
Isolation	Between input and internal bus	See note ¹
	Between supply and internal bus	See note ¹

¹ The isolation of the electronic module is 500 Vac RMS between the electronics power by the TM5 bus and those powered by 24 Vdc I/O power segment connected to the module. In practice, the TM5 electronic module is installed in the bus base, and there is a bridge between the TM5 power bus and the 24 Vdc I/O power segment. The two power circuits reference the same functional ground (FE) through specific components designed to reduce effects of electromagnetic interference. These components are rated at 30 Vdc or 60 Vdc. This effectively reduces isolation of the entire system from the 500 Vac RMS.

TM5SEAISG Wiring Diagram

Wiring Diagram

The following figure shows the wiring diagram for TM5SEAISG with a 6-wire full-bridge strain gauge:

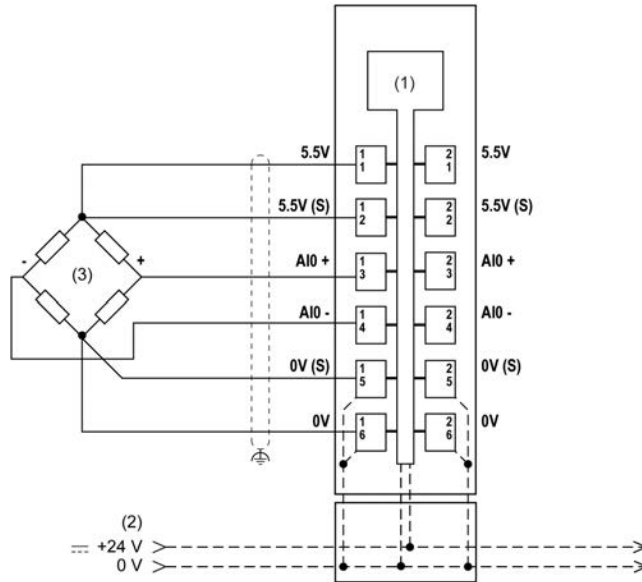

(1): Internal electronics

(2): 24 Vdc I/O power segment integrated into the bus bases

(3): 6-wire full-bridge strain gauge

(S): Sensor

NOTE: For parallel connection of full-bridge strain gauges, refer to the guidelines of the sensor manufacturer.

The following figure shows the wiring diagram for TM5SEAISG with two 4-wire full-bridge strain gauges:

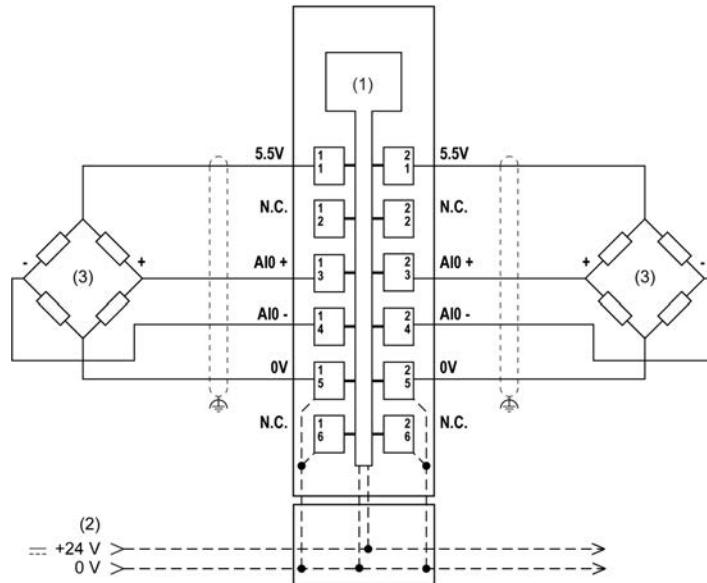

- (1): Internal electronics
- (2): 24 Vdc I/O power segment integrated into the bus bases
- (3): 4-wire full-bridge strain gauge

NOTE: For parallel connection of full-bridge strain gauges, refer to the guidelines of the sensor manufacturer.

Use shielded, properly grounded cables for all analog and high-speed inputs or outputs and communication connections. If you do not use shielded cable for these connections, electromagnetic interference can cause signal degradation. Degraded signals can cause the controller or attached modules and equipment to perform in an unintended manner.

⚠ WARNING

UNINTENDED EQUIPMENT OPERATION

- Use shielded cables wherever specified for inputs, outputs and communication connections.
- Properly ground the cable shields as indicated in the related documentation.
- Route communication and I/O cables separately from power cables.

Failure to follow these instructions can result in death, serious injury, or equipment damage.

 WARNING

UNINTENDED EQUIPMENT OPERATION

Do not connect wires to unused terminals or terminals marked “Not Connected (N.C.)”.

Failure to follow these instructions can result in death, serious injury, or equipment damage.

TM5 System Analog Output Electronic Modules

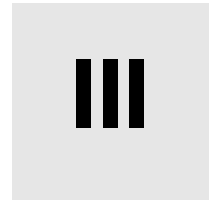

TM5SAO** Analog Output Electronic Module



8

What's in this Chapter?

This chapter contains the following sections:

Section	Topic	Page
8.1	TM5SAO2L Electronic Module 2AO $\pm 10V/0-20mA$ 12 Bits	126
8.2	TM5SAO4L Electronic Module 4AO $\pm 10V/0-20mA$ 12 Bits	133
8.3	TM5SAO2H Electronic Module 2AO $\pm 10V/0-20mA$ 16 Bits	142
8.4	TM5SAO4H Electronic Module 4AO $\pm 10V/0-20mA$ 16 Bits	149

8.1 **TM5SAO2L Electronic Module 2AO $\pm 10V/0-20mA$ 12 Bits**

What's in this Section?

This section contains the following topics:

Topic	Page
TM5SAO2L Presentation	127
TM5SAO2L Characteristics	129
TM5SAO2L Wiring Diagram	131

TM5SAO2L Presentation

Main Characteristics

The table below describes the main characteristics of the TM5SAO2L electronic module:

Main Characteristics		
Number of output channels	2	
Signal type	Voltage	Current
Output range	-10...+10 Vdc	0...20 mA
Resolution	12 bits + sign	12 bits

Ordering Information

The following figure shows the slice with a TM5SAO2L:

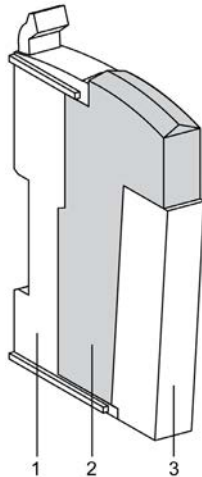

The table below shows the model numbers for the terminal block and bus base associated to TM5SAO2L:

Number	Model Number	Description	Color
1	TM5ACBM11 or TM5ACBM15	Bus base	White
		Bus base with address setting	White
2	TM5ASAO2L	Electronic module	White

Number	Model Number	Description	Color
3	TM5ACTB06	Terminal block, 6 pins	White
	or TM5ACTB12	Terminal block, 12 pins	White

NOTE: For more information, refer to *TM5 bus bases and terminal blocks* (see *Modicon TM5 / TM7 Flexible System, System Planning and Installation Guide*)

Status LEDs

The following figure shows the TM5SAO2L status LEDs:

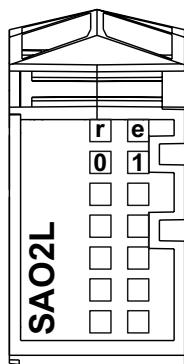

The table below shows the TM5SAO2L status LEDs:

LEDs	Color	Status	Description
r	Green	Off	No power supply
		Single Flash	Reset state
		Flashing	Preoperational state
		On	Normal operation
e	Red	Off	OK or no power supply
		On	Detected error or reset state
0-1	Yellow	Off	Value = 0
		On	Value ≠ 0

TM5SAO2L Characteristics

Introduction

This is the description characteristics for the **TM5SAO2L** electronic module.
See also Environmental Characteristics (*see page 23*).

DANGER

FIRE HAZARD

Use only the recommended wire sizes for I/O channels and power supplies.

Failure to follow these instructions will result in death or serious injury.

WARNING

UNINTENDED EQUIPMENT OPERATION

Do not exceed any of the rated values specified in the following tables.

Failure to follow these instructions can result in death, serious injury, or equipment damage.

General Characteristics

The table below describes the general characteristics of the TM5SAO2L electronic module:

General Characteristics	
Rated power supply voltage Power supply source	24 Vdc Connected to the 24 Vdc I/O power segment
Power supply range	20.4...28.8 Vdc
24 Vdc I/O segment current draw	46 mA
TM5 Bus 5 Vdc current draw	2 mA
Power dissipation	1.11 W max.
Weight	25 g (0.9 oz)
ID code for firmware update	7074 dec

Output Characteristics

The table below describes the output characteristics of the TM5SA02L electronic module:

Characteristic	Voltage Output	Current Output
Output range	-10...+10 Vdc	0...20 mA
Output impedance	1 kΩ min.	-
Load impedance	-	500 Ω max.
Sample duration time	200 μs for all outputs	
Output type	Differential	
Response time for output change	1 ms max.	
Output tolerance - maximum deviation at ambient 25° C (77° F)	< 0.15% of the measurement	
Output tolerance - temperature drift	0.02% / °C of the measurement	
Output tolerance - non linearity	< 0.007% of the full scale (20 Vdc)	< 0.007% of the full scale (20 mA)
Output tolerance - maximum deviation caused by load change	0.02% from 10 MΩ to 1 kΩ, resistive	0.5% from 1 Ω to 500 Ω, resistive
Digital resolution	12 bits + sign	12 bits
Resolution value	4.882 mV	9.766 μA
Noise resistance - cable	Shielded cable is necessary	
Isolation between channels	Not isolated	
Isolation between channels and bus	See note ¹ .	
Output protection	Short circuit protection: current limitation is 40 mA	

¹ The isolation of the electronic module is 500 Vac RMS between the electronics power by the TM5 bus and those powered by 24 Vdc I/O power segment connected to the module. In practice, the TM5 electronic module is installed in the bus base, and there is a bridge between the TM5 power bus and the 24 Vdc I/O power segment. The two power circuits reference the same functional ground (FE) through specific components designed to reduce effects of electromagnetic interference. These components are rated at 30 Vdc or 60 Vdc. This effectively reduces isolation of the entire system from the 500 Vac RMS.

TM5SAO2L Wiring Diagram

Wiring Diagram

The following figure shows the wiring diagram for TM5SAO2L:

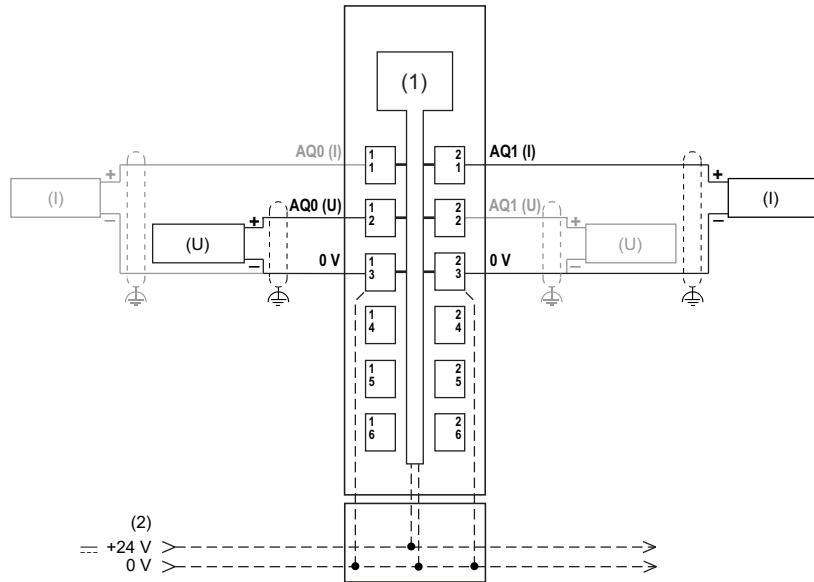

(1): Internal electronics

(2): 24 Vdc I/O power segment integrated into the bus bases

(I): Current

(U): Voltage

Use shielded, properly grounded cables for all analog and high-speed inputs or outputs and communication connections. If you do not use shielded cable for these connections, electromagnetic interference can cause signal degradation. Degraded signals can cause the controller or attached modules and equipment to perform in an unintended manner.

 WARNING

UNINTENDED EQUIPMENT OPERATION

- Use shielded cables wherever specified for inputs, outputs and communication connections.
- Properly ground the cable shields as indicated in the related documentation.
- Route communication and I/O cables separately from power cables.

Failure to follow these instructions can result in death, serious injury, or equipment damage.

 WARNING

UNINTENDED EQUIPMENT OPERATION

Do not connect wires to unused terminals or terminals marked "Not Connected (N.C.)".

Failure to follow these instructions can result in death, serious injury, or equipment damage.

8.2 TM5SAO4L Electronic Module 4AO $\pm 10V/0-20mA$ 12 Bits

What's in this Section?

This section contains the following topics:

Topic	Page
TM5SAO4L Presentation	134
TM5SAO4L Characteristics	136
TM5SAO4L Wiring Diagram	140

TM5SAO4L Presentation

Main Characteristics

The table below describes the main characteristics of the TM5SAO4L electronic module:

Main Characteristics		
Number of output channels	4	
Signal type	Voltage	Current
Output range	-10...+10 Vdc	0...20 mA
Resolution	12 bits + sign	12 bits

Ordering Information

The following figure shows the slice with a TM5SAO4L:

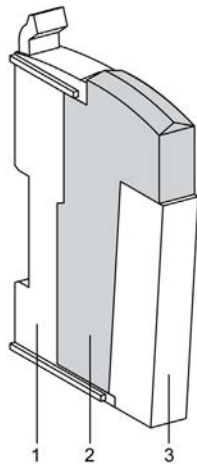

The table below shows the model numbers for the terminal block and bus base associated to TM5SAO4L:

Number	Model Number	Description	Color
1	TM5ACBM11	Bus base	White
	or TM5ACBM15	Bus base with address setting	White
2	TM5ASAO4L	Electronic module	White
3	TM5ACTB12	Terminal block, 12 pins	White

NOTE: For more information, refer to *TM5 bus bases and terminal blocks* (see *Modicon TM5 / TM7 Flexible System, System Planning and Installation Guide*)

Status LEDs

The following figure shows the TM5SAO4L status LEDs:

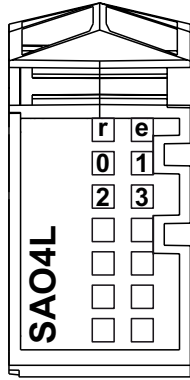

The table below shows the TM5SAO4L status LEDs:

LEDs	Color	Status	Description
r	Green	Off	No power supply
		Single Flash	Reset state
		Flashing	Preoperational state
		On	Normal operation
e	Red	Off	OK or no power supply
		On	Detected error or reset state
0-3	Yellow	Off	Value = 0
		On	Value ≠ 0

TM5SAO4L Characteristics

Introduction

This is the description characteristics for the **TM5SAO4L** electronic module.
See also Environmental Characteristics (*see page 23*).

⚠ DANGER
FIRE HAZARD
Use only the recommended wire sizes for I/O channels and power supplies.
Failure to follow these instructions will result in death or serious injury.

⚠ WARNING
UNINTENDED EQUIPMENT OPERATION
Do not exceed any of the rated values specified in the following tables.
Failure to follow these instructions can result in death, serious injury, or equipment damage.

General Characteristics

The table below describes the general characteristics of the TM5SA04L electronic module:

General Characteristics	
Rated power supply voltage Power supply source	24 Vdc Connected to the 24 Vdc I/O power segment
Power supply range	20.4...28.8 Vdc
24 Vdc I/O segment current draw	63 mA
TM5 Bus 5 Vdc current draw	2 mA
Power dissipation	1.51 W max.
Weight	25 g (0.9 oz)
ID code for firmware update	7075 dec

Output Characteristics

The table below describes the output characteristics of the TM5SA04L electronic module:

Characteristic	Voltage Output	Current Output
Output range	-10...+10 Vdc	0...20 mA
Output impedance	1 k Ω min.	-
Load impedance	-	200 Ω min. 500 Ω max.
Sample duration time	300 μ s for all outputs	
Output type	Differential	
Response time for output change	1 ms max.	
Output tolerance - maximum deviation at ambient 25° C (77° F)	< 0.08% of the measurement	
Output tolerance - temperature drift	0.015% / °C of the measurement	
Output tolerance - non linearity	< 0.005% of the full scale (20 Vdc)	< 0.005% of the full scale (20 mA)
De-rating *	See note *	
Output tolerance - maximum deviation caused by load change	0.02% from 10 M Ω to 1 k Ω , resistive	0.5% from 1 Ω to 500 Ω , resistive
Digital resolution	12 bits + sign	12 bits
Resolution value	4.882 mV	9.766 μ A
Noise resistance - cable	Shielded cable is necessary	
Isolation between channels	Not isolated	
Isolation between channels and bus	See note ¹ .	
Output protection	Short circuit protection: current limitation is 40 mA	
* Note: These analog electronic modules are subject to operating temperature restrictions between 55 and 60 °C (131 and 140 °F). If the ambient temperature of your installation may exceed 55 °C (131 °F), do not install the TM5SAI•H modules adjacent to other devices capable of dissipating more than 1.15 W. For more information refer to <i>Enclosing the TM5 System</i> (see <i>Modicon TM5 / TM7 Flexible System, System Planning and Installation Guide</i>).		

¹ The isolation of the electronic module is 500 Vac RMS between the electronics power by the TM5 bus and those powered by 24 Vdc I/O power segment connected to the module. In practice, the TM5 electronic module is installed in the bus base, and there is a bridge between the TM5 power bus and the 24 Vdc I/O power segment. The two power circuits reference the same functional ground (FE) through specific components designed to reduce effects of electromagnetic interference. These components are rated at 30 Vdc or 60 Vdc. This effectively reduces isolation of the entire system from the 500 Vac RMS.

De-rating the output load

The analog output modules can be configured as voltage outputs, current outputs, or a mix of voltage and current outputs. In the case of a mixed configuration, you must adjust the following de-rating information.

If only one of the outputs in the mix is configured as a current output, use the mean between the current and voltage curves. If more than one output in the mix is configured as a current output, use the current output de-rating curve. Otherwise, use the appropriate de-rating information as follows:

De-rating the voltage output load in a horizontal installation:

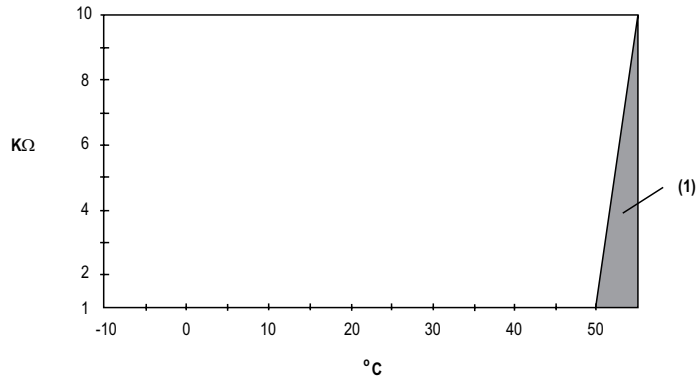

1 Invalid area

De-rating the current output load in a horizontal installation:

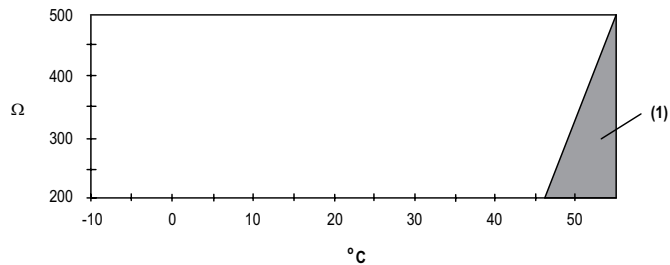

1 Invalid area

De-rating the voltage output load in a vertical installation:

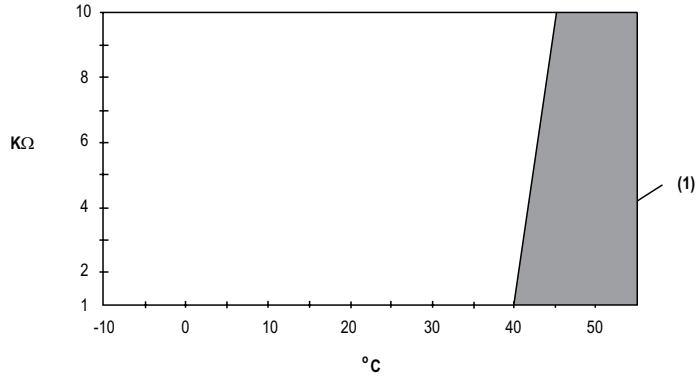

1 Invalid area

De-rating the current output load in a vertical installation:

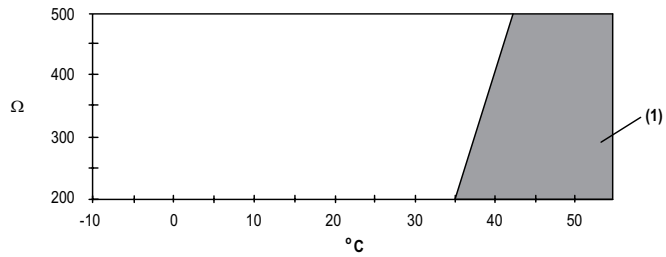

1 Invalid area

TM5SAO4L Wiring Diagram

Wiring Diagram

The following figure shows the wiring diagram for TM5SAO4L:

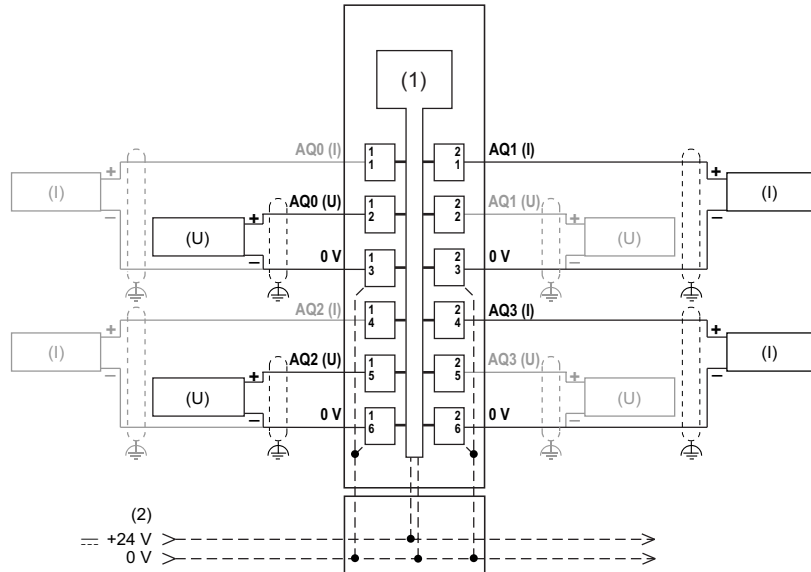

(1): Internal electronics

(2): 24 Vdc I/O power segment integrated into the bus bases

(I): Current

(U): Voltage

Use shielded, properly grounded cables for all analog and high-speed inputs or outputs and communication connections. If you do not use shielded cable for these connections, electromagnetic interference can cause signal degradation. Degraded signals can cause the controller or attached modules and equipment to perform in an unintended manner.

 WARNING

UNINTENDED EQUIPMENT OPERATION

- Use shielded cables wherever specified for inputs, outputs and communication connections.
- Properly ground the cable shields as indicated in the related documentation.
- Route communication and I/O cables separately from power cables.

Failure to follow these instructions can result in death, serious injury, or equipment damage.

 WARNING

UNINTENDED EQUIPMENT OPERATION

Do not connect wires to unused terminals or terminals marked "Not Connected (N.C.)".

Failure to follow these instructions can result in death, serious injury, or equipment damage.

8.3 TM5SAO2H Electronic Module 2AO $\pm 10V/0-20mA$ 16 Bits

What's in this Section?

This section contains the following topics:

Topic	Page
TM5SAO2H Presentation	143
TM5SAO2H Characteristics	145
TM5SAO2H Wiring Diagram	147

TM5SAO2H Presentation

Main Characteristics

The table below describes the main characteristics of the TM5SAO2H electronic module:

Main Characteristics		
Number of output channels	2	
Signal type	Voltage	Current
Output range	-10...+10 Vdc	0...20 mA
Resolution	15 bits + sign	15 bits

Ordering Information

The following figure shows the slice with a TM5SAO2H:

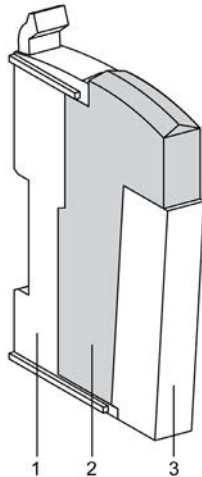

The table below shows the model numbers for the terminal block and bus base associated to TM5SAO2H:

Number	Model Number	Description	Color
1	TM5ACBM11	Bus base	White
	or TM5ACBM15	Bus base with address setting	White
2	TM5ASAO2H	Electronic module	White

Number	Model Number	Description	Color
3	TM5ACTB06	Terminal block, 6 pins	White
	or TM5ACTB12	Terminal block, 12 pins	White

NOTE: For more information, refer to *TM5 bus bases and terminal blocks* (see *Modicon TM5 / TM7 Flexible System, System Planning and Installation Guide*)

Status LEDs

The following figure shows the TM5SAO2H status LEDs:

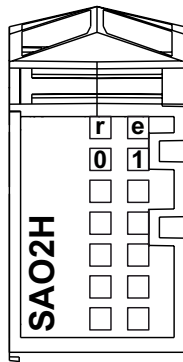

The table below shows the TM5SAO2H status LEDs:

LEDs	Color	Status	Description
r	Green	Off	No power supply
		Single Flash	Reset state
		Flashing	Preoperational state
		On	Normal operation
e	Red	Off	OK or no power supply
		On	Detected error or reset state
0-1	Yellow	Off	Value = 0
		On	Value ≠ 0

TM5SAO2H Characteristics

Introduction

This is the description characteristics for the **TM5SAO2H** electronic module.
See also Environmental Characteristics (*see page 23*).

DANGER

FIRE HAZARD

Use only the recommended wire sizes for I/O channels and power supplies.

Failure to follow these instructions will result in death or serious injury.

WARNING

UNINTENDED EQUIPMENT OPERATION

Do not exceed any of the rated values specified in the following tables.

Failure to follow these instructions can result in death, serious injury, or equipment damage.

General Characteristics

The table below describes the general characteristics of the TM5SAO2H electronic module:

General Characteristics	
Rated power supply voltage Power supply source	24 Vdc Connected to the 24 Vdc I/O power segment
Power supply range	20.4...28.8 Vdc
24 Vdc I/O segment current draw	50 mA
TM5 Bus 5 Vdc current draw	2 mA
Power dissipation	1.21 W max.
Weight	25 g (0.9 oz)
ID code for firmware update	7076 dec

Output Characteristics

The table below describes the output characteristics of the TM5SA02H electronic module:

Characteristic	Voltage Output	Current Output
Output range	-10...+10 Vdc	0...20 mA
Output impedance	1 k Ω min.	-
Load impedance	+/- 10 mA max	500 Ω max.
Sample duration time	50 μ s for all outputs	
Output type	Differential	
Response time for output change	1 ms max.	
Output tolerance - maximum deviation at ambient 25° C (77° F)	< 0.045% of the measurement	
Output tolerance - temperature drift	0.015% / °C of the measurement	
Output tolerance - non linearity	< 0.007% of the full scale (20 Vdc)	< 0.007% of the full scale (20 mA)
Output tolerance - maximum deviation caused by load change	0.02% from 10 M Ω to 1 k Ω , resistive	0.5% from 1 Ω to 500 Ω , resistive
Digital resolution	15 bits + sign	15 bits
Resolution value	305.176 μ V	610.352 nA
Noise resistance - cable	Shielded cable is necessary	
Isolation between channels	Not isolated	
Isolation between channels and bus	See note ¹ .	
Output protection	Short circuit protection: current limitation is 40 mA	

¹ The isolation of the electronic module is 500 Vac RMS between the electronics power by the TM5 bus and those powered by 24 Vdc I/O power segment connected to the module. In practice, the TM5 electronic module is installed in the bus base, and there is a bridge between the TM5 power bus and the 24 Vdc I/O power segment. The two power circuits reference the same functional ground (FE) through specific components designed to reduce effects of electromagnetic interference. These components are rated at 30 Vdc or 60 Vdc. This effectively reduces isolation of the entire system from the 500 Vac RMS.

TM5SAO2H Wiring Diagram

Wiring Diagram

The following figure shows the wiring diagram for TM5SAO2H:

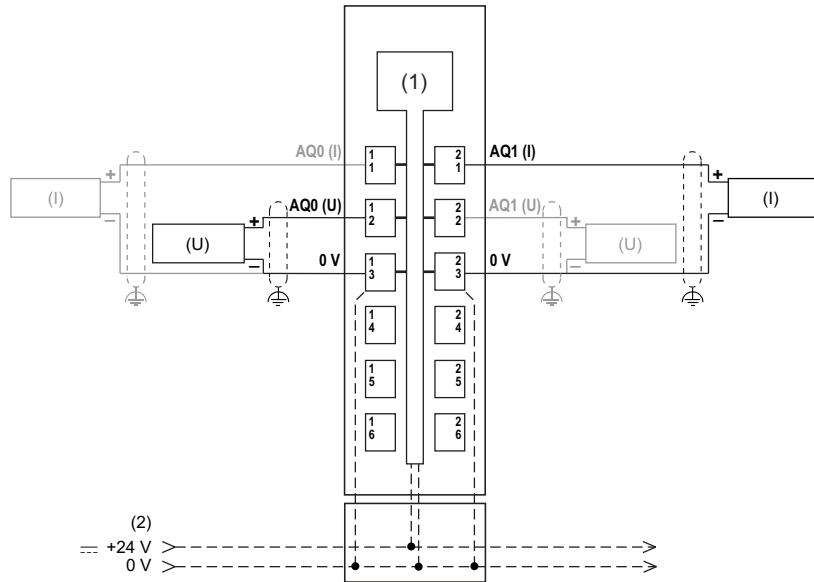

(1): Internal electronics

(2): 24 Vdc I/O power segment integrated into the bus bases

(I): Current

(U): Voltage

Use shielded, properly grounded cables for all analog and high-speed inputs or outputs and communication connections. If you do not use shielded cable for these connections, electromagnetic interference can cause signal degradation. Degraded signals can cause the controller or attached modules and equipment to perform in an unintended manner.

 WARNING

UNINTENDED EQUIPMENT OPERATION

- Use shielded cables wherever specified for inputs, outputs and communication connections.
- Properly ground the cable shields as indicated in the related documentation.
- Route communication and I/O cables separately from power cables.

Failure to follow these instructions can result in death, serious injury, or equipment damage.

 WARNING

UNINTENDED EQUIPMENT OPERATION

Do not connect wires to unused terminals or terminals marked "Not Connected (N.C.)".

Failure to follow these instructions can result in death, serious injury, or equipment damage.

8.4 TM5SAO4H Electronic Module 4AO $\pm 10V/0-20mA$ 16 Bits

What's in this Section?

This section contains the following topics:

Topic	Page
TM5SAO4H Presentation	150
TM5SAO4H Characteristics	152
TM5SAO4H Wiring Diagram	156

TM5SAO4H Presentation

Main Characteristics

The table below describes the main characteristics of the TM5SAO4H electronic module:

Main Characteristics		
Number of output channels	4	
Signal type	Voltage	Current
Output range	-10...+10 Vdc	0...20 mA
Resolution	15 bits + sign	15 bits

Ordering Information

The following figure shows the slice with a TM5SAO4H:

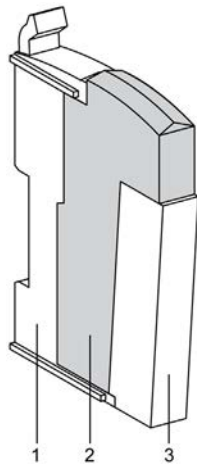

The table below shows the model numbers for the terminal block and bus base associated to TM5SAO4H:

Number	Model Number	Description	Color
1	TM5ACBM11	Bus base	White
	or TM5ACBM15	Bus base with address setting	White
2	TM5ASAO4H	Electronic module	White
3	TM5ACTB12	Terminal block, 12 pins	White

NOTE: For more information, refer to *TM5 bus bases and terminal blocks* (see *Modicon TM5 / TM7 Flexible System, System Planning and Installation Guide*)

Status LEDs

The following figure shows the TM5SAO4H status LEDs:

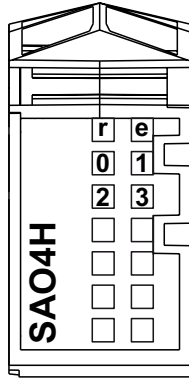

The table below shows the TM5SAO4H status LEDs:

LEDs	Color	Status	Description
r	Green	Off	No power supply
		Single Flash	Reset state
		Flashing	Preoperational state
		On	Normal operation
e	Red	Off	OK or no power supply
		On	Detected error or reset state
0-3	Yellow	Off	Value = 0
		On	Value ≠ 0

TM5SAO4H Characteristics

Introduction

This is the description characteristics for the **TM5SAO4H** electronic module.
See also Environmental Characteristics (*see page 23*).

⚠ DANGER
FIRE HAZARD
Use only the recommended wire sizes for I/O channels and power supplies.
Failure to follow these instructions will result in death or serious injury.

⚠ WARNING
UNINTENDED EQUIPMENT OPERATION
Do not exceed any of the rated values specified in the following tables.
Failure to follow these instructions can result in death, serious injury, or equipment damage.

General Characteristics

The table below describes the general characteristics of the TM5SA04H electronic module:

General Characteristics	
Rated power supply voltage Power supply source	24 Vdc Connected to the 24 Vdc I/O power segment
Power supply range	20.4...28.8 Vdc
24 Vdc I/O segment current draw	63 mA
TM5 Bus 5 Vdc current draw	2 mA
Power dissipation	1.51 W max.
Weight	25 g (0.9 oz)
ID code for firmware update	7077 dec

Output Characteristics

The table below describes the output characteristics of the TM5SA04H electronic module:

Characteristic	Voltage Output	Current Output
Output range	-10...+10 Vdc	0...20 mA
Output impedance	1 k Ω min.	-
Load impedance	+/- 10 mA max	200 Ω min. 500 Ω max.
Sample duration time	50 μ s for all outputs	
Output type	Differential	
Response time for output change	1 ms max.	
Over voltage before output change (Response time)	+/- 15% of the Full scale (20V)	-
Over current before output change (Response time)	-	+/- 10% of the Full scale (20mA)
Output tolerance - maximum deviation at ambient 25° C (77° F)	< 0.04% of the measurement	
Output tolerance - temperature drift	0.01% / °C of the measurement	
Output tolerance - non linearity	< 0.005% of the full scale (20 Vdc)	< 0.005% of the full scale (20 mA)
De-rating *	See note *	
Output tolerance - maximum deviation caused by load change	0.02% from 10 M Ω to 1 k Ω , resistive	0.5% from 1 Ω to 500 Ω , resistive
Digital resolution	15 bits + sign	15 bits
Resolution value	305.176 μ V	610.352 nA
Noise resistance - cable	Shielded cable is necessary	
Isolation between channels	Not isolated	
* Note: These analog electronic modules are subject to operating temperature restrictions between 55 and 60 °C (131 and 140 °F). If the ambient temperature of your installation may exceed 55 °C (131 °F), do not install the TM5SAI•H modules adjacent to other devices capable of dissipating more than 1.15 W. For more information refer to <i>Enclosing the TM5 System</i> (see <i>Modicon TM5 / TM7 Flexible System, System Planning and Installation Guide</i>).		

Characteristic	Voltage Output	Current Output
Isolation between channels and bus	See note ¹ .	
Output protection	Short circuit protection: current limitation is 40 mA	
<p>* Note: These analog electronic modules are subject to operating temperature restrictions between 55 and 60 °C (131 and 140 °F). If the ambient temperature of your installation may exceed 55 °C (131 °F), do not install the TM5SAI•H modules adjacent to other devices capable of dissipating more than 1.15 W. For more information refer to <i>Enclosing the TM5 System</i> (see <i>Modicon TM5 / TM7 Flexible System, System Planning and Installation Guide</i>).</p>		

¹ The isolation of the electronic module is 500 Vac RMS between the electronics power by the TM5 bus and those powered by 24 Vdc I/O power segment connected to the module. In practice, the TM5 electronic module is installed in the bus base, and there is a bridge between the TM5 power bus and the 24 Vdc I/O power segment. The two power circuits reference the same functional ground (FE) through specific components designed to reduce effects of electromagnetic interference. These components are rated at 30 Vdc or 60 Vdc. This effectively reduces isolation of the entire system from the 500 Vac RMS.

De-rating the output load

The analog output modules can be configured as voltage outputs, current outputs, or a mix of voltage and current outputs. In the case of a mixed configuration, you must adjust the following de-rating information.

If only one of the outputs in the mix is configured as a current output, use the mean between the current and voltage curves. If more than one output in the mix is configured as a current output, use the current output de-rating curve. Otherwise, use the appropriate de-rating information as follows:

De-rating the voltage output load in a horizontal installation:

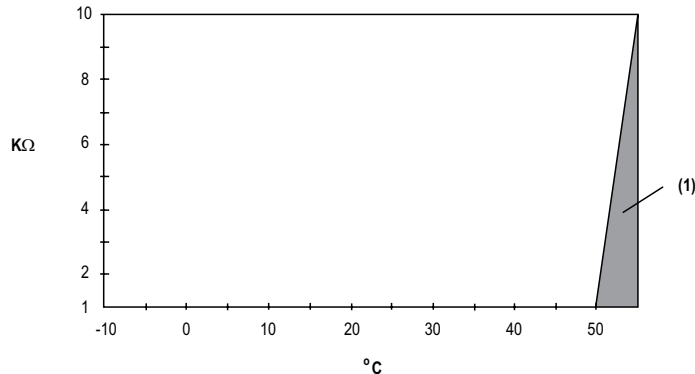

1 Invalid area

De-rating the current output load in a horizontal installation:

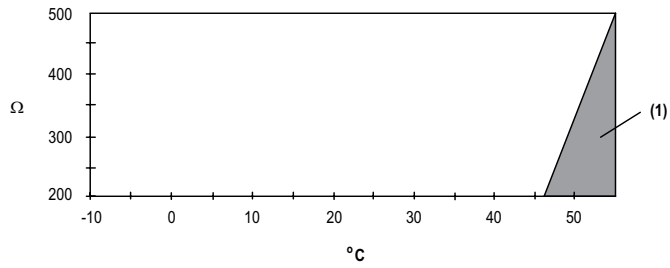

1 Invalid area

De-rating the voltage output load in a vertical installation:

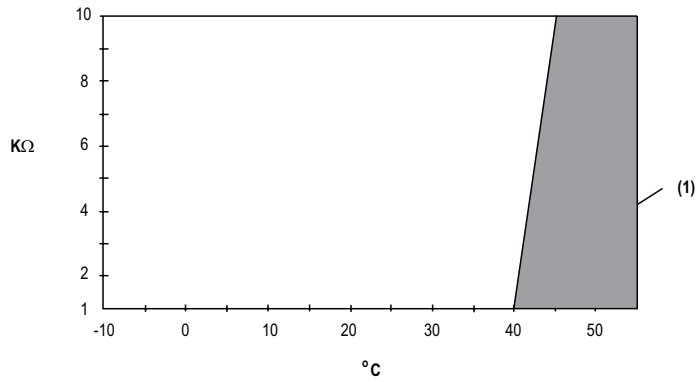

1 Invalid area

De-rating the current output load in a vertical installation:

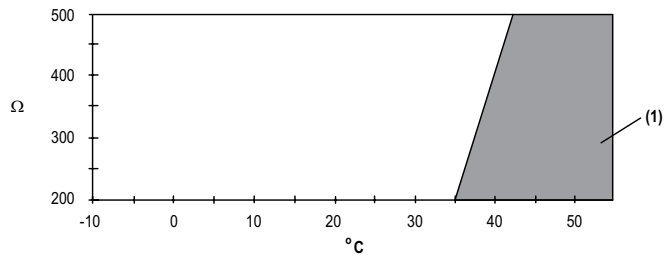

1 Invalid area

TM5SAO4H Wiring Diagram

Wiring Diagram

The following figure shows the wiring diagram for TM5SAO4H:

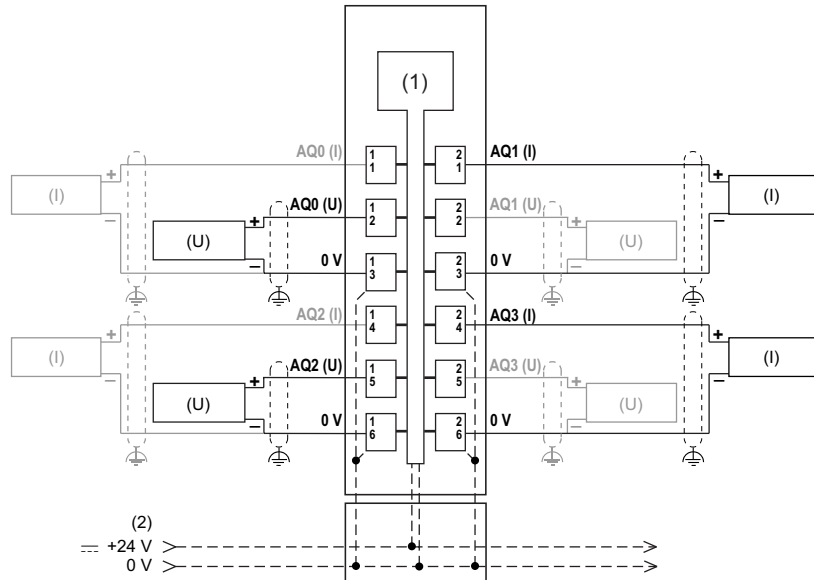

(1): Internal electronics

(2): 24 Vdc I/O power segment integrated into the bus bases

(I): Current

(U): Voltage

Use shielded, properly grounded cables for all analog and high-speed inputs or outputs and communication connections. If you do not use shielded cable for these connections, electromagnetic interference can cause signal degradation. Degraded signals can cause the controller or attached modules and equipment to perform in an unintended manner.

 WARNING

UNINTENDED EQUIPMENT OPERATION

- Use shielded cables wherever specified for inputs, outputs and communication connections.
- Properly ground the cable shields as indicated in the related documentation.
- Route communication and I/O cables separately from power cables.

Failure to follow these instructions can result in death, serious injury, or equipment damage.

 WARNING

UNINTENDED EQUIPMENT OPERATION

Do not connect wires to unused terminals or terminals marked “Not Connected (N.C.)”.

Failure to follow these instructions can result in death, serious injury, or equipment damage.

Glossary

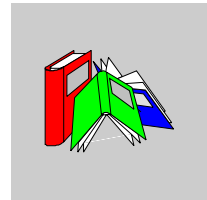

A

analog input

An *analog input* module contains circuits that convert an analog DC input signal to a digital value that can be manipulated by the processor. By implication, the analog input is usually direct. That means a data table value directly reflects the analog signal value.

analog output

An *analog output* module contains circuits that transmit an analog DC signal proportional to a digital value input to the module from the processor. By implication, these analog outputs are usually direct. That means a data table value directly controls the analog signal value.

AWG

The *american wire gauge* standard specifies wire gauges in North America.

B

bus base

A *bus base* is a mounting device that is designed to seat an electronic module on a DIN rail and connect it to the TM5 bus for M258 and LMC058 controllers. Each base bus extends the TM5 data and to the power buses and the 24 Vdc I/O power segment. The electronic modules are added to the TM5 system through their insertion on the base bus. The base bus also supplies the articulation point for the terminal blocks.

C

CAN

The *controller area network* protocol (ISO 11898) for serial bus networks is designed for the interconnection of smart devices (from multiple manufacturers) in smart systems for real-time industrial applications. CAN multimaster systems help ensure high data integrity through the implementation of broadcast messaging and advanced diagnostic mechanisms. Originally developed for use in automobiles, CAN is now used in a variety of industrial automation control environments.

CANopen

CANopen is an open industry-standard communication protocol and device profile specification.

compact I/O module

A *compact I/O module* is an indissociable group of five analog and/or digital I/O electronic modules in a single reference.

configuration

The *configuration* includes the arrangement and interconnection of hardware components within a system and the hardware and software selections that determine the operating characteristics of the system.

controller

A *controller* (or “programmable logic controller,” or “programmable controller”) is used to automate industrial processes.

CPDM

controller power distribution module

CSA

The *canadian standards association* defines and maintains standards for industrial electronic equipment in hazardous environments.

CTS

Clear to send is a data transmission signal and acknowledges the RDS signal from the transmitting station.

D

De-rating

De-rating describes a reduction in an operating specification. For devices in general it is usually a specified reduction in nominal power to facilitate operation at increased ambient conditions like higher temperatures or higher altitudes.

DHCP

The *dynamic host configuration protocol* is an advanced extension of BOOTP. DHCP is a more advanced, but both DHCP and BOOTP are common. (DHCP can handle BOOTP client requests.)

digital I/O

A *digital input or output* has an individual circuit connection at the electronic module that corresponds directly to a data table bit that holds the value of the signal at that I/O circuit. It gives the control logic digital access to I/O values.

DIN

Deutsches Institut für Normung is a German institution that sets engineering and dimensional standards.

E

electronic module

In a programmable controller system, most electronic modules directly interface to the sensors, actuators, and external devices of the machine/process. This electronic module is the component that mounts in a bus base and provides electrical connections between the controller and the field devices. Electronic modules are offered in a variety of signal levels and capacities. (Some electronic modules are not I/O interfaces, including power distribution modules and transmitter/receiver modules.)

EN

EN identifies one of many European standards maintained by CEN (*European Committee for Standardization*), CENELEC (*European Committee for Electrotechnical Standardization*), or ETSI (*European Telecommunications Standards Institute*).

encoder

An *encoder* is a device for length or angular measurement (linear or rotary encoders).

Ethernet

Ethernet is a physical and data link layer technology for LANs, also known as IEE 802.3.

expansion bus

The *expansion bus* is an electronic communication bus between expansion modules and a CPU.

expert I/O

Expert I/Os are dedicated modules or channels for advanced features. These features are generally embedded in the module in order to not use the resources of the PLC Controller and to allow a fast response time, depending of the feature. Regarding the function, it could be considered as a “stand alone” module, because the function is independent of the Controller processing cycle, it just exchanges some information with the Controller CPU.

F

FAST I/O

FAST I/Os are specific I/Os with some electrical features (response time, for example) but the treatment of these channels is done by the Controller CPU.

FE

Functional ground is the point of a system or device that must be grounded to help prevent equipment damage.

FG

frequency generator

firmware

The *firmware* represents the operating system on a controller.

H

hot swapping

Hot swapping is the replacement of a component with a like component while the system remains operational. The replacement component begins to function automatically after it is installed.

HSC

high-speed counter.

I

I/O

input/output

IEC

The *international electrotechnical commission* is a non-profit and non-governmental international standards organization that prepares and publishes international standards for all electrical, electronic, and related technologies.

input filter

An *input filter* is a special function that rejects input noises. It is useful for helping to minimize input noises and chatter in limit switches. All inputs provide a level of input filtering using the hardware. Additional filtering with software is also configurable through the programming or the configuration software.

IP 20

Ingress protection rating according to IEC 60529. IP20 modules are protected against ingress and contact of objects larger than 12.5 mm. The module is not protected against harmful ingress of water.

L

LED

A *light emitting diode* is an indicator that lights up when electricity passes through it.

M

Modbus

The Modbus communication protocol allows communications between many devices connected to the same network.

N

NC

A *normally closed* contact is a contact pair that is closed when the actuator is de-energized (no power is applied) and open when the actuator is energized (power is applied).

network

A network includes interconnected devices that share a common data path and protocol for communications.

P

PCI

A *peripheral component interconnect* is an industry-standard bus for attaching peripherals.

PDM

A *power distribution module* distributes either AC or DC field power to a cluster of I/O modules.

PE

Protective ground is a return line across the bus for fault currents generated at a sensor or actuator device in the control system.

Profibus DP

Profibus Decentralised Peripheral is a linear bus with a centralized access procedure of the Master/Slave type. Only Master stations, also known as active stations, have access rights to the bus. The Slave or passive stations can only respond to prompts. The physical connection is a single shielded twisted pair, but fiber optic interfaces are available to create tree, star, or ring structures. Compared to the ISO model, only layers 1, 2 are implemented, since access from the user interface is made directly to the link layer via simple mapping of variables.

Pt100/Pt1000

Platinum resistance thermometer are characterized by their nominal resistance R_0 at a temperature of 0°C .

- Pt100 ($R_0 = 100 \text{ Ohm}$)
- Pt1000 ($R_0 = 1 \text{ kOhm}$)

PWM

Pulse width modulation is used for regulation processes (e.g. actuators for temperature control) where a pulse signal is modulated in its length. For these kind of signals, transistor outputs are used.

R**RS-232**

RS-232 (also known as EIA RS-232C or V.24) is a standard type of serial communication bus, based on three wires.

RS-485

RS-485 (also known as EIA RS-485) is a standard type of serial communication bus, based on two wires.

RTS

Request to send is a data transmission signal and will be acknowledged by the CTS signal from the destination node.

RxD

receiving data (data transmission signal)

S

SEL-V

A system that follows IEC 61140 guidelines for *safety extra low voltage* is protected in such a way that voltage between any 2 accessible parts (or between 1 accessible part and the PE terminal for Class 1 equipment) does not exceed a specified value under normal conditions or under single-fault conditions.

sink input

A *sink input* is a wiring arrangement in which the device provides current to the input electronic module. A sink input is referenced to 0 Vdc.

SL

serial line

source output

A *source output* is a wiring arrangement in which the output electronic module provides current to the device. A source output is referenced to +24 Vdc.

T

terminal block

The *terminal block* is the component that mounts in an electronic module and provides electrical connections between the controller and the field devices.

TxD

TxD represents a transmit signal.

U

UL

Underwriters laboratories, US organization for product testing and safety certification.

Index

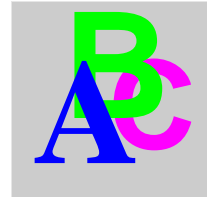

E

- Electronic modules
 - documentation references, 26
 - installation, 26
- environmental characteristics, 23

G

- General characteristics
 - TM5SAI2H, 61
 - TM5SAI2L, 45
 - TM5SAI2PH, 79
 - TM5SAI2TH, 98
 - TM5SAI4H, 69
 - TM5SAI4L, 52
 - TM5SAI4PH, 87
 - TM5SAI6TH, 107
 - TM5SAO2H, 145
 - TM5SAO2L, 129
 - TM5SAO4H, 152
 - TM5SAO4L, 136
 - TM5SEAISG, 116

H

- hot swapping, 27

I

- installation
 - installation requirements, 16

P

- Presentation
 - TM5SAI2H, 59
 - TM5SAI2L, 43
 - TM5SAI2PH, 77
 - TM5SAI2TH, 95
 - TM5SAI4H, 67
 - TM5SAI4L, 50
 - TM5SAI4PH, 85
 - TM5SAI6TH, 104
 - TM5SAO2H, 143
 - TM5SAO2L, 127
 - TM5SAO4H, 150
 - TM5SAO4L, 134
 - TM5SEAISG, 114

T

- TM5 analog
 - TM5SAI2H, 58
 - TM5SAI2L, 42
 - TM5SAI2PH, 76
 - TM5SAI2TH, 94
 - TM5SAI4H, 66
 - TM5SAI4L, 49
 - TM5SAI4PH, 84
 - TM5SAI6TH, 103
 - TM5SAO2H, 142
 - TM5SAO2L, 126
 - TM5SAO4H, 149
 - TM5SAO4L, 133
 - TM5SEAISG, 113

TM5SAI2H, 58
TM5SAI2L, 42
TM5SAI2PH, 76
TM5SAI2TH, 94
TM5SAI4H, 66
TM5SAI4L, 49
TM5SAI4PH, 84
TM5SAI6TH, 103
TM5SAO2H, 142
TM5SAO2L, 126
TM5SAO4H, 149
TM5SAO4L, 133
TM5SEAISG, 113

W

Wiring Diagram

TM5SAI2H, 63
TM5SAI2L, 47
TM5SAI2PH, 81
TM5SAI2TH, 100
TM5SAI4H, 72
TM5SAI4L, 54
TM5SAI4PH, 89
TM5SAI6TH, 109
TM5SAO2H, 147
TM5SAO2L, 131
TM5SAO4H, 156
TM5SAO4L, 140
TM5SEAISG, 119
wiring rules, 19